

CARROZZERIA - VERSIONE ALTA

M32



	R1 METAL	SILVER	INOX LUX	GOLD
GR.2	417-588-000	445-892-000	417-605-000	445-893-000
GR.3	446-608-000	446-570-000	446-612-000	446-571-000
GR.4	447-608-000	447-572-000	447-630-000	447-573-000

R35-3 ← M32 CLASSIC
R35-4 ← M32 DOSATRON

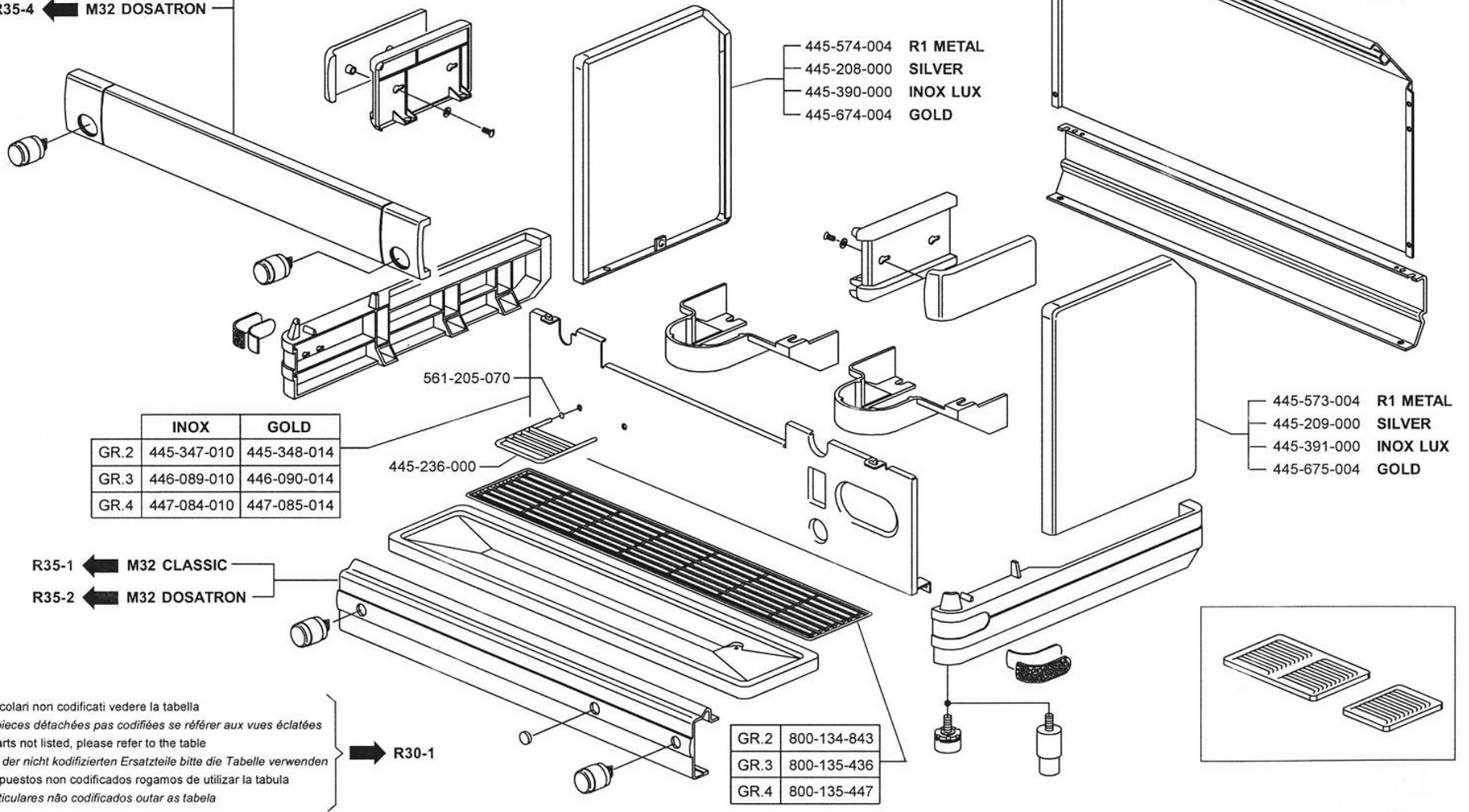

445-574-004	R1 METAL
445-208-000	SILVER
445-390-000	INOX LUX
445-674-004	GOLD

445-573-004	R1 METAL
445-209-000	SILVER
445-391-000	INOX LUX
445-675-004	GOLD

	INOX	GOLD
GR.2	445-347-010	445-348-014
GR.3	446-089-010	446-090-014
GR.4	447-084-010	447-085-014

R35-1 ← M32 CLASSIC
R35-2 ← M32 DOSATRON

GR.2	800-134-843
GR.3	800-135-436
GR.4	800-135-447

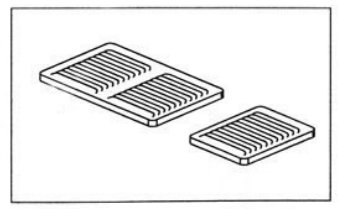

Per i particolari non codificati vedere la tabella
 Pour les pieces détachées pas codifiées se référer aux vues éclatées
 For the parts not listed, please refer to the table
 Bezüglich der nicht kodifizierten Ersatzteile bitte die Tabelle verwenden
 Por los repuestos non codificados rogamos de utilizar la tabula
 Pelos particulares não codificados outar as tabela

→ R30-1

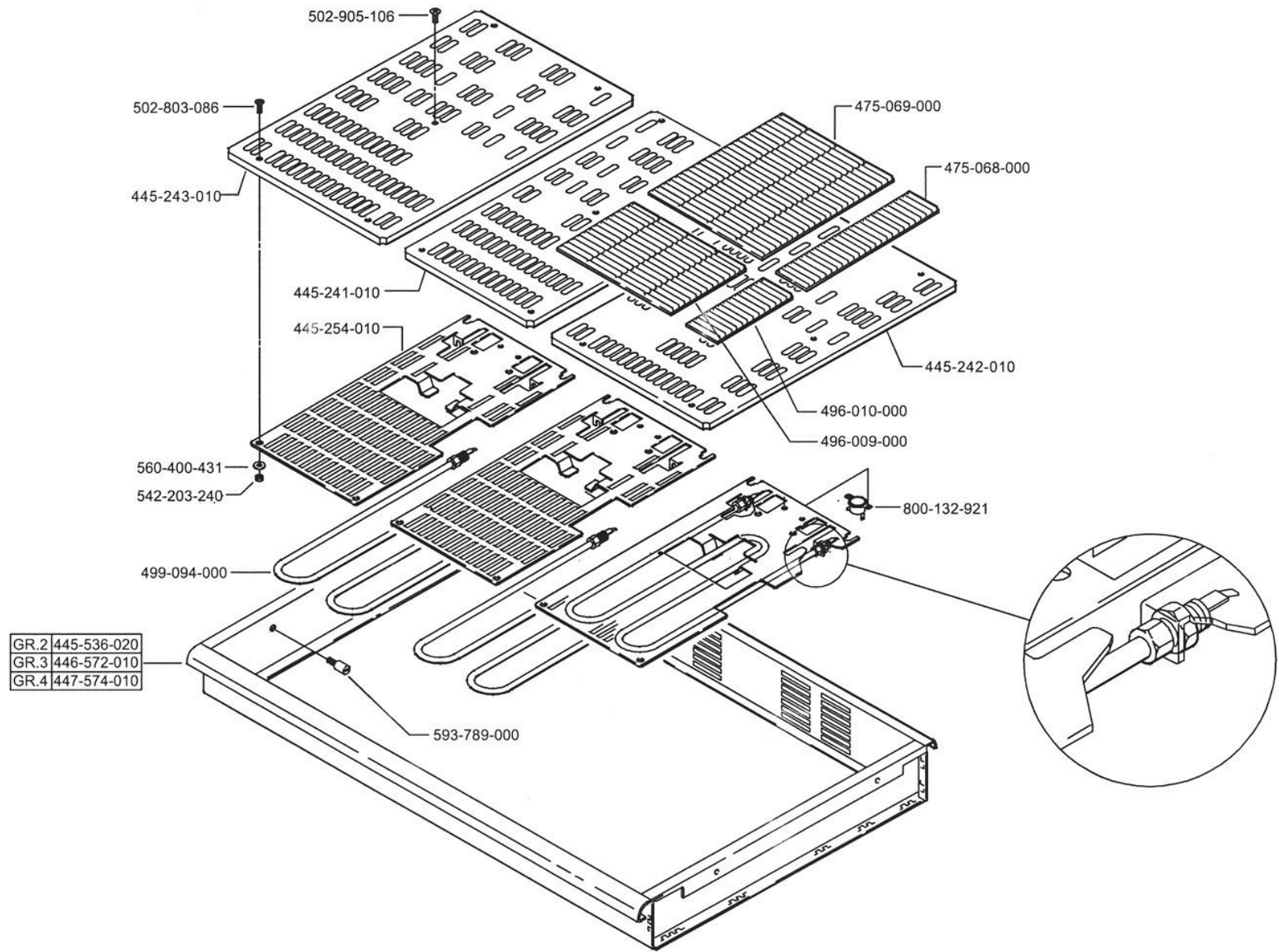

ALIMENTAZIONE GRUPPI

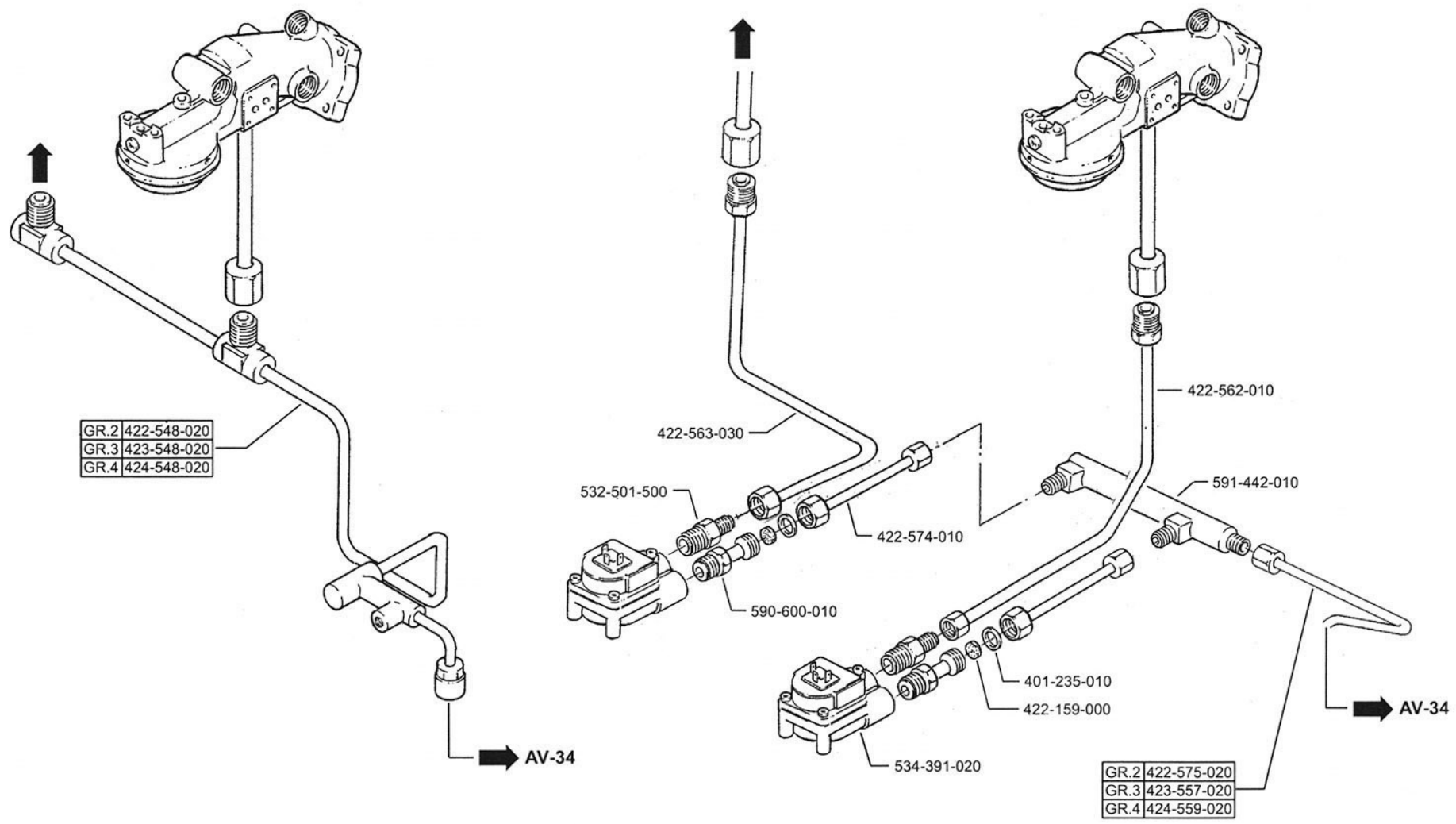
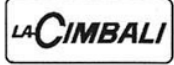

ALIMENTAZIONE GRUPPI

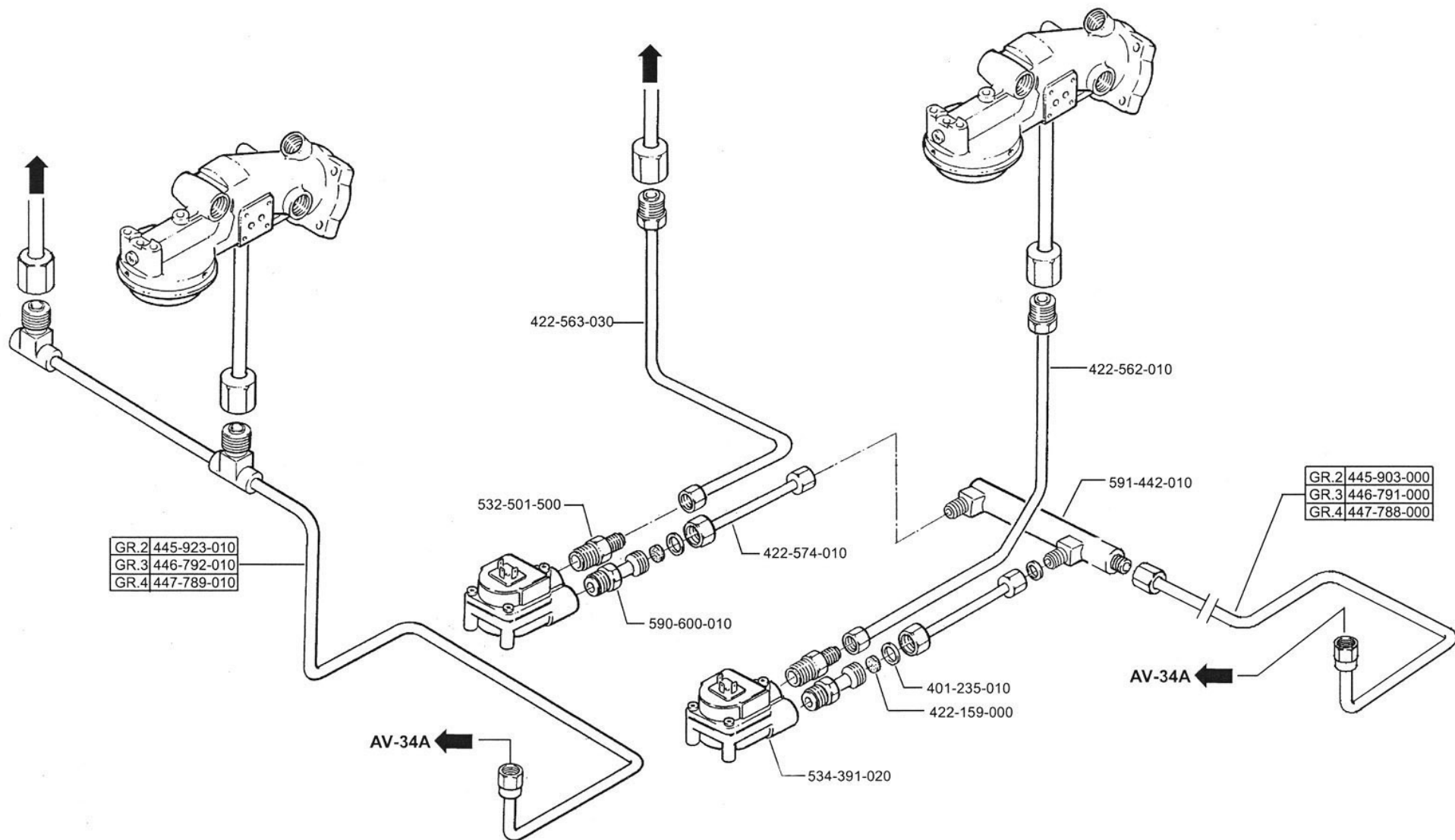

GRUPPO TERMORISERVA TR-TRD

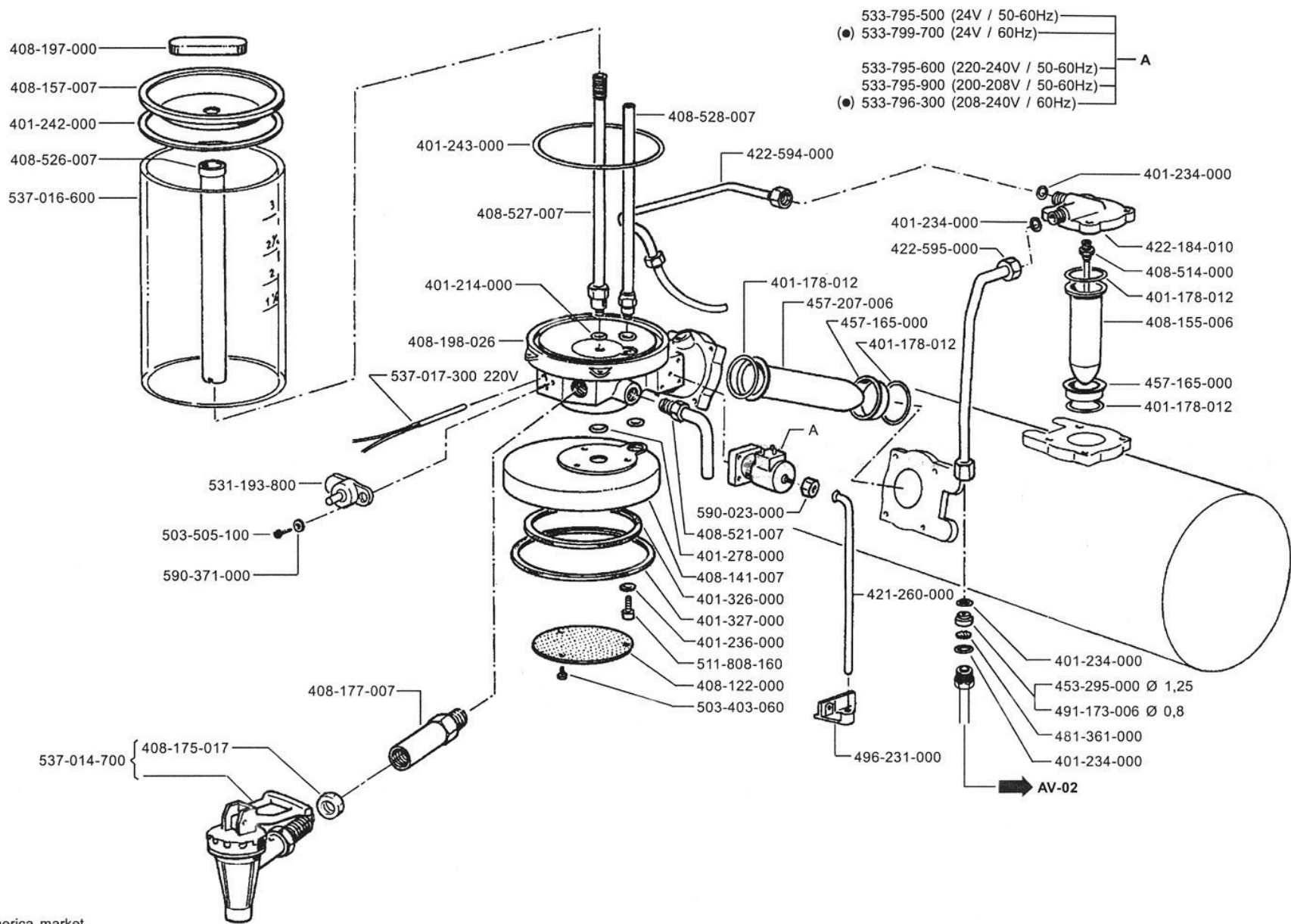

(●) Only for North-America market

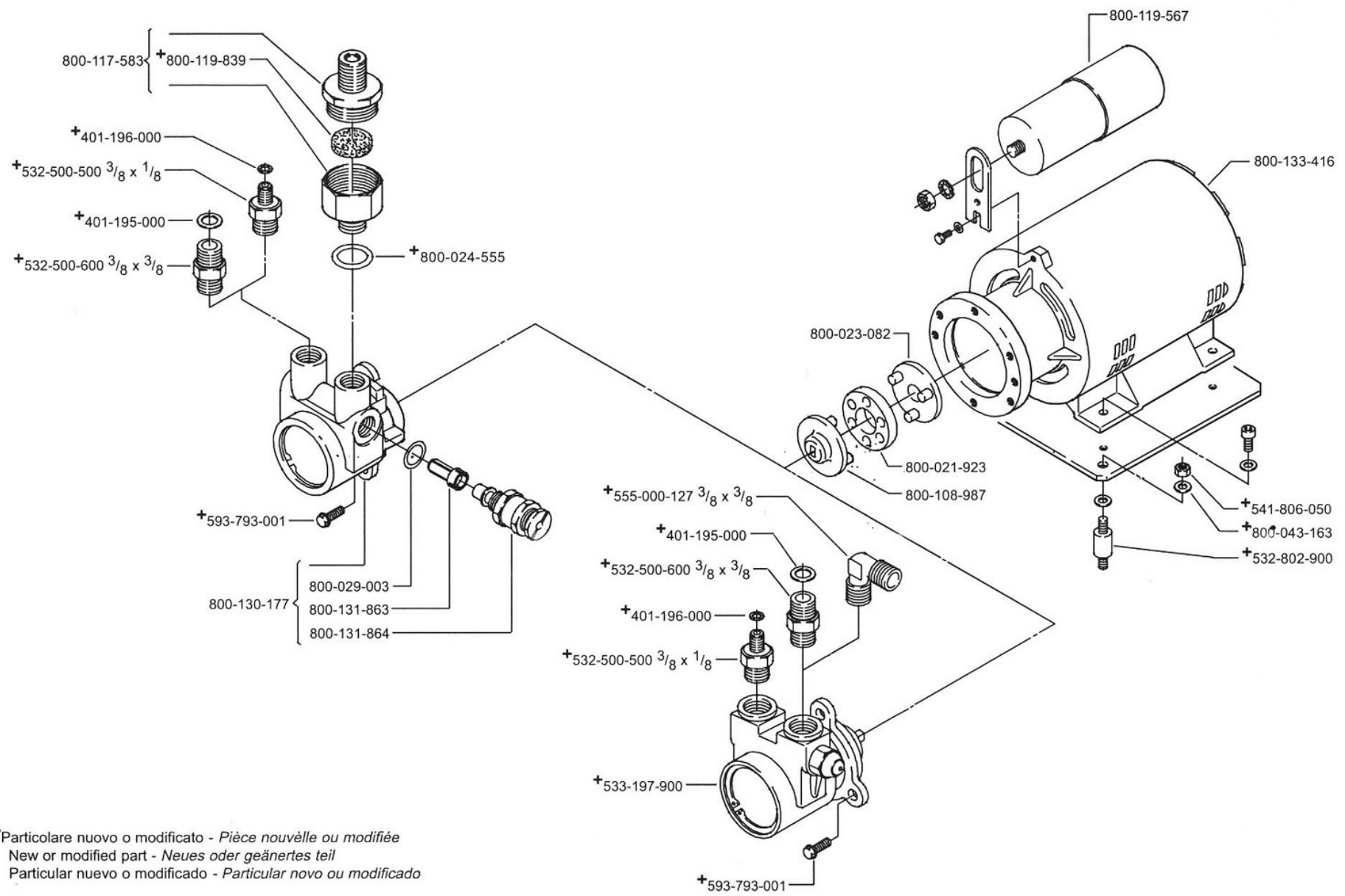

ELETTROPOMPA VOLUMETRICA



+Particolare nuovo o modificato - Pièce nouvelle ou modifiée
 New or modified part - Neues oder geändertes teil
 Particular nuevo o modificado - Particular novo ou modificado

ELETTROPOMPA VOLUMETRICA

(●) Only for North-America market

A			B			
			200-240 V / 50-60 Hz	208-240 V / 50-60 Hz	110-120 V / 50-60 Hz	110-120 V / 60 Hz
CO 1505 BF		533-197-300	530-295-400	530-295-400 (●)	530-295-600	530-295-600 (●)
CO 1305 BF		533-197-100	530-295-400	530-295-400 (●)	530-295-600	530-295-600 (●)
CO5 1309 BF		533-196-900	530-296-900	530-295-200 (●)		

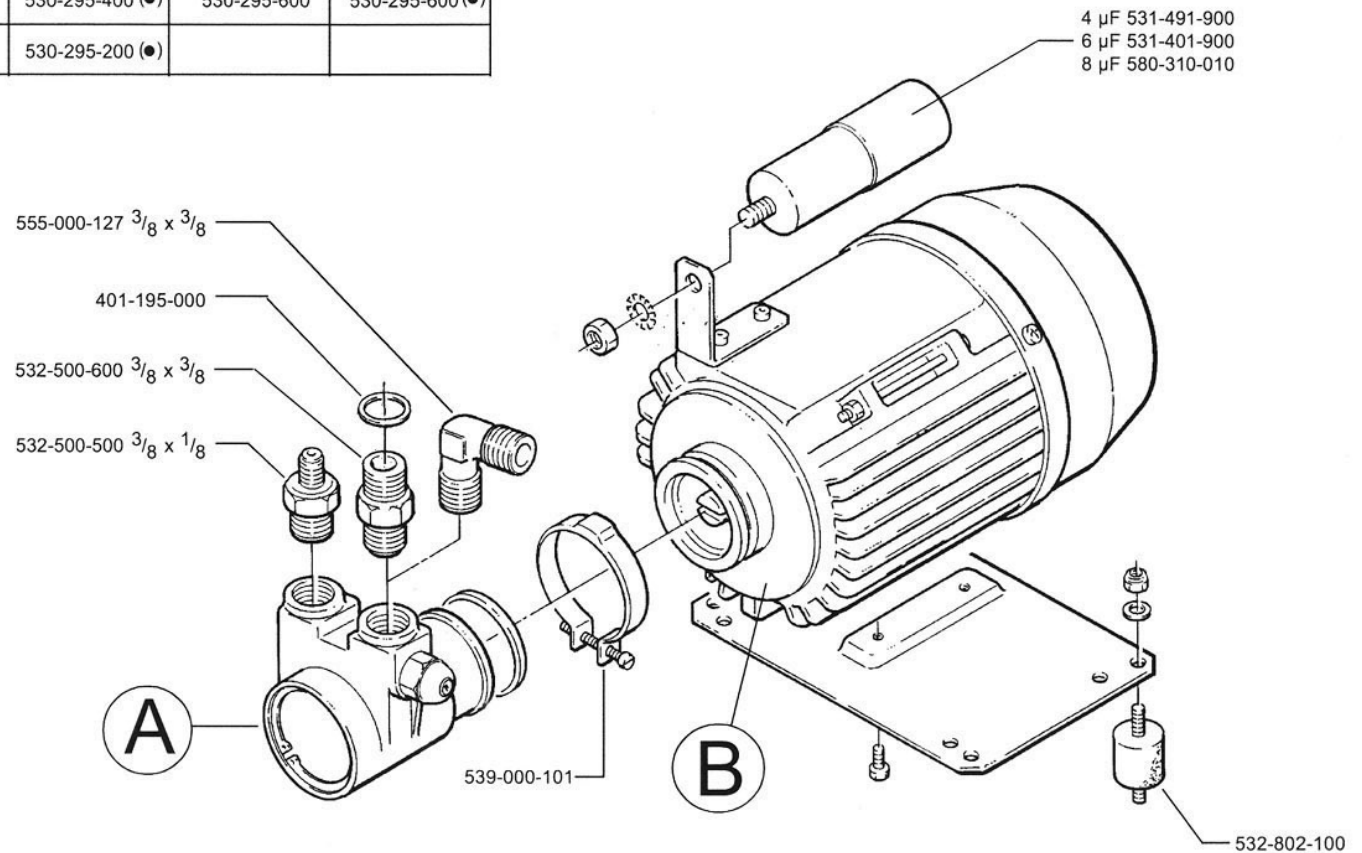

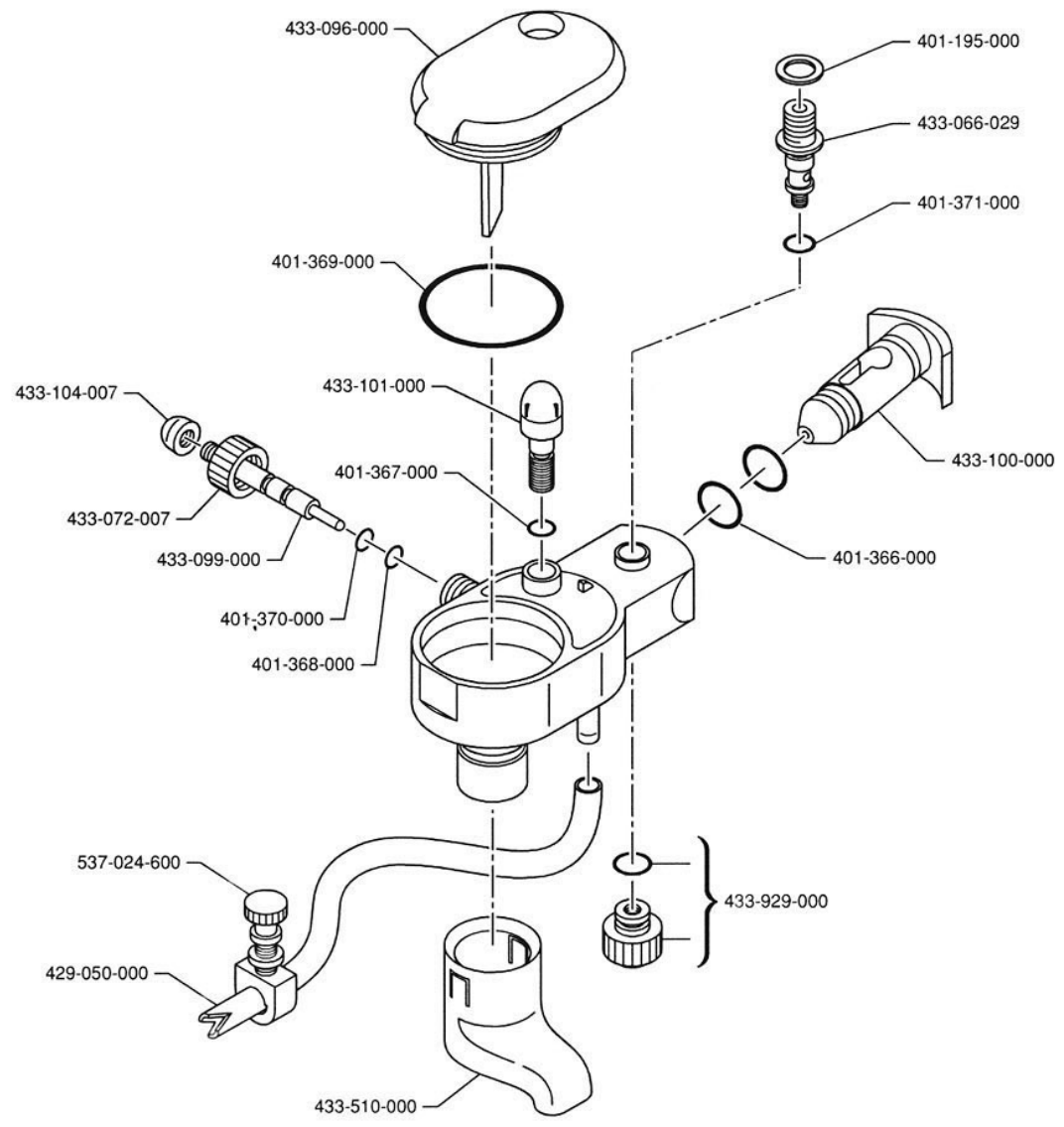

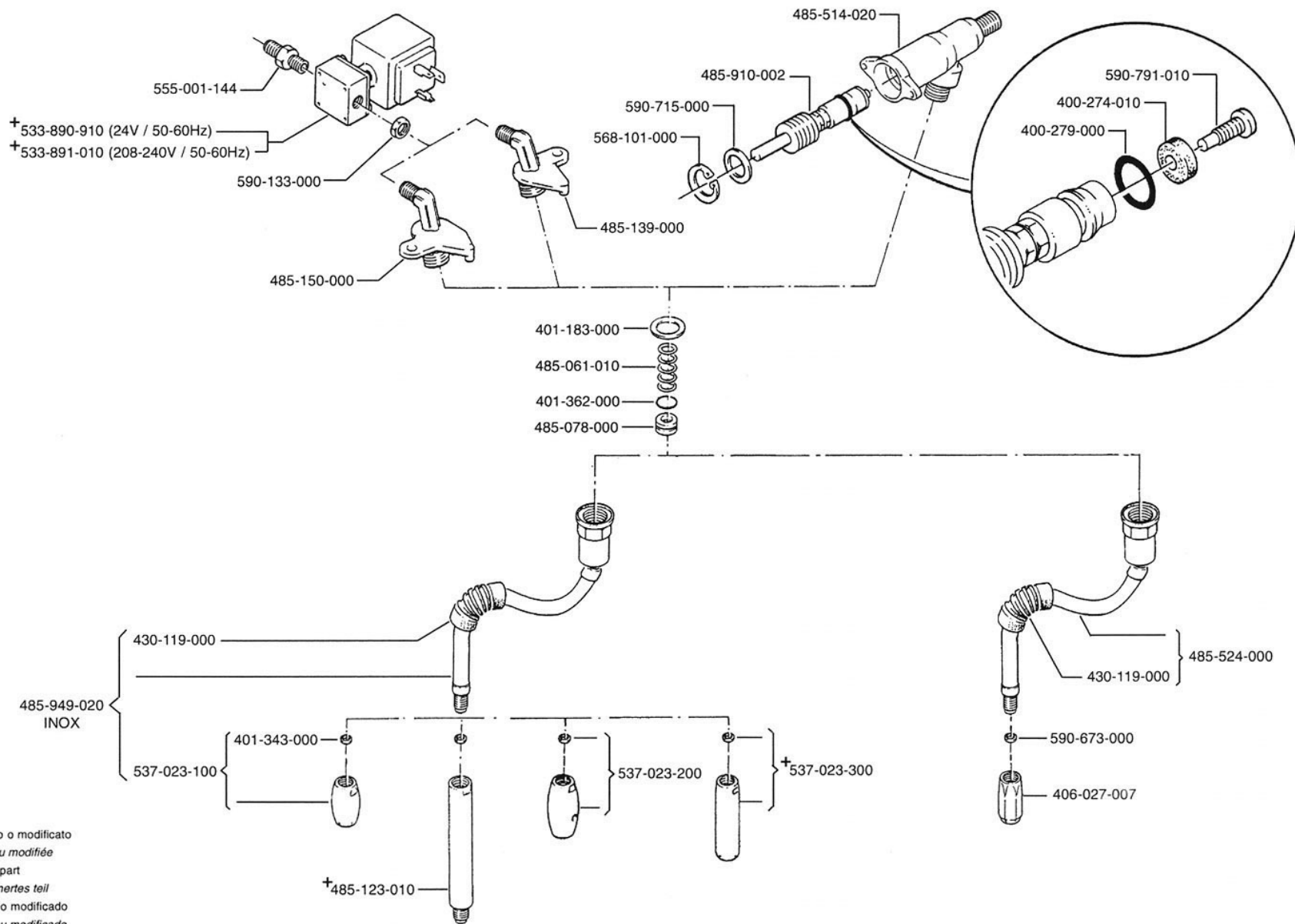

† Particolare nuovo o modificato
 Pièce nouvelle ou modifiée
 New or modified part
 Neues oder geändertes Teil
 Particular nuevo o modificado
 Particular novo ou modificado

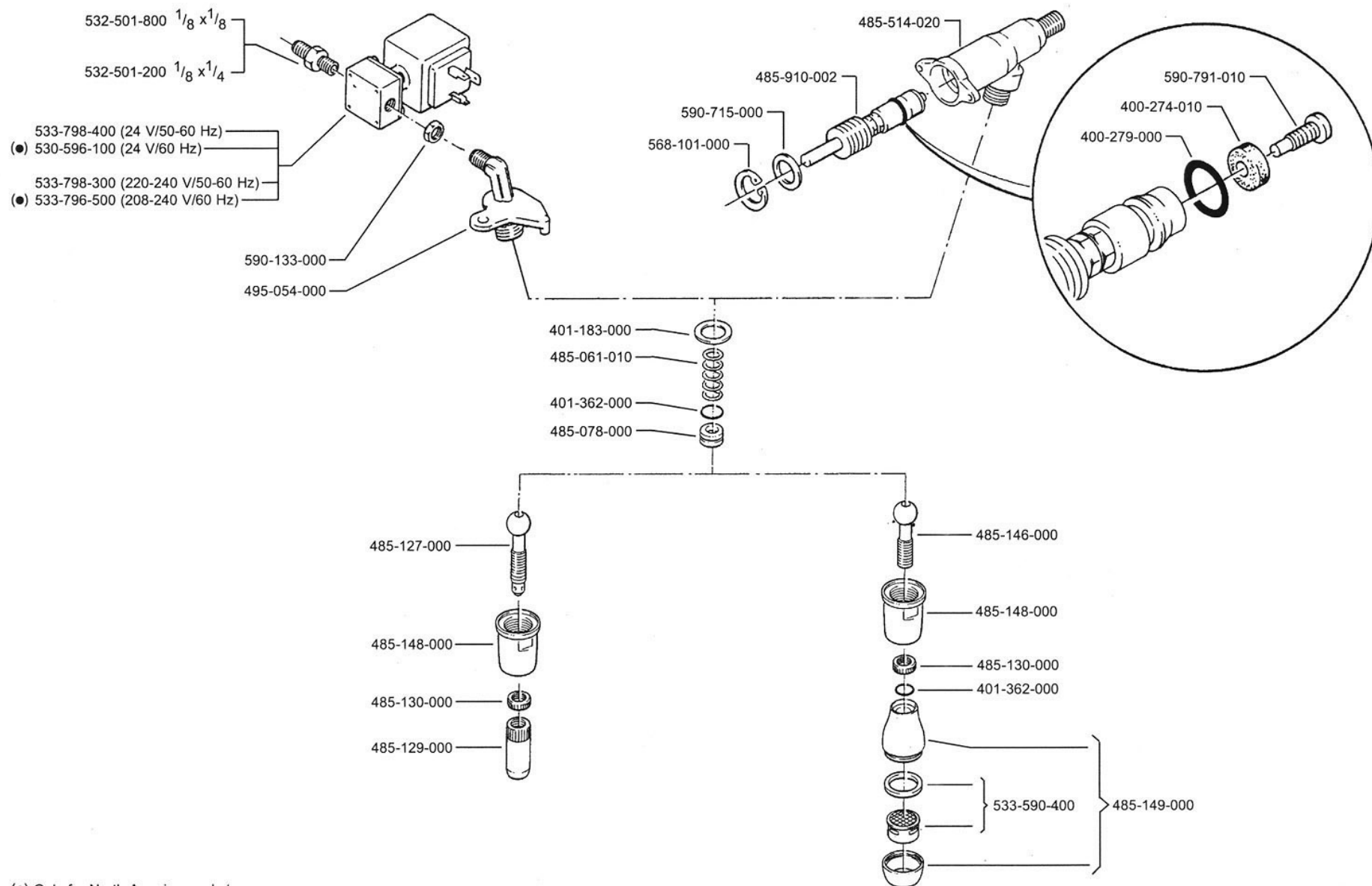

● Only for North-America market

IMPIANTO RISCALDAMENTO A GAS

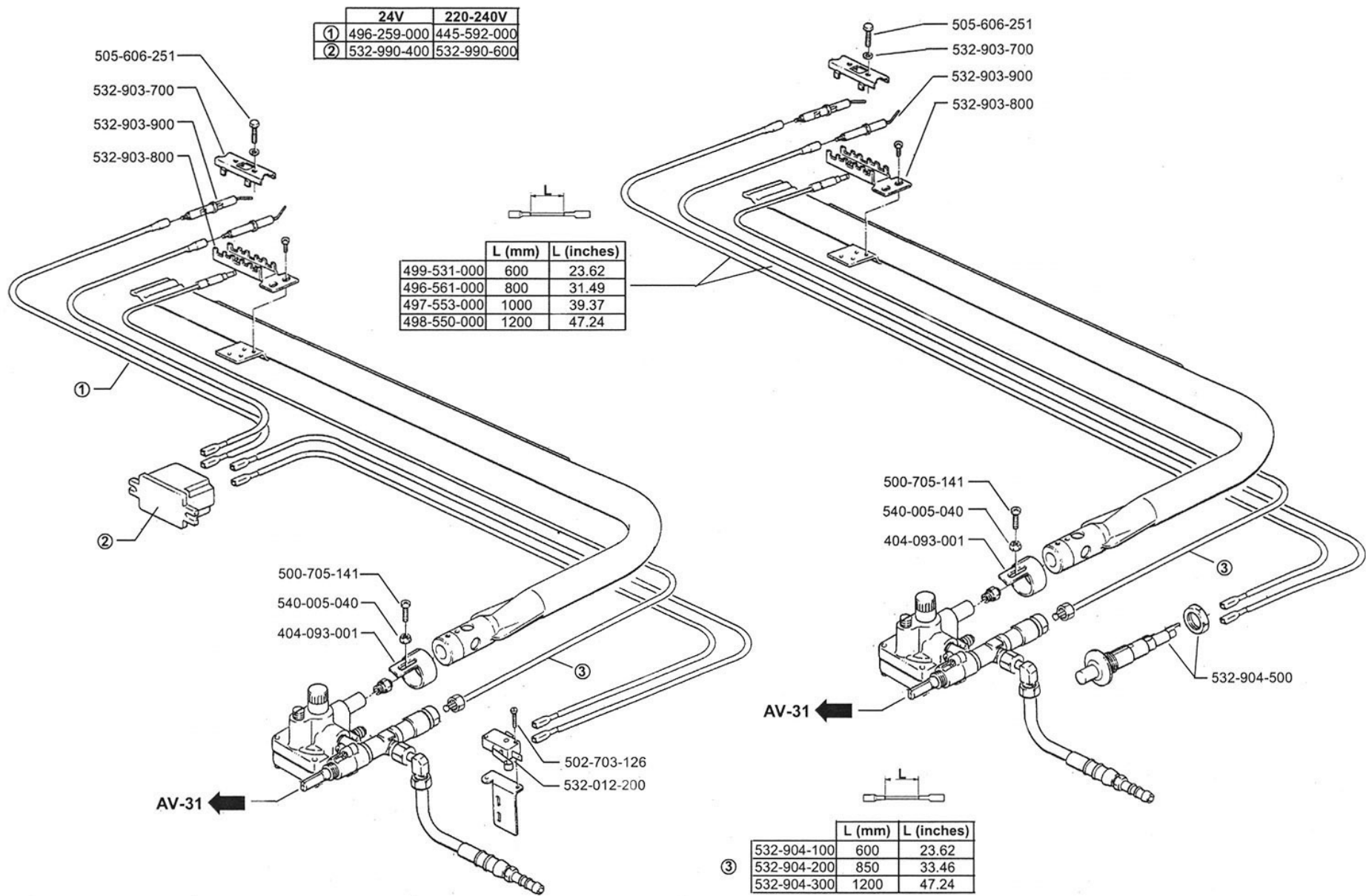

IMPIANTO RISCALDAMENTO A GAS

▲ Solo para el mercado Español

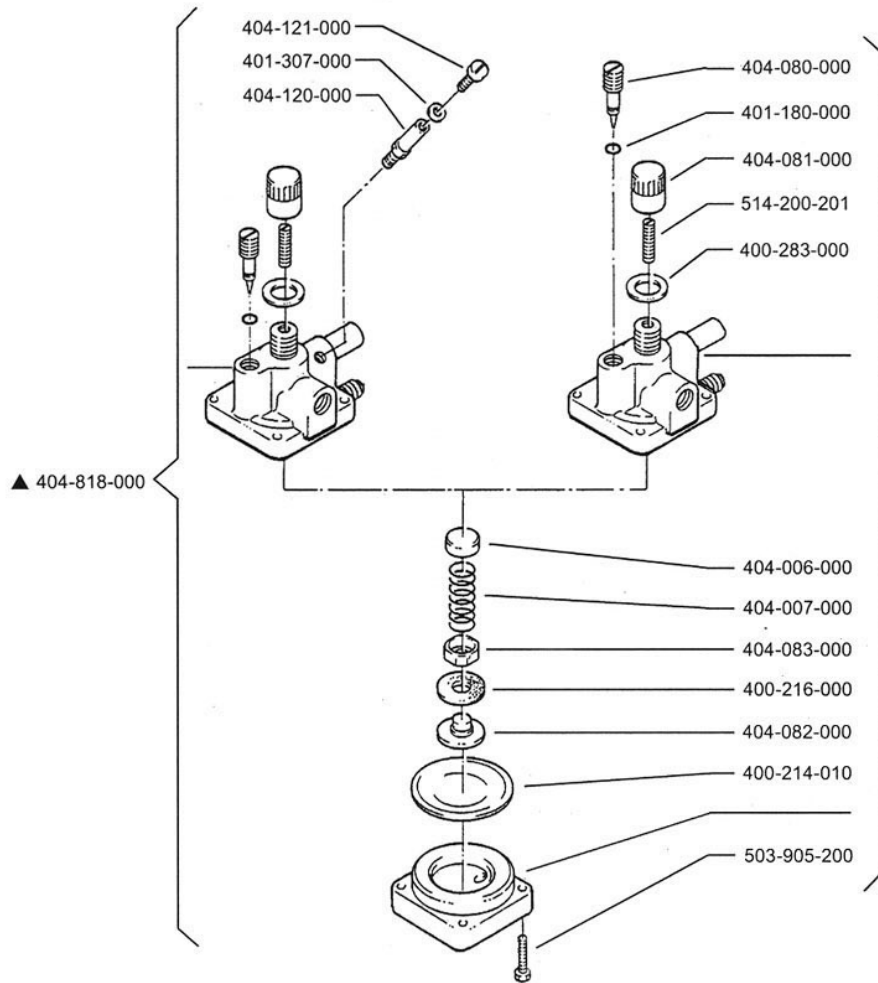

50	532-901-300
70	532-901-400
80	532-901-500
90	532-904-600
100	532-901-600
120	532-901-800
140	532-901-900
160	532-904-700
190	532-904-800
220	532-902-100

404-930-002

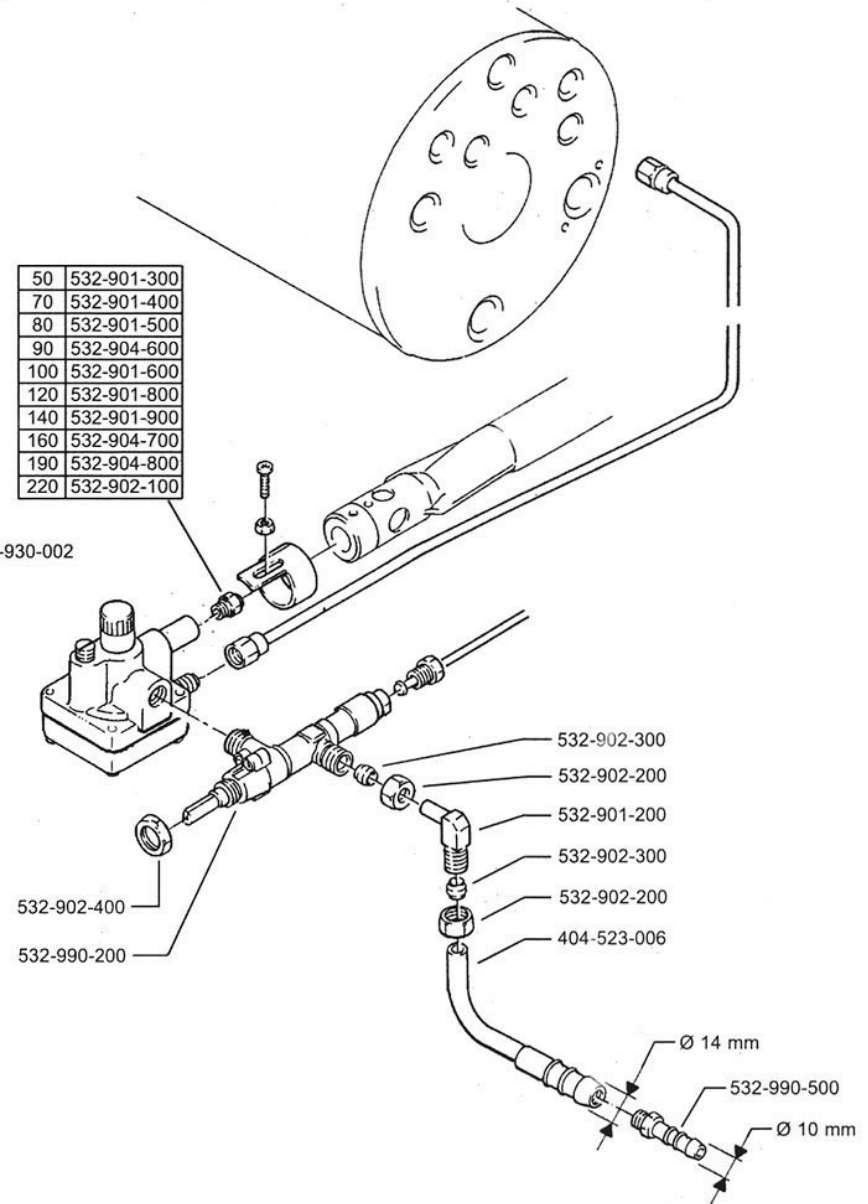

EQUIPAGGIAMENTO CALDAIA

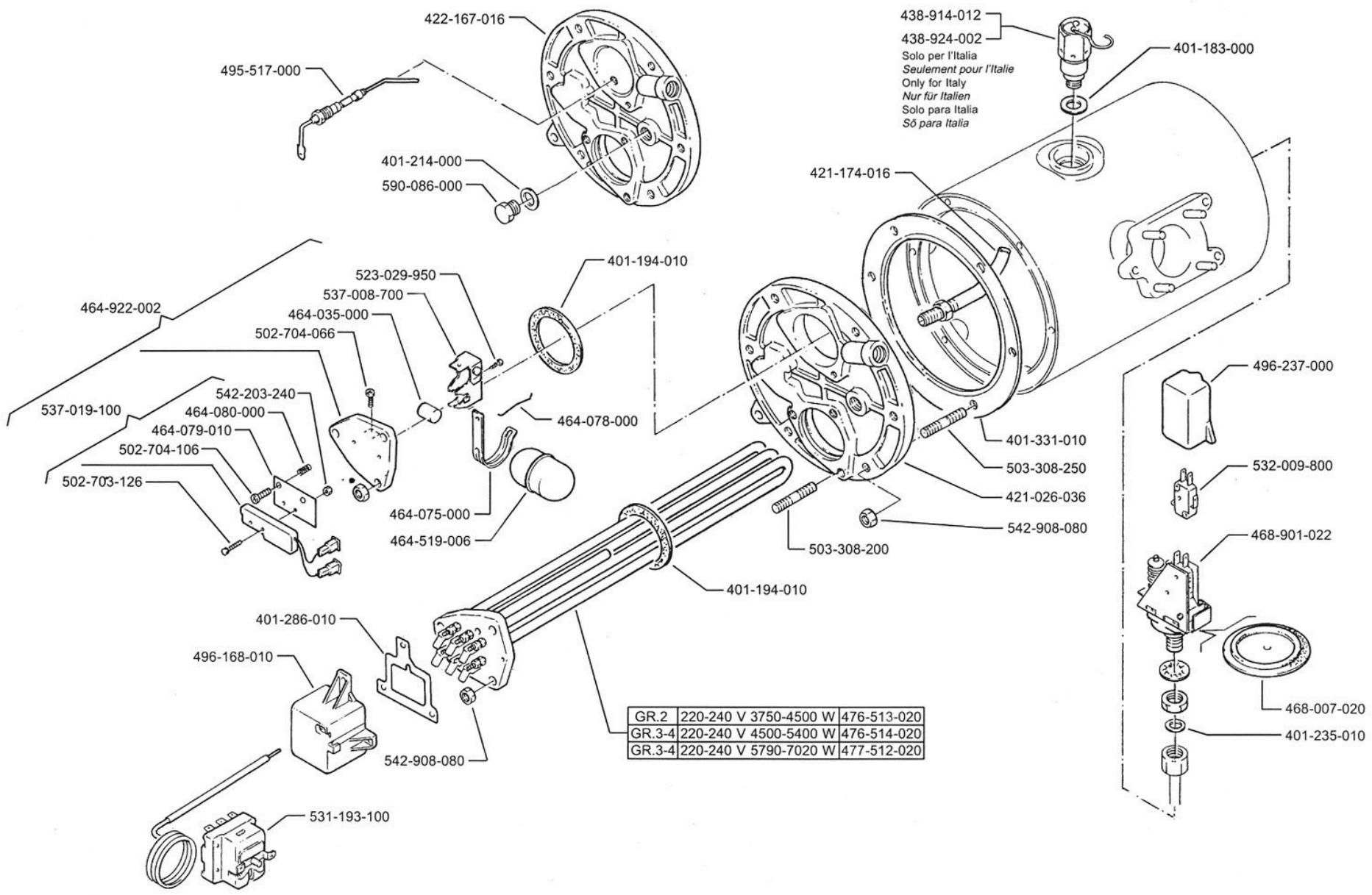
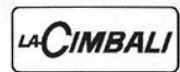

LIVELLO CALDAIA - Economizzatore

(●) Only for North-America market

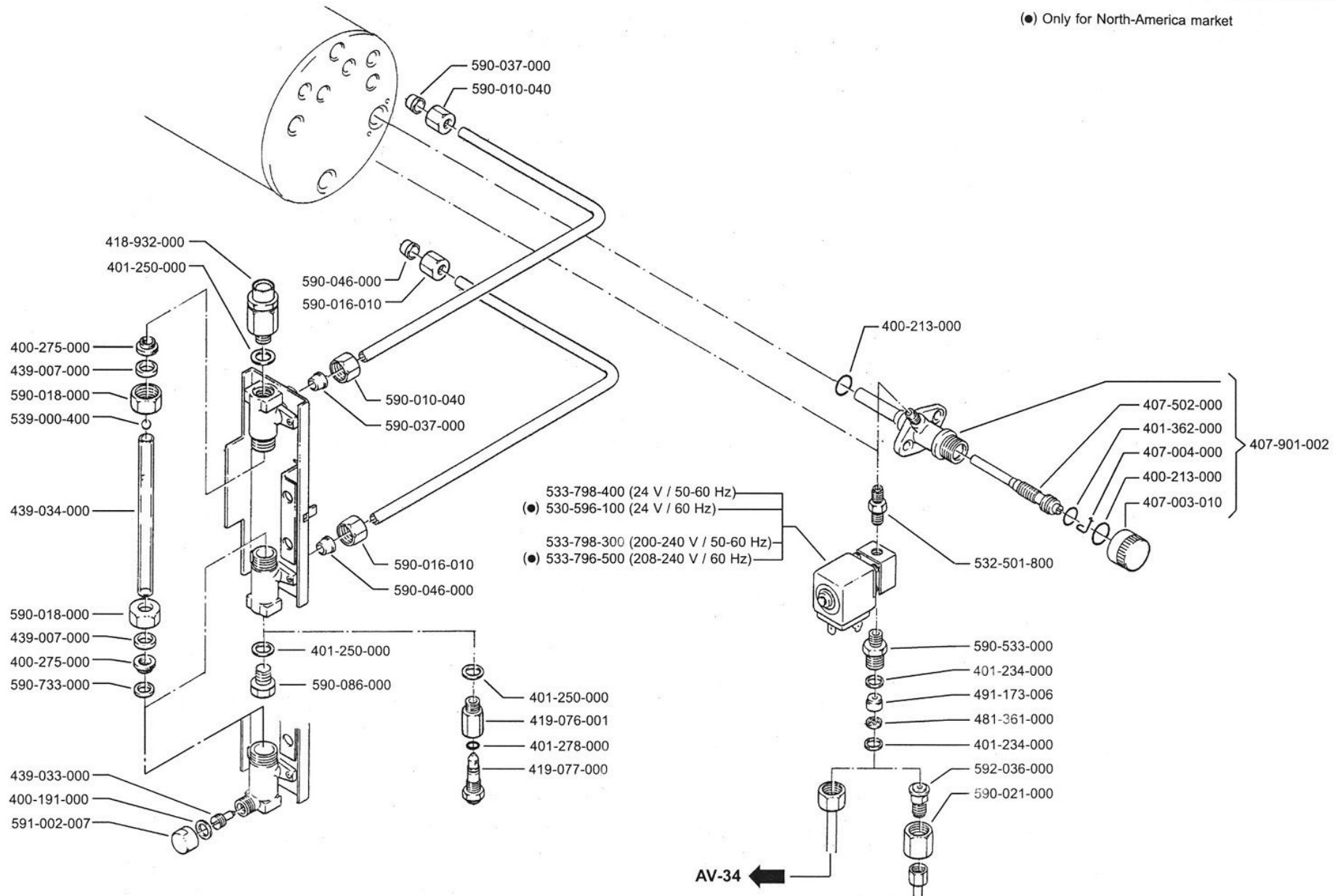

LIVELLO CALDAIA - Economizzatore

(●) Only for North-America market

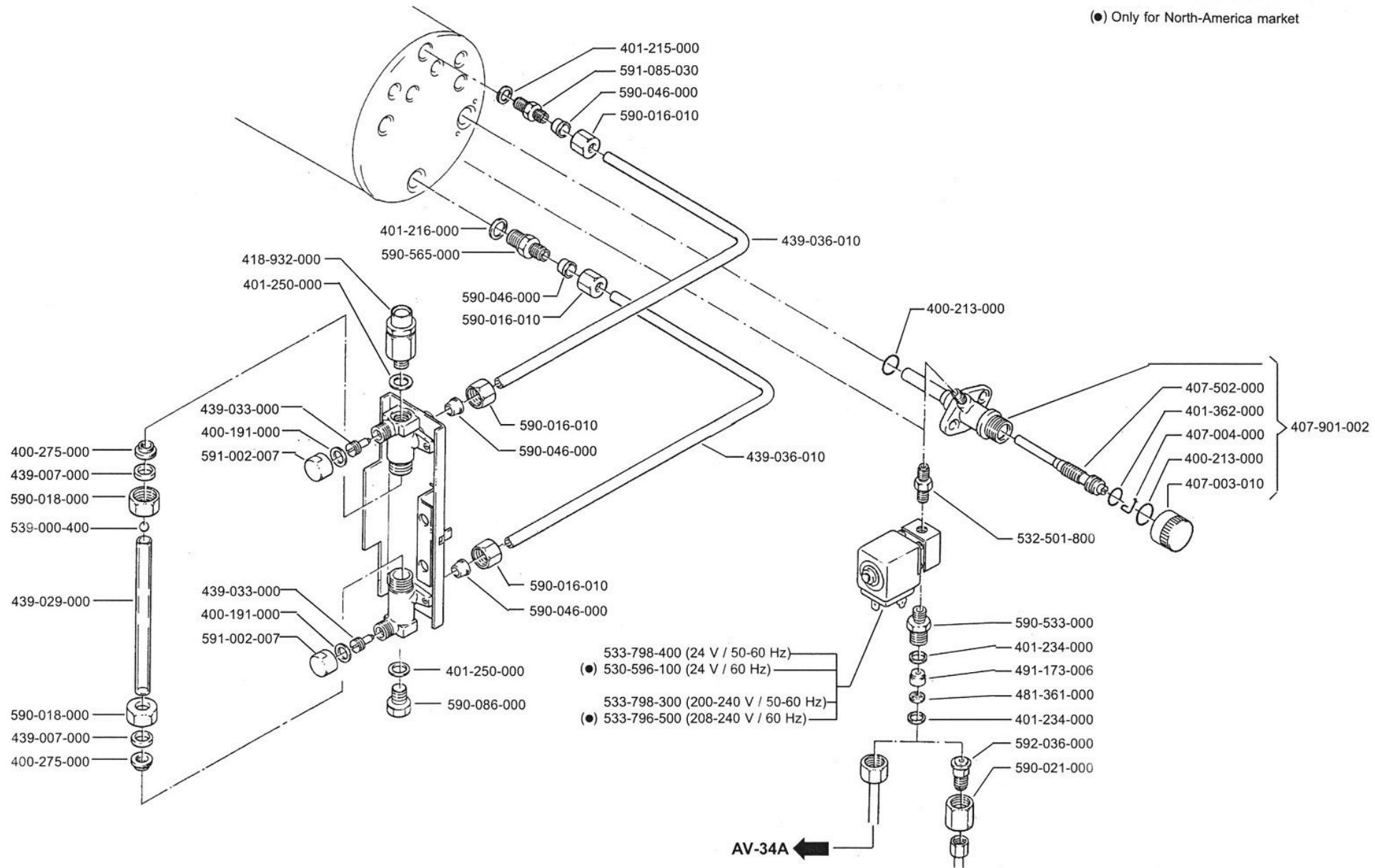

RUBINETTO DI ALIMENTAZIONE

(●) Only for North-America market

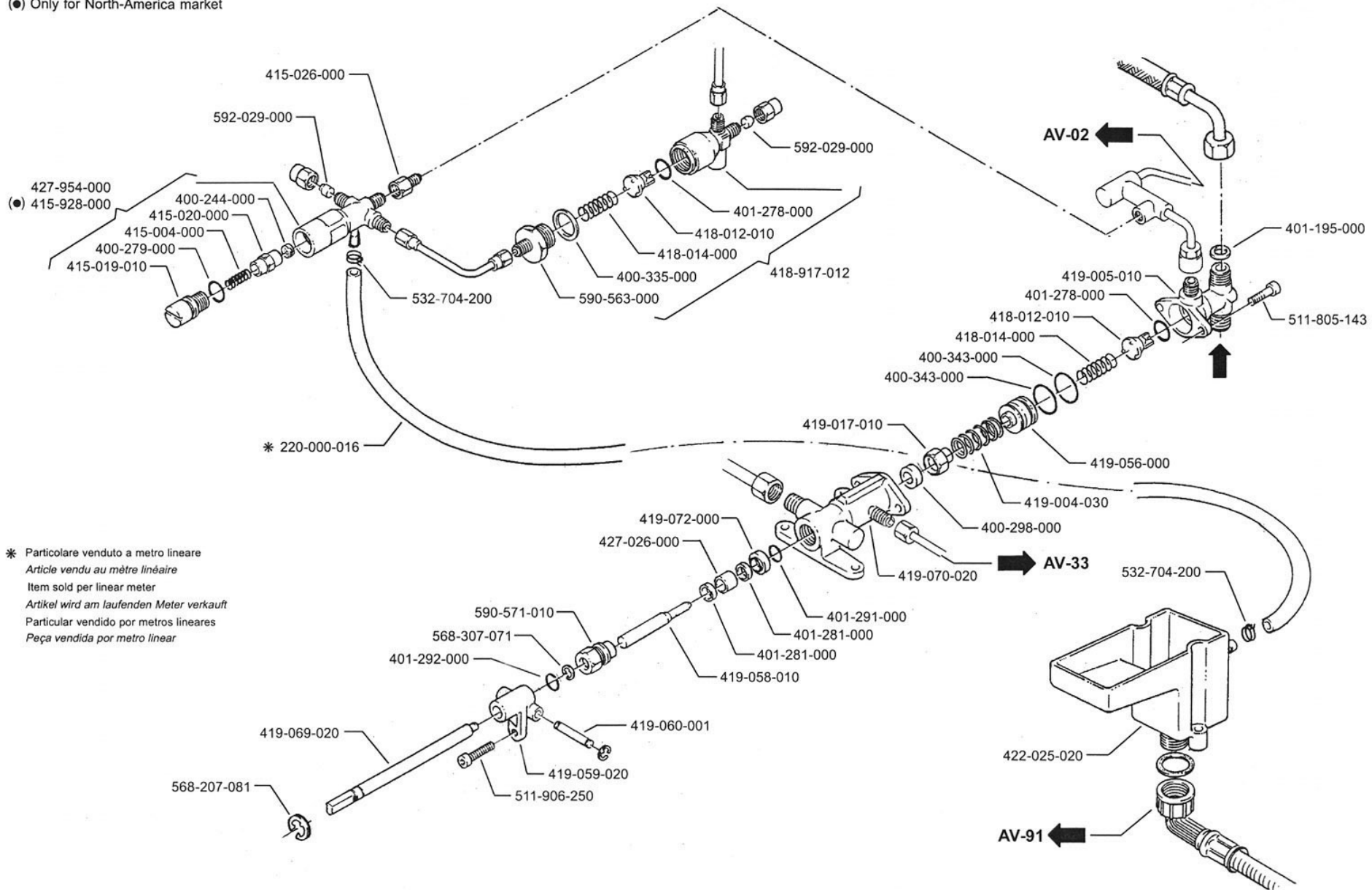

* Particolare venduto a metro lineare
Article vendu au mètre linéaire
Item sold per linear meter
Artikel wird am laufenden Meter verkauft
Particular vendido por metros lineares
Peça vendida por metro linear

RUBINETTO DI ALIMENTAZIONE

(●) Only for North-America market

* Particolare venduto a metro lineare
 Article vendu au mètre linéaire
 Item sold per linear meter
 Artikel wird am laufenden Meter verkauft
 Particular vendido por metros lineares
 Peça vendida por metro linear

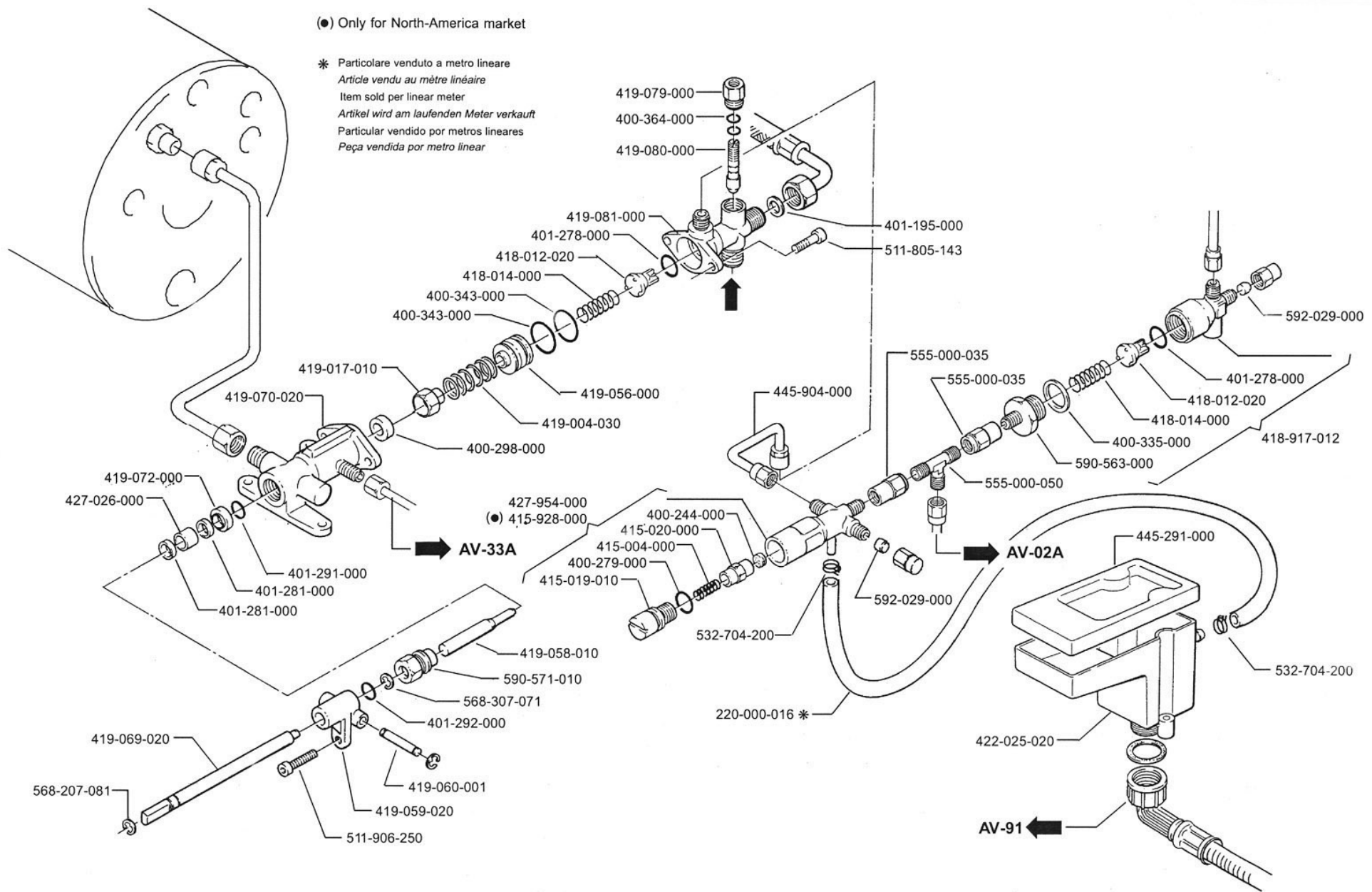

E.D.S. ELECTRONIC DRIVING SYSTEM

(●) Only for North-America market

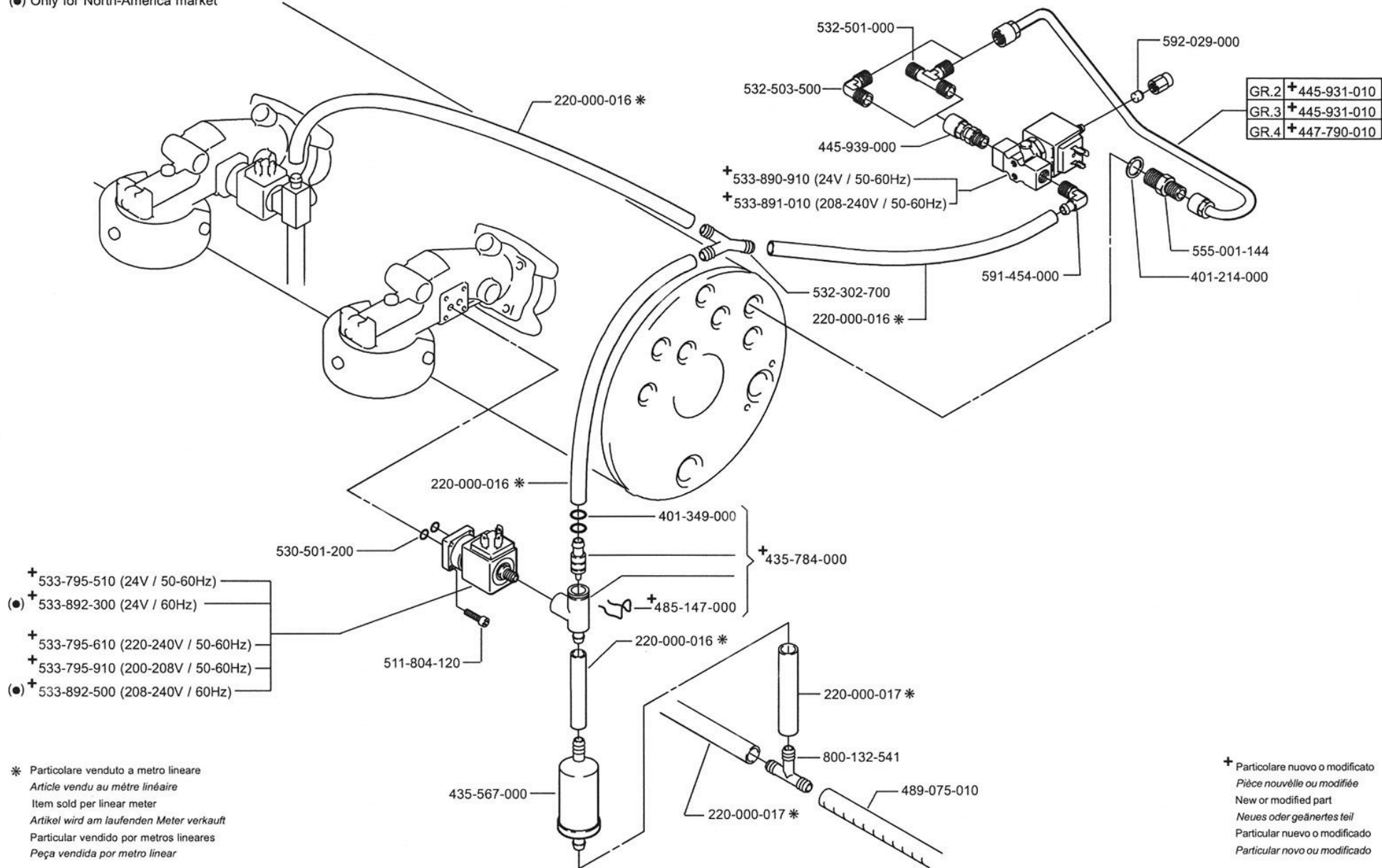

* Particolare venduto a metro lineare
 Article vendu au mètre linéaire
 Item sold per linear meter
 Artikel wird am laufenden Meter verkauft
 Particular vendido por metros lineares
 Peça vendida por metro linear

+ Particolare nuovo o modificato
 Pièce nouvelle ou modifiée
 New or modified part
 Neues oder geändertes teil
 Particular nuevo o modificado
 Particular novo ou modificado

PORTAFILTRI E FILTRI

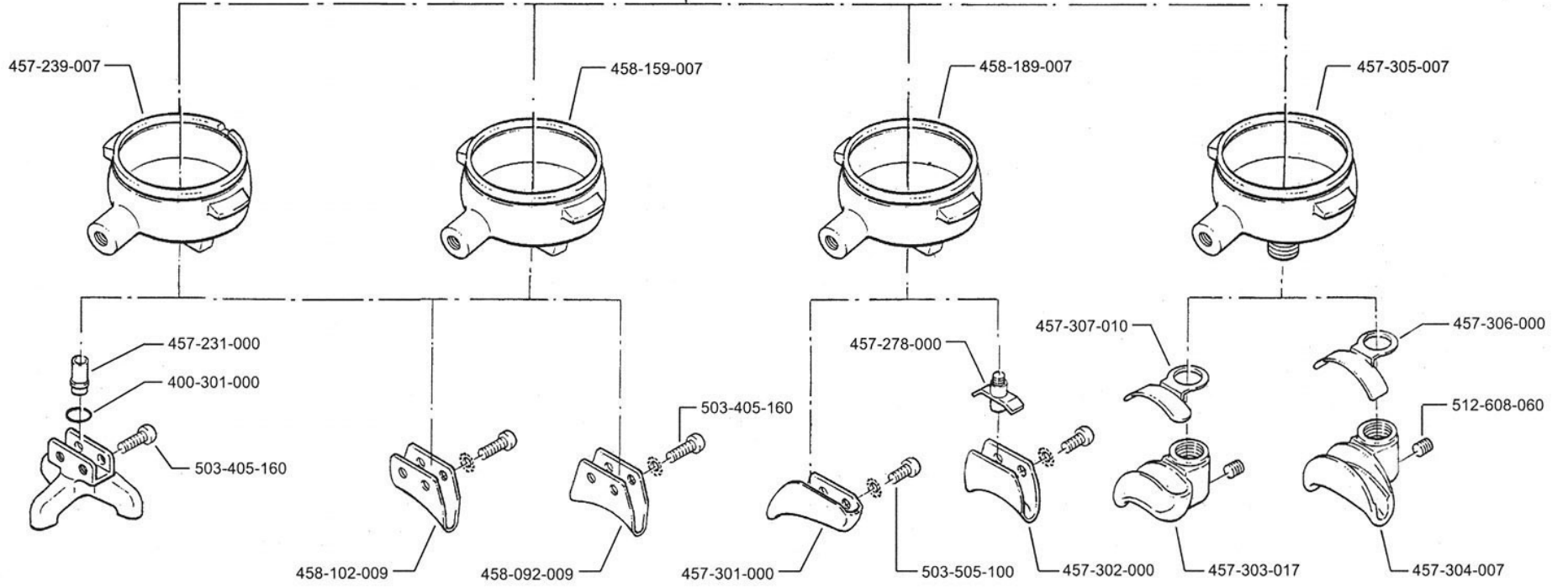
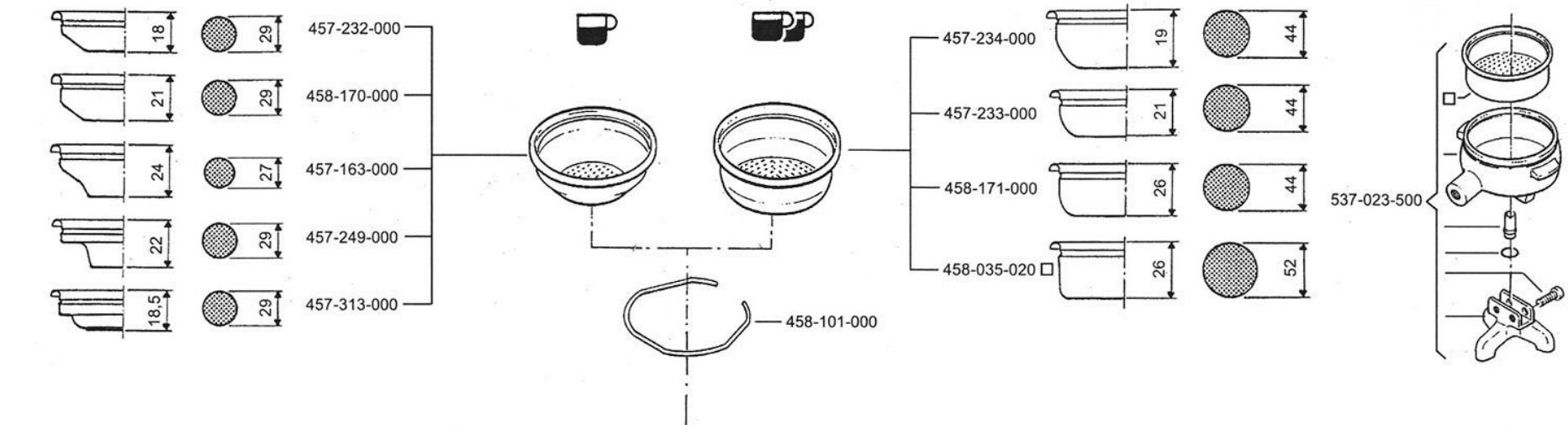

PORTAFILTRO TR-TRD

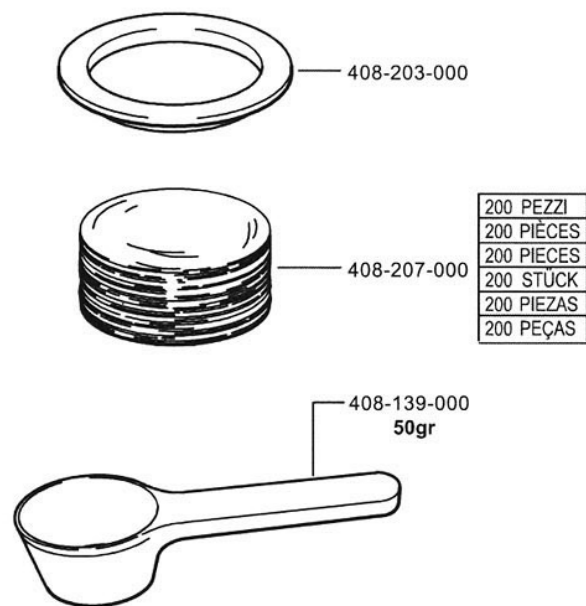
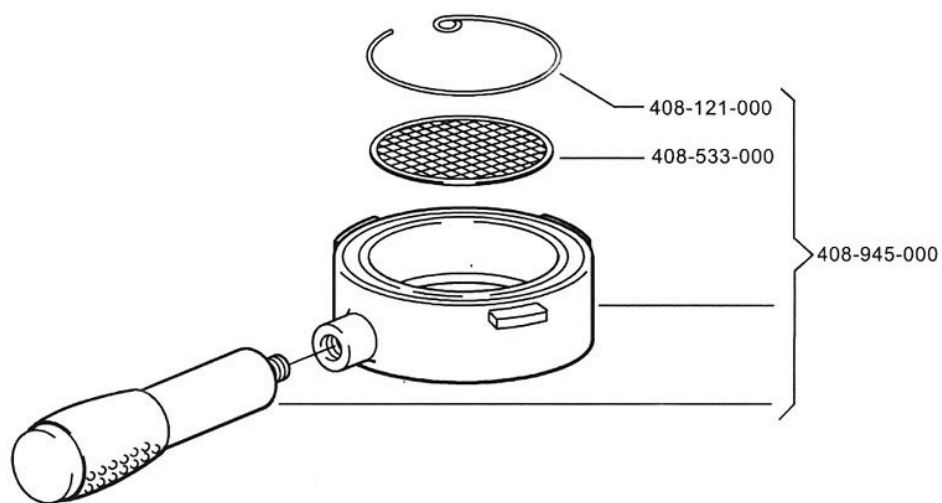

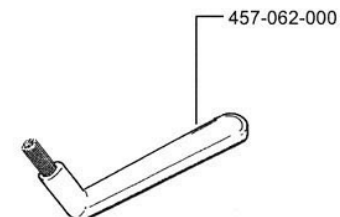
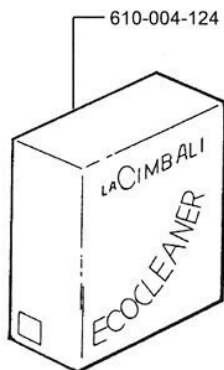
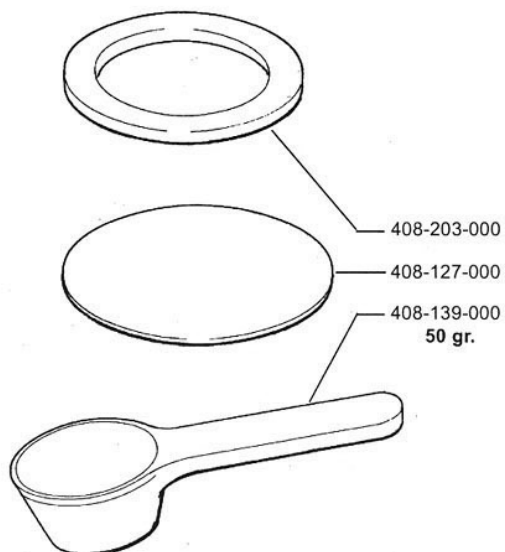
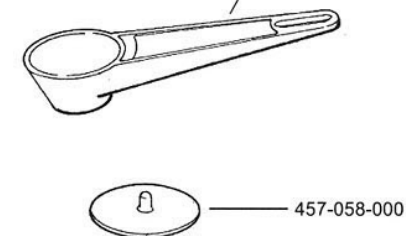
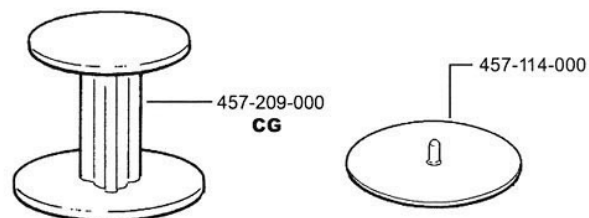
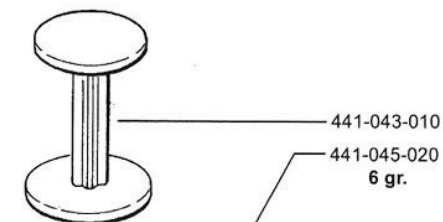
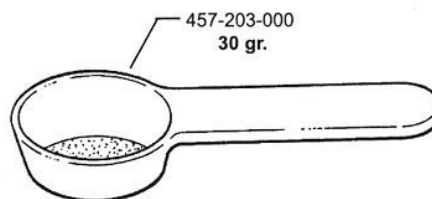
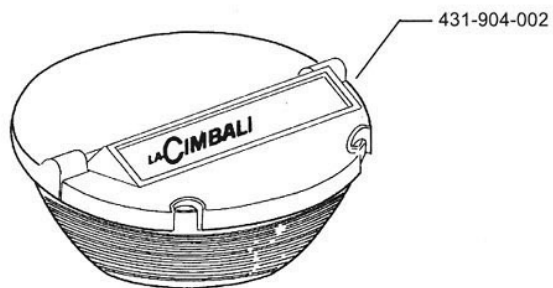

TUBI E RACCORDI

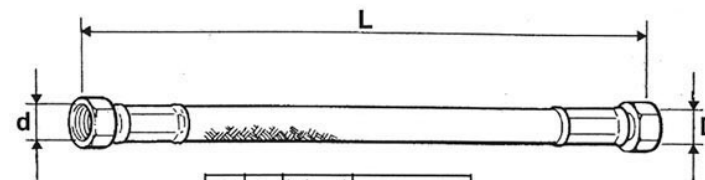
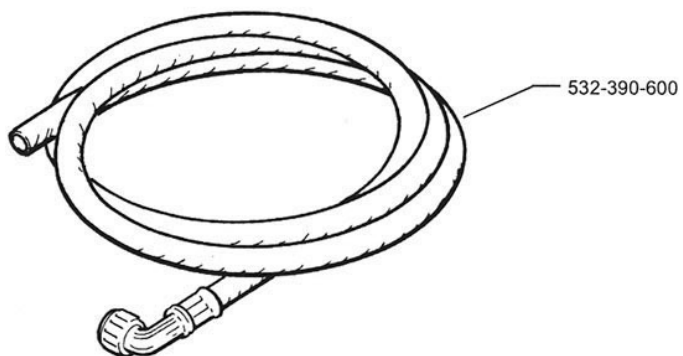

d	D	L (mm)	
1/8	1/8	220	532-302-200
1/8	1/8	260	532-303-200
1/8	1/8	370	532-300-500
1/8	1/8	550	532-302-000
1/8	1/8	2500	532-300-700
1/4	1/4	280	532-302-600
1/4	1/4	750	532-303-000
3/8	3/8	750	532-300-200

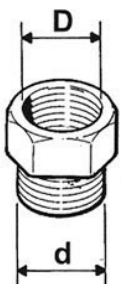

D	d	
1/8	1/2	593-580-000
3/8	1/8	593-583-000
1/8	3/8	594-529-000

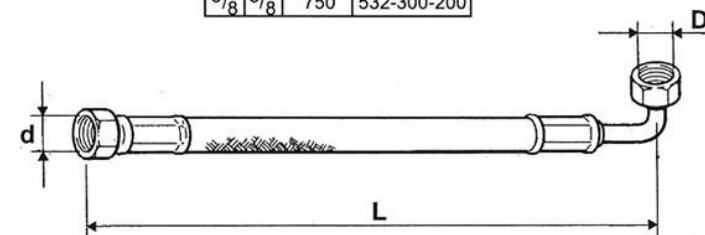

d	D	L (mm)	
3/8	3/8	2500	532-301-900

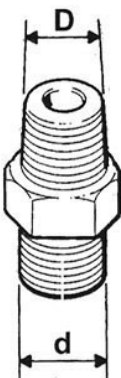

D	d	
3/8	3/8	532-500-600
3/8	1/8	532-500-500

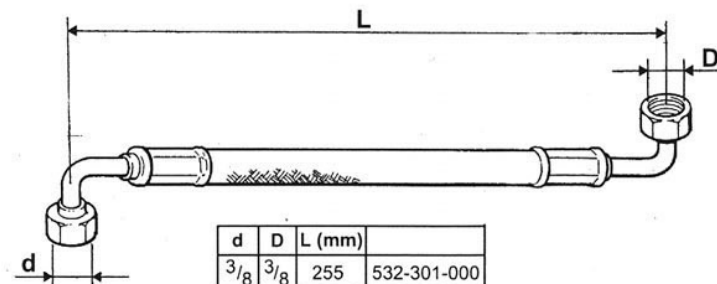

d	D	L (mm)	
3/8	3/8	255	532-301-000

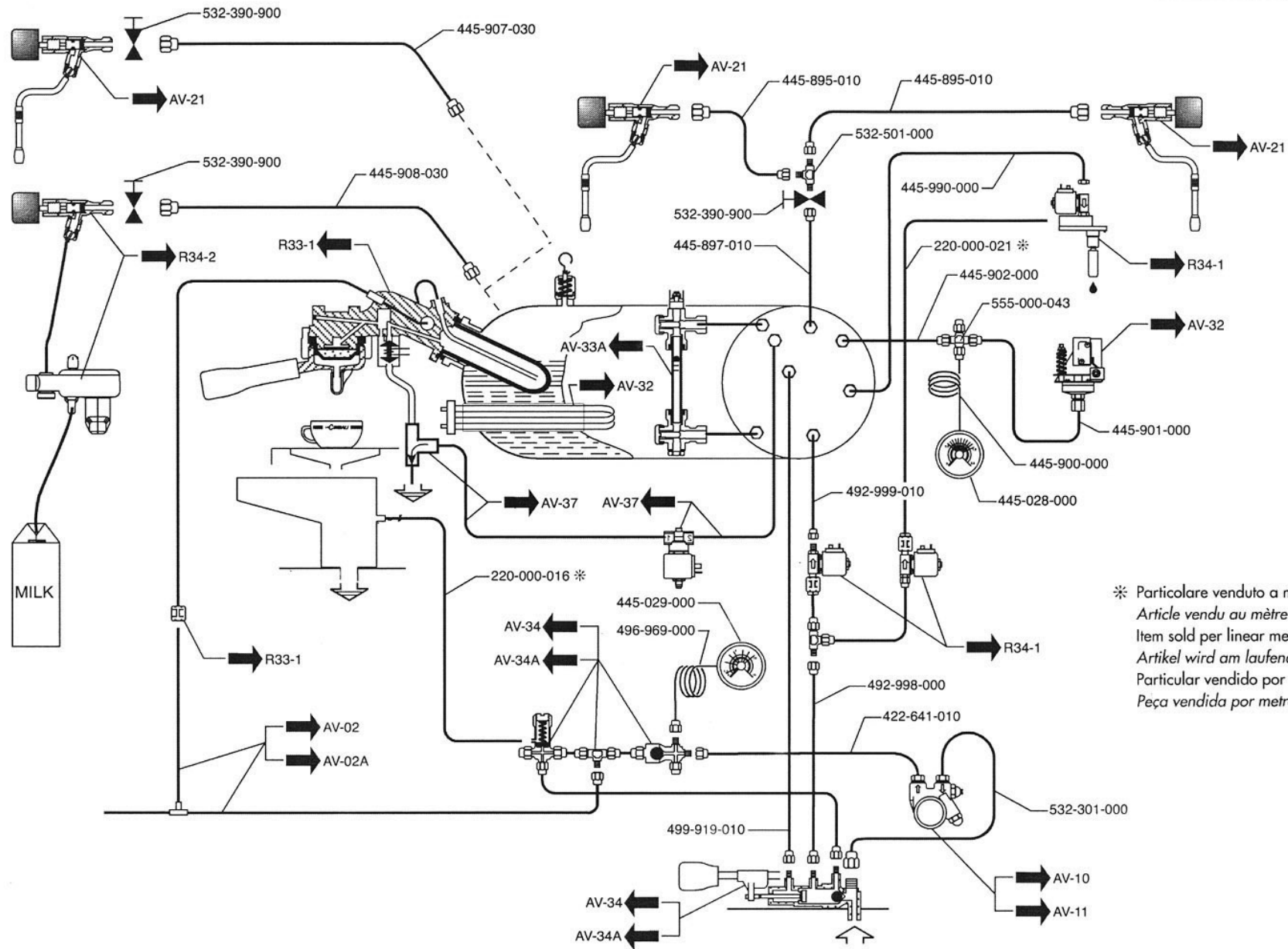

* Particolare venduto a mt. lineare
 Article vendu au mètre linéaire
 Item sold per linear meter
 Artikel wird am laufenden Meter verkauft
 Particular vendido por metros lineares
 Peça vendida por metro linear

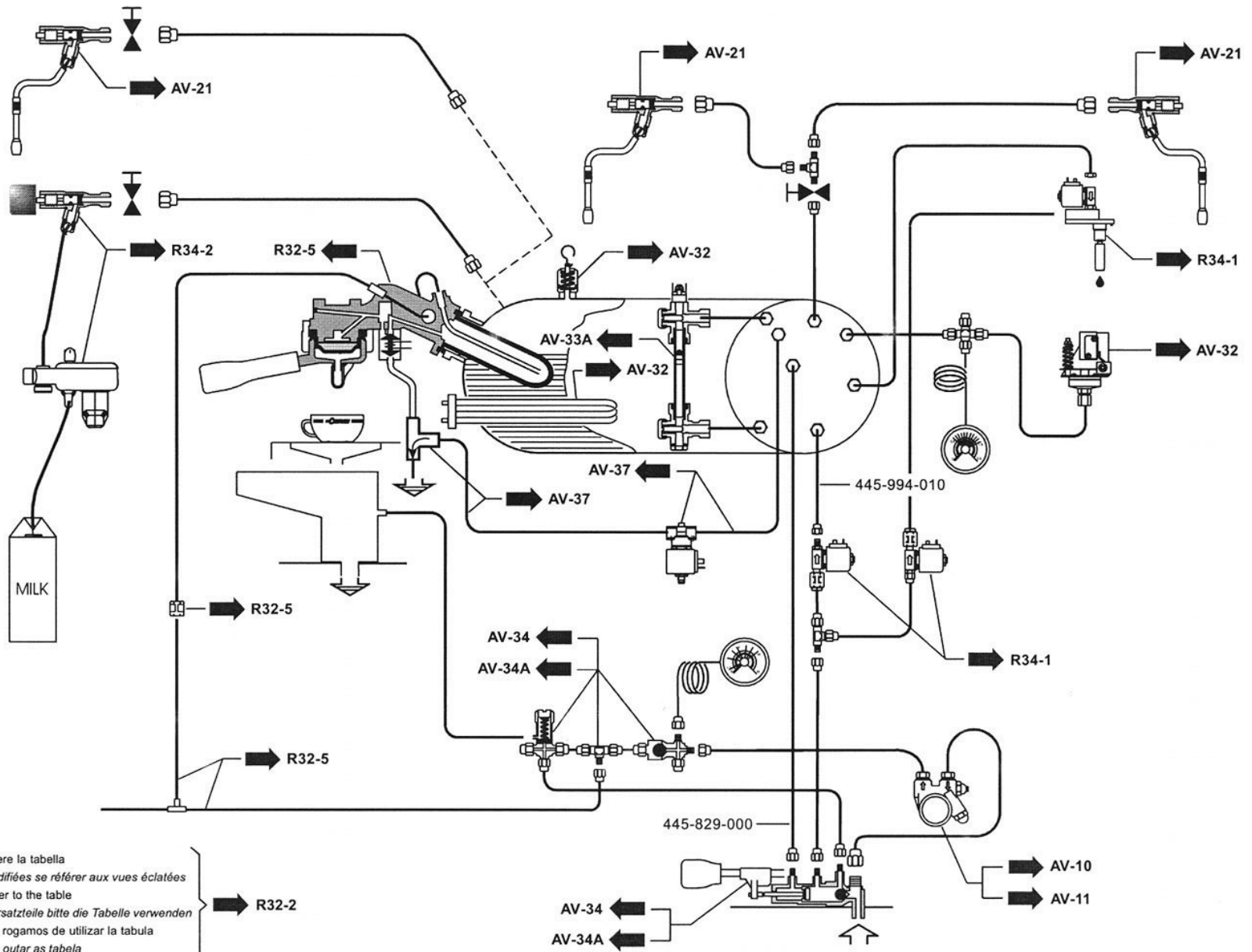

Per i particolari non codificati vedere la tabella
Pour les pieces détachées pas codifiées se référer aux vues éclatées
For the parts not listed, please refer to the table
Bezüglich der nicht kodifizierten Ersatzteile bitte die Tabelle verwenden
Por los repuestos non codificados rogamos de utilizar la tabula
Pelos particulares não codificados outar as tabela

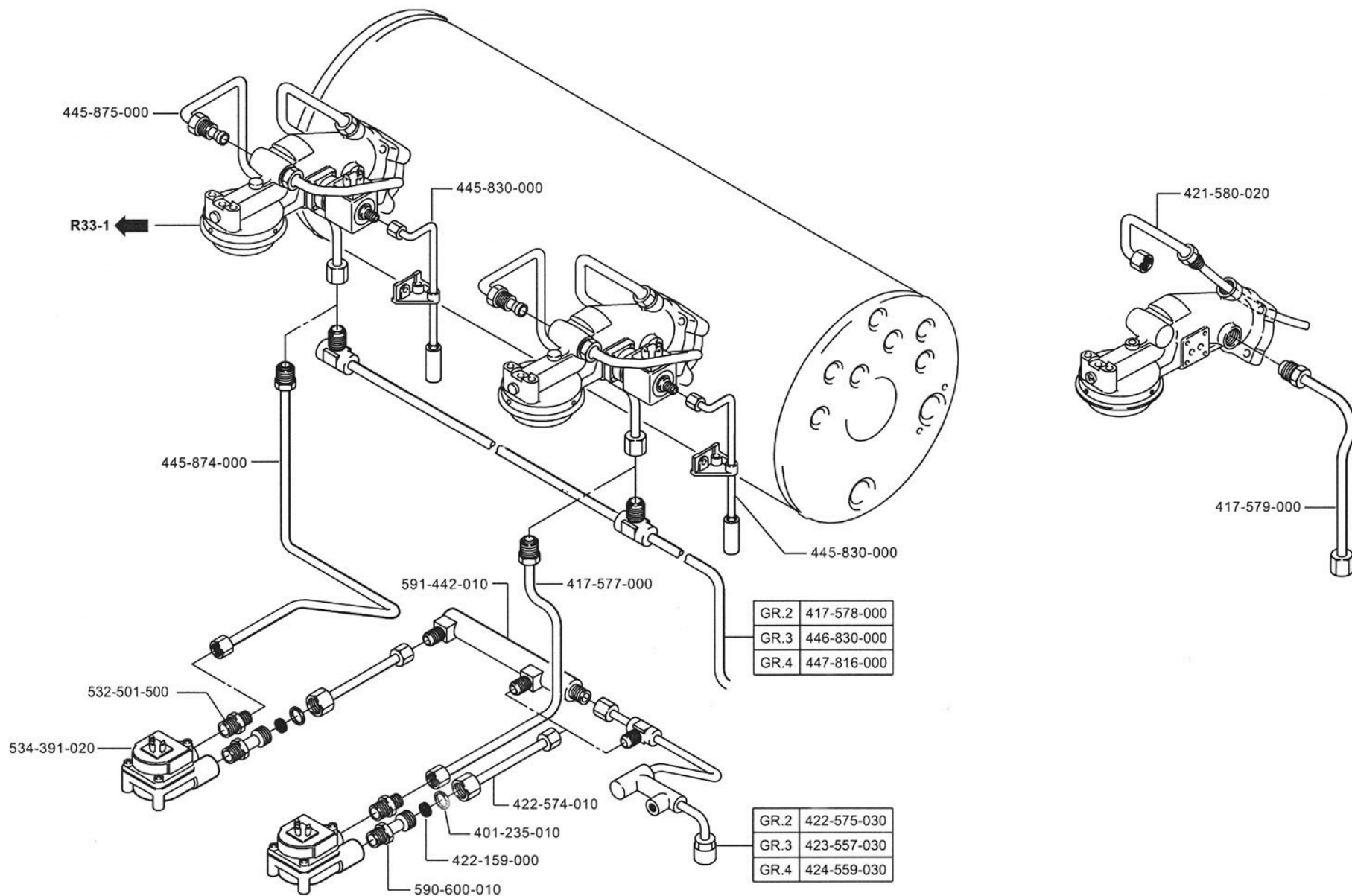

(●) Only for North-America market

■ Ø 0,5 491-150-000
 Ø 0,8 491-173-006

A 150 mm 457-177-006
 210 mm 457-207-006

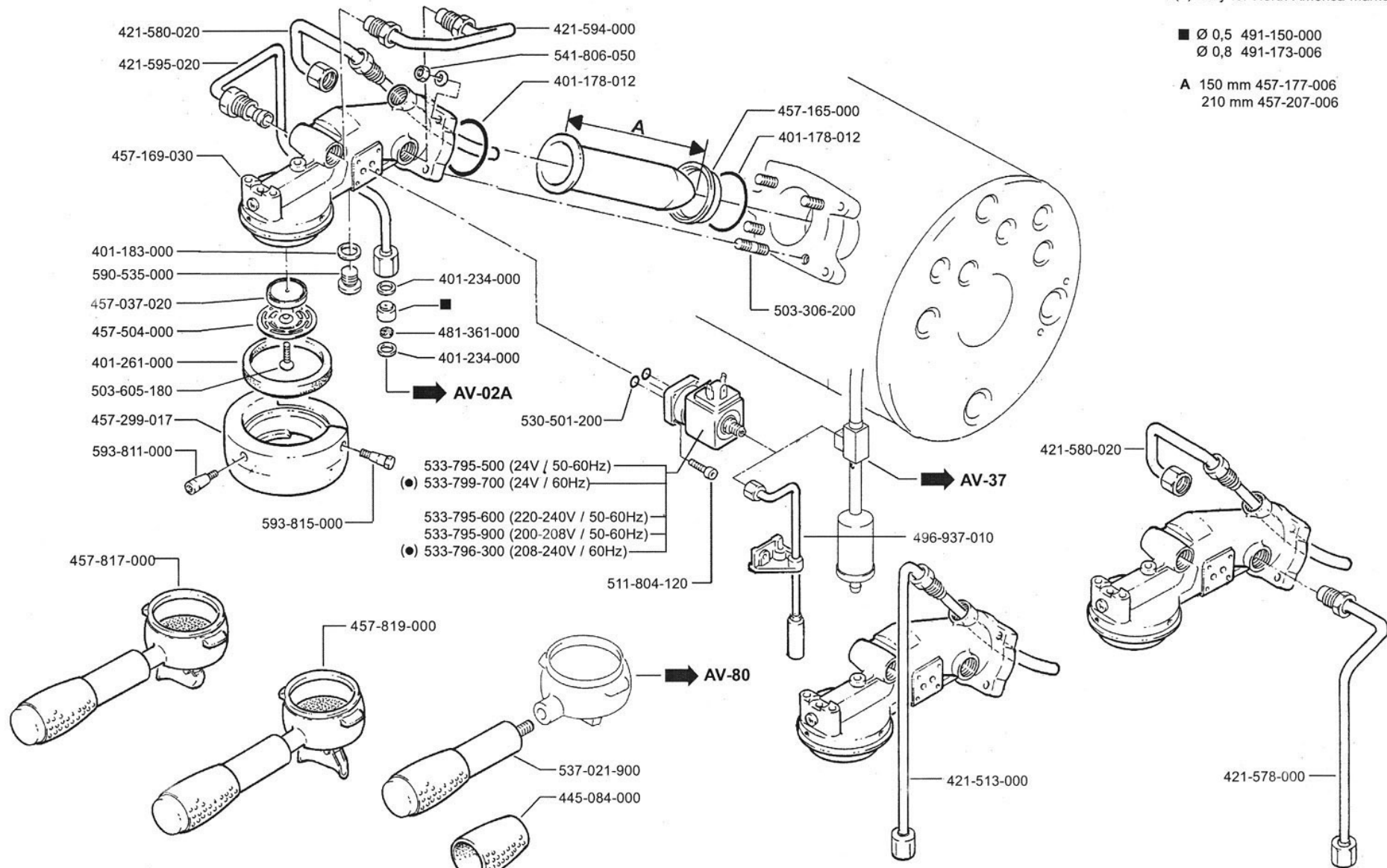

M32 CLASSIC

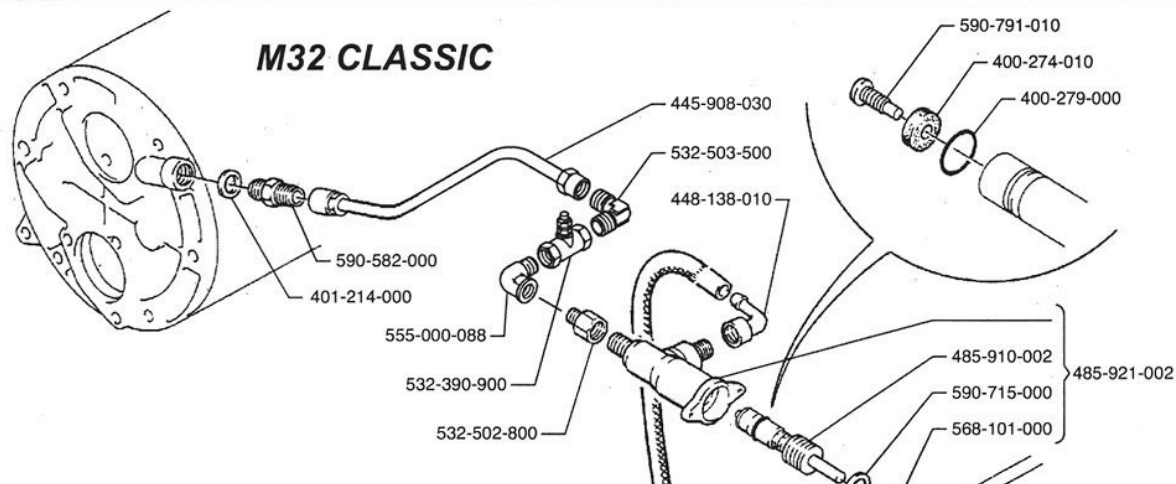

* Particolare venduto a mt. lineare
 Article vendu au mètre linéaire
 Item sold per linear meter
 Artikel wird am laufenden Meter verkauft
 Particular vendido por metros lineares
 Peça vendida por metro linear

M32 DOSATRON

