

Item no.	Part no	Reference	Description
1		<a href="#">►1</a>	Control panel
2		<a href="#">►2</a>	Electrical installation
3		<a href="#">►3</a>	Clima Plus
4		<a href="#">►4</a>	Steam generator, Bypass
5		<a href="#">►5</a>	Hot air heating
6		<a href="#">►6</a>	Motor and fan wheel
7		<a href="#">►7</a>	Interior cabinet
8		<a href="#">►8</a>	Door
9		<a href="#">►9</a>	Water supply, quenching box
10		<a href="#">►10</a>	Hand shower
11		<a href="#">►11</a>	CleanJet
13		<a href="#">►13</a>	Exterior cabinet
14		<a href="#">►14</a>	Miscellaneous

---

1	Control panel .....	3
1.A	Control panel.....	4
2	Electrical installation .....	5
2.A	Contactor assembly .....	6
2.B	Cable entry.....	8
2.B	Cable entry.....	9
3	Clima Plus.....	10
3.A	Hose set f. humidity control.....	11
4	Steam generator, Bypass .....	12
4.A	Pump connection spout cpl. ....	13
4.B	Venting valve for steam generator .....	14
5	Hot air heating .....	15
6	Motor and fan wheel .....	16
7	Interior cabinet.....	17
7.A	Interior cabinet .....	18
7.B	Gasket frame w. glass a. gaskets .....	19
7.C	Air baffle.....	20
7.C	Air baffle.....	21
8	Door .....	22
8.A	Door .....	23
9	Water supply, quenching box.....	24
10	Hand shower.....	25
11	CleanJet.....	26
13	Exterior cabinet.....	27
13.A	Exterior cabinet .....	28
14	Miscellaneous .....	29

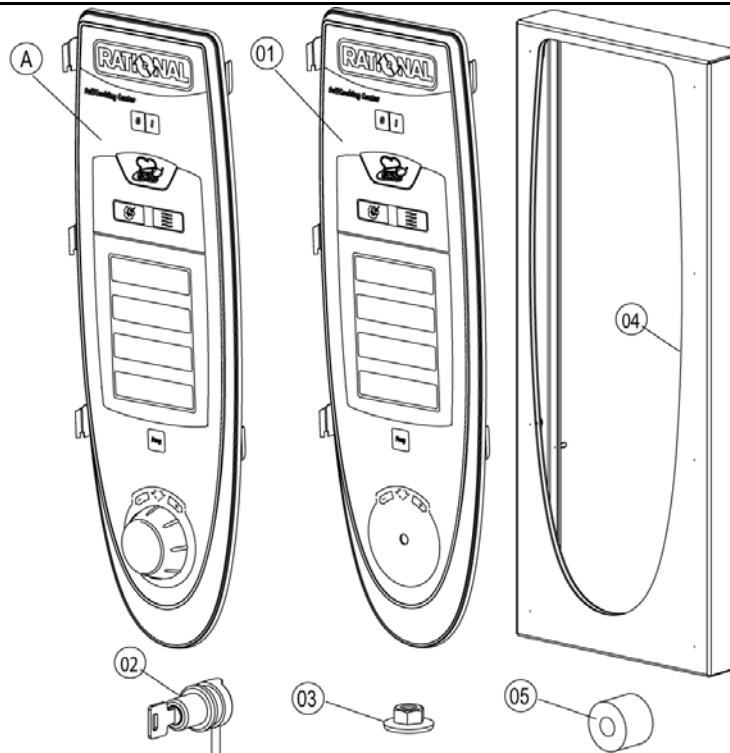

Item no.	Part no	Reference	Description
A		<a href="#">►1.A</a>	Control panel
1	87.00.000		Control panel insert with overlay

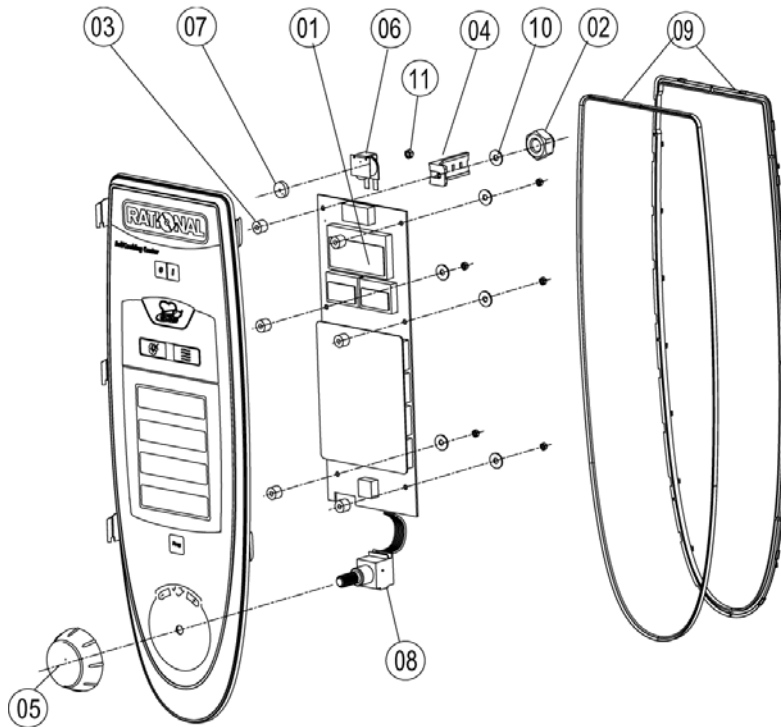

Item no.	Part no	Reference	Description
1	42.00.002		Control pcb
2	1104.0121		Hex nut M4 self locking
3	10.00.355		Spacer black
4	2020.0400		Fixing device for cable harness
5	16.00.232		Dial f. pulse generator
6	40.02.087		Buzzer
6	3006.0107		Buzzer
7	5110.1029		Gasket mode switch
7	5110.1028		Gasket poti hot air, core temperature
8	40.00.404		Pulse generator
9	16.00.387		Mounting device f.sealing + sealing lip
10	1306.0218		Washer A4,3
11	1103.0122		Hex nut M3 self-locking

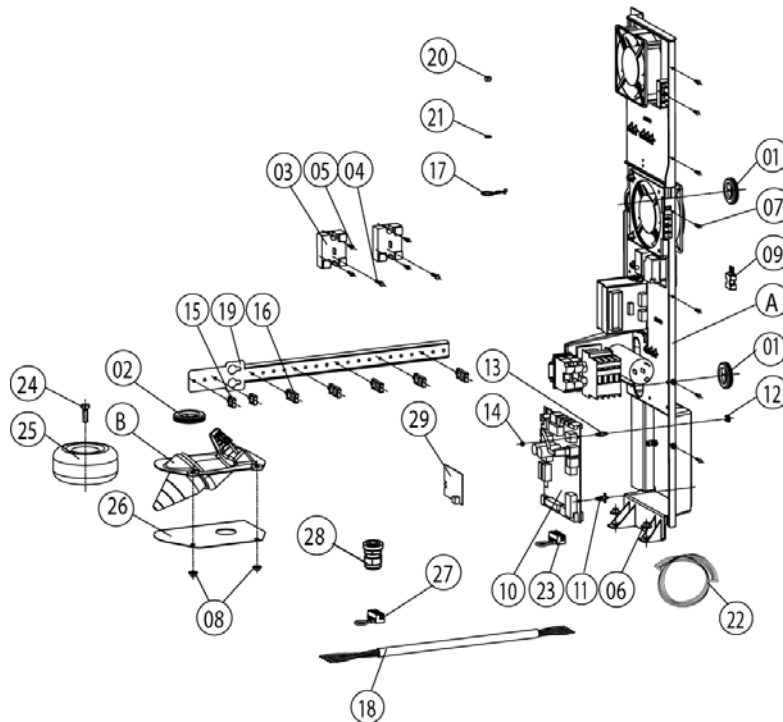

Item no.	Part no	Reference	Description
A		<a href="#">►2.A</a>	Contacteur assembly
B	40.00.609	<a href="#">►2.B</a>	Cable entry
B	40.00.306	<a href="#">►2.B</a>	Cable entry
1	4007.0620		Membrane DGC 29
2	4007.0621		Membrane DGC 36
3	40.00.453		Solid state relais
4	10.00.507		Pan head screw Torx 5/16" T20
5	10.00.444		Raised countersunk head screw Torx M4x8
6	1106.0803		Hex combination nut M6 galv
7	10.00.239		EJOT PT-Screw Torx 4x10
8	1105.0121		Hex combination nut M5 galv
9	42.00.007		External memory
10	40.00.049		Relay-I/O pcb
10	42.00.045		Relay-I/O pcb w/o Sicotronic
11	40.00.417		Fixing clip f. pcb
12	1104.0801		Cage nut M4
13	10.00.243		Spacer M4x8
14	1104.0120		Hex nut M4
15	10.00.112		Cable clip short
16	10.00.111		Cable clip long
17	10.00.471		Cable clip d10-12mm
18	40.00.593		Power supply cable 5x10mm <sup>2</sup>
19	40.01.285		Fixing device f. cable guide
20	1106.0160		Hex nut M6
21	1206.0120		Tooth lock washer A6,4
22	40.00.472		Bus cable 1.3m
23	40.00.338		Sicotronic-terminal *screw typ*
27	40.01.776		Sicotronic-terminal *crimp type*

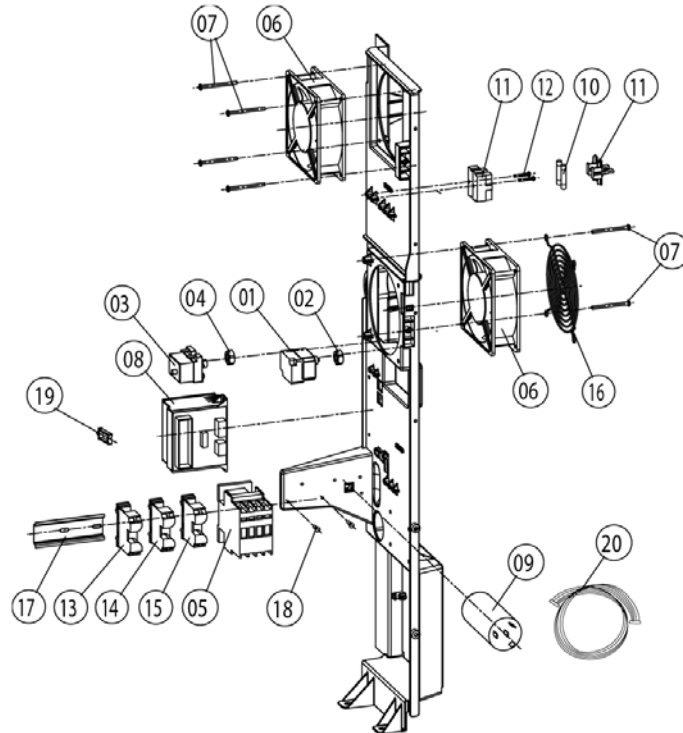

Item no.	Part no	Reference	Description
1	40.01.329		Dry up protector 160°
2	3014.0302		Hex nut M10 for dry-up protector
3	40.01.482		Safety temperature limiter 365°C
4	3014.0327		Hex nut M10x1,0
5	40.01.556		Contactor CL04A310M6-M
6	3101.1008		Cooling fan
7	10.00.238		Screw Torx 4x50
8	40.00.277		Control transformer
9	40.00.465		Electronic noise filter
10	4001.0224		Fuse 6.35x32mm
11	4001.1295		Fuse holder e 1003Si/1DS
12	10.00.240		Screw Torx 3x20
13	4001.1233		Terminal block yellow/green 35mm <sup>2</sup>
14	4001.1252		Terminal block, blue 35 mm <sup>2</sup>
15	4001.1206		Terminal block 35mm <sup>2</sup> grey
16	2005.0106		Protective grid for cooling fan
17	40.01.562		Installation rail for Contactor 115mm
17	40.00.518		Installation rail for Contactor 95mm
18	10.00.239		EJOT PT-Screw Torx 4x10
19	10.00.111		Cable clip long
20	40.00.209		Cable buzzer
20	40.00.202		Cable CDS sensor
20	40.00.234		Cable contactor-SSR
20	40.01.297		Cable control harness
20	40.00.201		Cable control SSR
20	40.00.228		Cable control SSR
20	40.00.210		Cable control transformer sec.
20	40.00.213		Cable control transformer sec.
20	40.00.207		Cable differential pressure switch
20	40.00.208		Cable humidity control



# SCC 102E

Valid as of E12SE0404 up to E12SE....

Electrical unit

## ▶ 2.A Contactor assembly

2

2 Electrical installation

Voltage 3 NAC 400V 50-60Hz

Item no.	Part no	Reference	Description
20	40.00.205		Cable level electrode
20	40.00.204		Cable SC pump
20	40.00.203		Cable solenoid valve

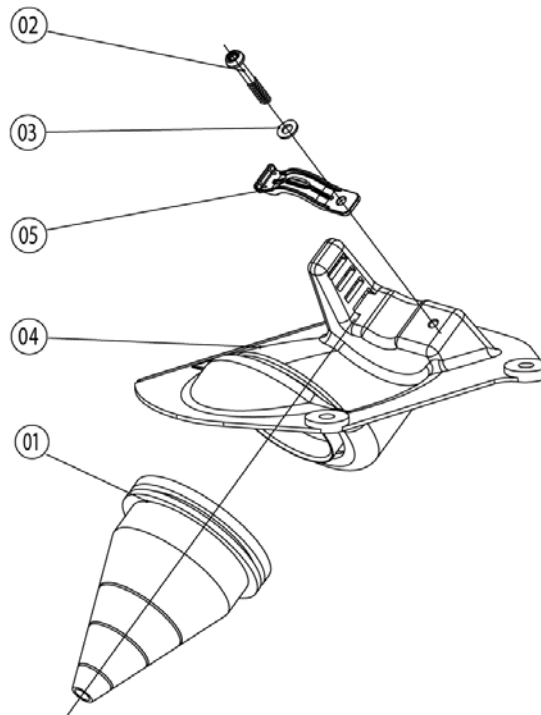

Item no.	Part no	Reference	Description
1	40.00.391		Cable bushing f. cable entry
2	10.00.076		Allen screw M5x35
3	1305.0160		Washer A5,3x10mm
4	40.00.307		Cable entry
5	40.00.312		Clamp strap f. cable entry



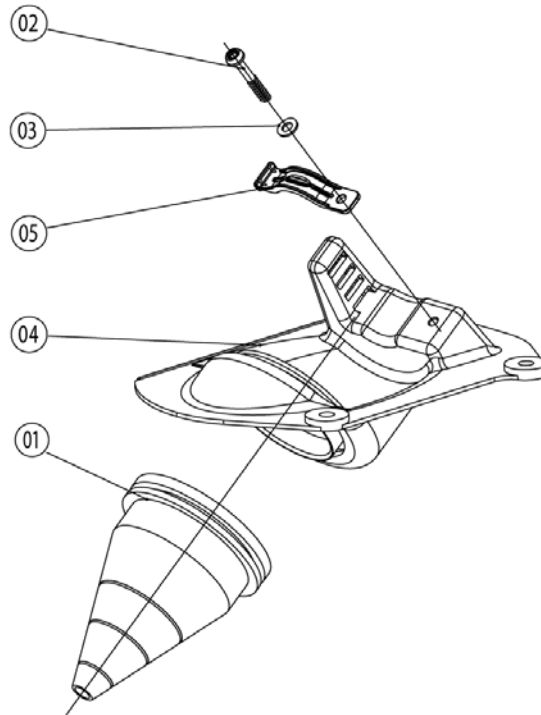

Item no.	Part no	Reference	Description
1	40.00.391		Cable bushing f. cable entry
2	10.00.115		Allen screw M5x30
3	1305.0160		Washer A5,3x10mm
4	40.00.307		Cable entry
5	40.00.312		Clamp strap f. cable entry

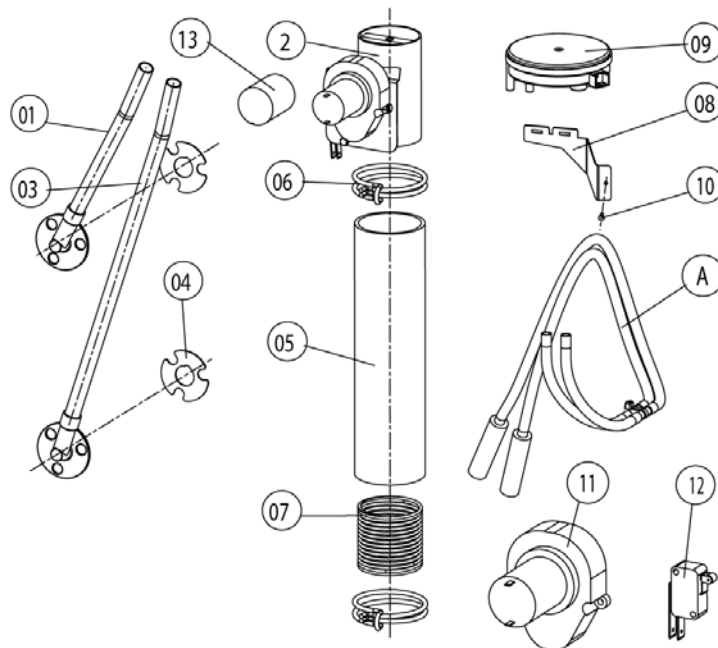

Item no.	Part no	Reference	Description
A	22.00.256	<a href="#">▶3.A</a>	Hose set f. humidity control
1	22.00.199		Inner humidity meas. Piece
2	22.00.318		Humidity control cpl. with motor
3	22.00.200		Outer humidity meas. Piece
4	22.00.198		Gasket f. hum. meas. Pipe
5	22.00.214		Hose d50x202
5	22.00.213		Hose d50x210
6	2066.0531		Hose clamp ø56
7	2001.0124		Compression spring
8	22.00.326		Mounting device f. pressure sensor
9	3017.1011		Pressure sensor for humidity control Huba 401
10	10.00.239		EJOT PT-Screw Torx 4x10
11	3101.1010		Humidity control motor
12	3016.0102		Micro switch
13	3101.1021		Protecting cap f.12VDC humidity motor

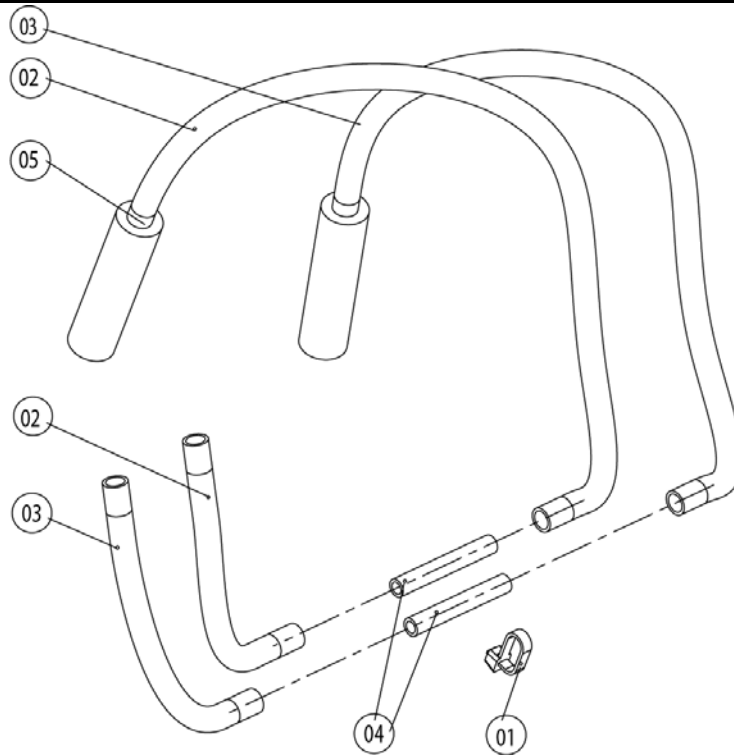

Item no.	Part no	Reference	Description
1	4005.0101		Tie rap 145 mm
2	2110.1020		Silicon hose ø5x1.5 blue
3	2110.1019		Silicone hose ø5x1,5 "red"
4	1900.0203		Ceramic tube 8x5x60mm for
5	2112.1338		Silicone hose ø8x2x20

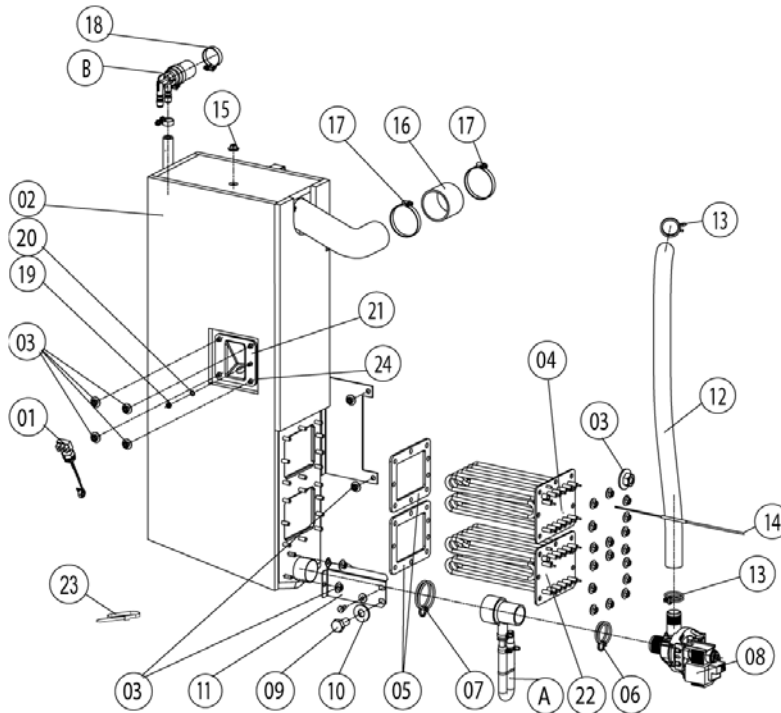

Item no.	Part no	Reference	Description
A	8354.1320	<a href="#">►4.A</a>	Pump connection spout cpl.
B	8354.1304	<a href="#">►4.B</a>	Venting valve for steam generator
1	3002.0402		Filling level electrode 90 mm
2	44.00.173		Steam generator insolated
3	1106.0803		Hex combination nut M6 galv
4	44.00.195		Heating element
5	44.00.279		Gasket f. heating element
6	2066.0519		Hose clamp 35,6mm
7	2066.0526		Hose clamp ø46mm
8	44.00.207		Emptying pump
9	1006.0762		Hex screw M6x10
10	1306.0222		Washer A6,4x15x1,5
11	44.00.232		Fixing device f. pump steam generator
12	44.00.216		Drain hose steam generator
13	2066.0518		Hose clamp 30mm
14	40.00.291		Thermocouple steam generator
15	1104.0122		Hex combination nut M4 galv
16	2112.1006		Steam hose 50x7mm
17	2066.0504		Hose clamp 40-60mm
18	2066.0506		Hose clamp 20-32mm
19	1105.0120		Hex nut M5
20	1205.0120		Tooth lock washer A5,3
21	2920.1300		Level elektrode insert
22	44.00.533		Heating element w/o pipe
23	10.00.414		Cable strap black 120°
24	44.00.280		Gasket f. heating element+Level elektrode insert

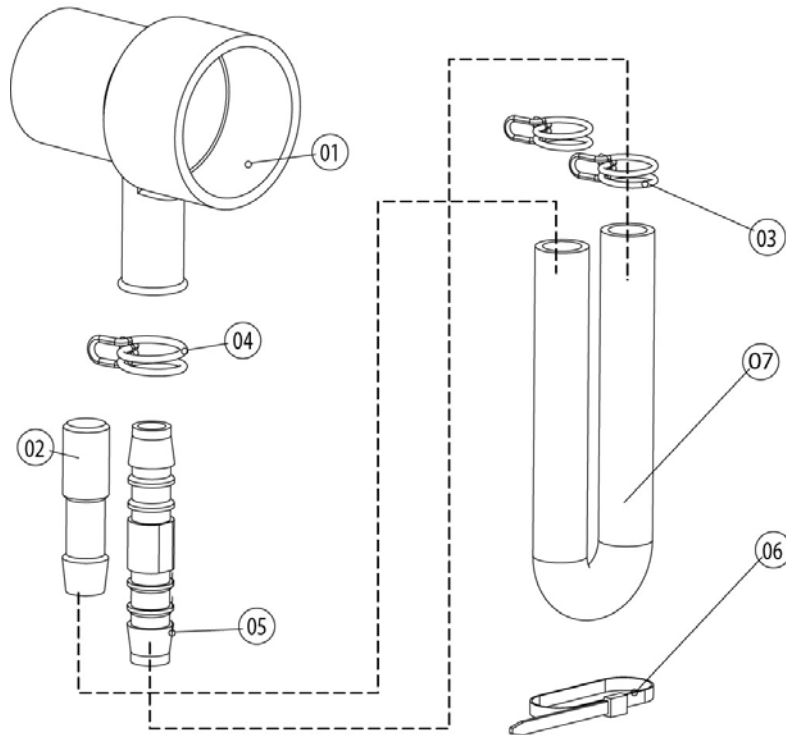

Item no.	Part no	Reference	Description
1	2118.1000		Pump connection spout
2	2120.1259		Stop plug 10mm
3	2066.0527		Hose clamp ø14mm
4	2066.0530		Hose clamp ø16.4mm
5	2062.0331		Junction pressure hose GS 10
6	4005.0101		Tie rap 145 mm

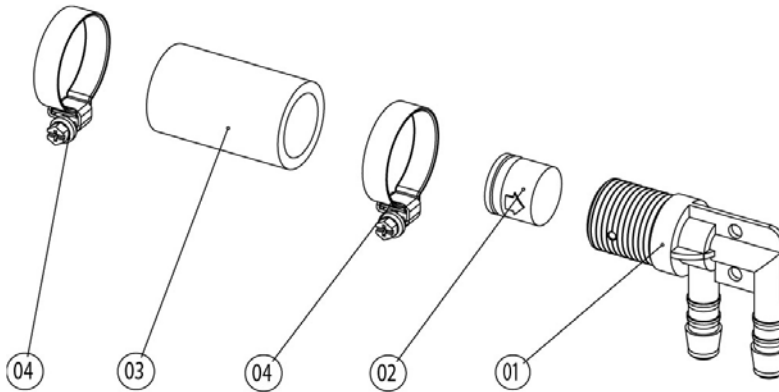

Item no.	Part no	Reference	Description
1	2062.0332		Receptacle for ventilation valve SG
2	2069.0108		Ventilation valve
3	2112.1310		Form hose for ventilation of steam generator
4	2066.0506		Hose clamp 20-32mm

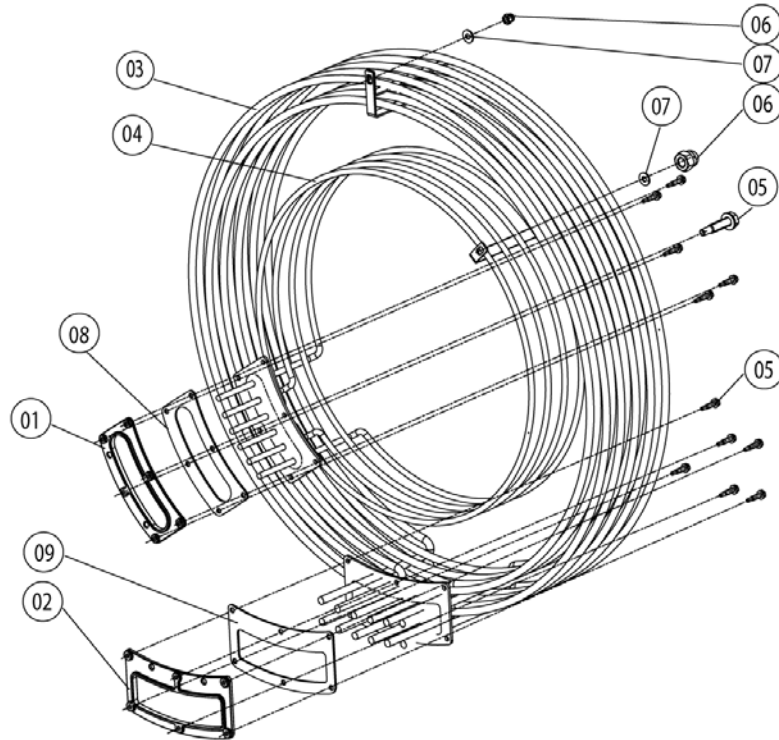

Item no.	Part no	Reference	Description
1	40.00.305		Mating flange f. heating assembly
2	40.00.330		Mating flange f. heating assembly
3	40.00.267		Heating assembly
4	40.00.271		Heating assembly
5	10.00.109		Hex screw M5x23
6	1106.0360		Cap nut M6, high shape
7	1306.0222		Washer A6,4x15x1,5
8	40.00.332		Gasket f. heating assembly
9	40.00.331		Gasket f. heating assembly

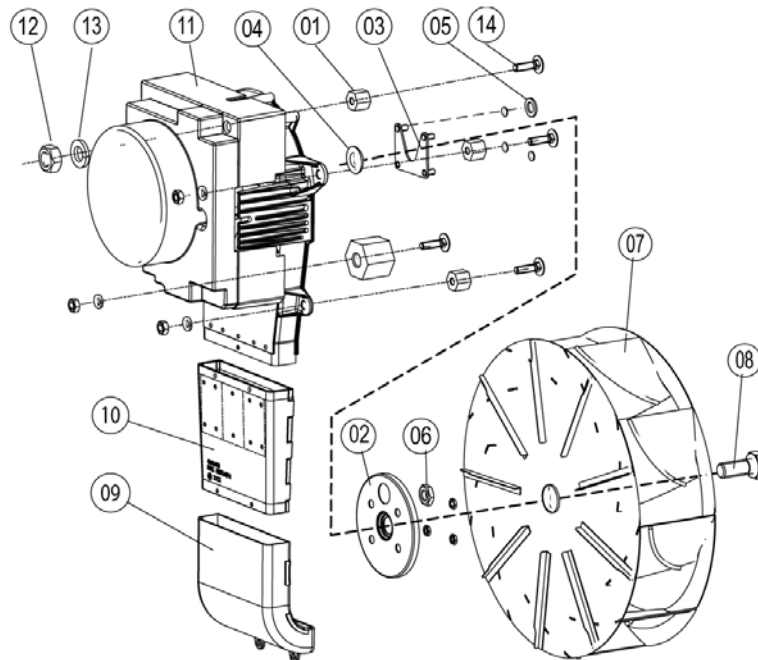

Item no.	Part no	Reference	Description
1	2120.1306		Spacer SW19x17
2	22.00.123		Flange f. motor shaft gasket
3	22.00.120		Mounting support f. gasket flange
4	22.00.083		Motor shaft gasket
4	5001.0207		Motor shaft gasket
5	1315.0101		Copper washer 6x10
6	1106.0220		Hex nut M6 flat
7	22.00.192		Fan weel d340x135
8	1008.0763		Hex screw M8x20
8	10.00.565		Hex screw M8x20
9	40.00.310		Exhaust pipe below
10	40.00.435		Exhaust channel f. SSR
11	40.00.274		Fan motor
11	40.00.275		Fan motor
12	10.00.071		Hex nut M8
12	1108.0260		Hex nut M8
12	10.00.710		Hex nut M8 w. locking
13	1208.0260		Spring washer B8
14	1008.1005		Square necked mushroom head bolt 8x40



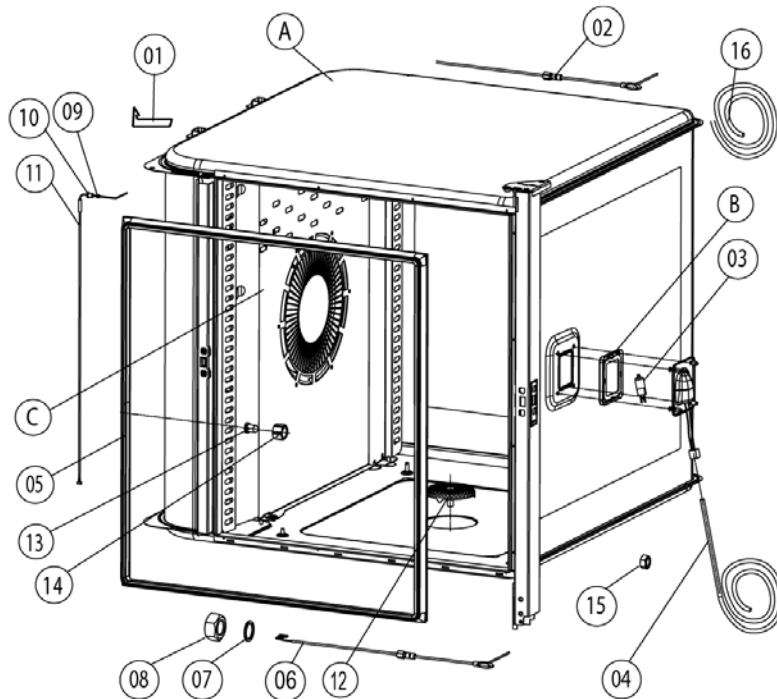

Item no.	Part no	Reference	Description
A		<a href="#">►7.A</a>	Interior cabinet
B	40.00.091	<a href="#">►7.B</a>	Gasket frame w. glass a. gaskets
C	22.00.296	<a href="#">►7.C</a>	Air baffle
C	22.00.383	<a href="#">►7.C</a>	Air baffle
1	40.00.520		Screen interior cabinet sensor
3	3024.0201		Halogen bulb for interior cabinet 300°C
4	40.00.223		Wiring interior light
5	20.00.397		Door gasket
6	40.00.606		Meat probe sensor
6	40.00.295		Meat probe sensor
7	1315.0104		Copper washer 16x20x1,5
8	10.00.422		Hex nut M16
9	3014.0162		Sealing cone for thermocouple
10	3014.0163		Gasket sleeve with nipple
11	40.00.395		Thermocouple interior cabinet
12	2005.0308		Outlet sieve
13	50.00.395		Nozzle f. moistening
14	50.00.394		Union nut M12x12
15	10.00.070		Hex nut M6

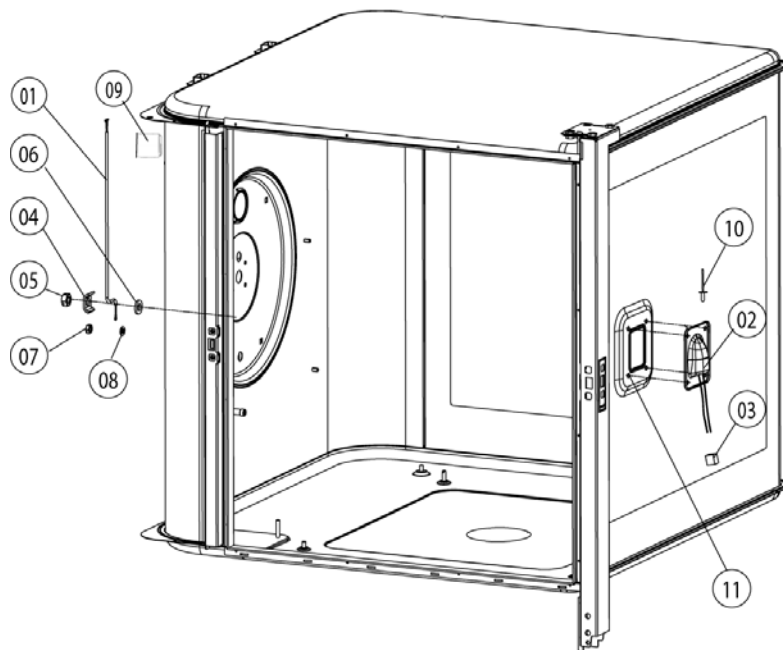

Item no.	Part no	Reference	Description
1	40.00.290		Thermocouple humidity
2	40.00.098		Reflector f. interior light
3	4001.1248		Porcelain connector 2-pin interior light
4	1330.0100		Clamp strap f. sensor
5	1106.0224		Hex nut M6 self locking
6	1306.0120		Washer A6,4
7	1104.0120		Hex nut M4
8	1204.0120		Tooth lock washer A4,3
9	2120.1277		Base for sensor connection
10	1603.0167		Tubular rivet 3,2x0.25x10
11	10.00.041		Rivet nut M5 hexagon closed

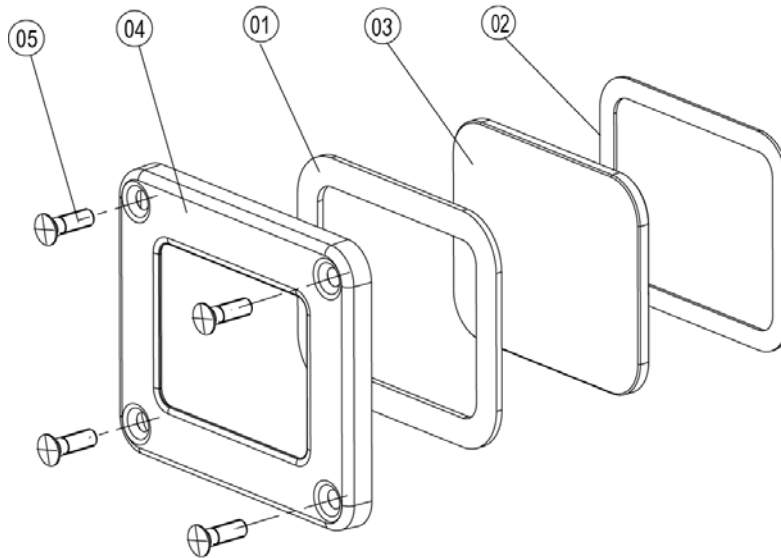

Item no.	Part no	Reference	Description
1	40.00.093		Outer gasket f. interior light
2	40.00.094		Inner gasket f. interior light
3	40.00.095		Glass pane f. interior light
4	40.00.096		Gasket frame f. interior light
5	10.00.682		Phillips countersunk-head screw M5x16

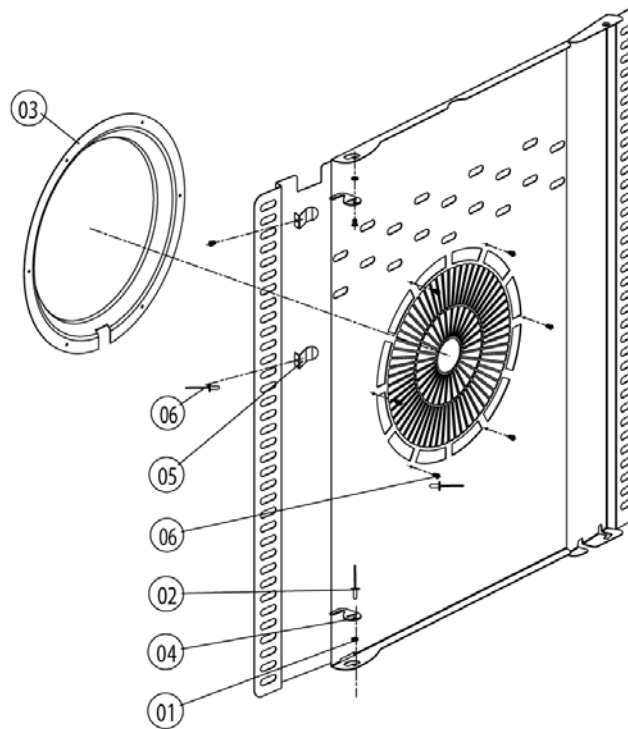

Item no.	Part no	Reference	Description
1	1304.0160		Washer A4,3
2	1604.0167		Rivet 4x10
3	22.00.332		Air sucking ring f. air baffle
4	2760.1370		Latch hook for air baffle
5	40.01.289		Fixing clip core temp. cable
6	1603.0168		Rivet 3,2x8 A4
6	1603.0168		Rivet 3,2x8 A4

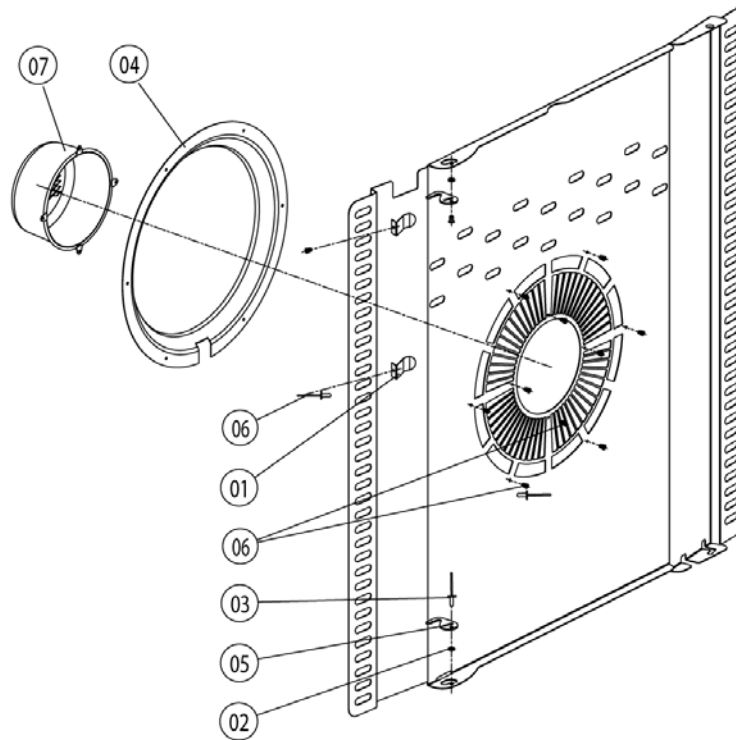

Item no.	Part no	Reference	Description
1	40.01.289		Fixing clip core temp. cable
2	1304.0160		Washer A4,3
3	1604.0167		Rivet 4x10
4	22.00.332		Air sucking ring f. air baffle
5	2760.1370		Latch hook for air baffle
6	10.00.515		Rivet 3,2x5 A4
6	1603.0168		Rivet 3,2x8 A4
7	22.00.361		Deep-draw f. air baffle

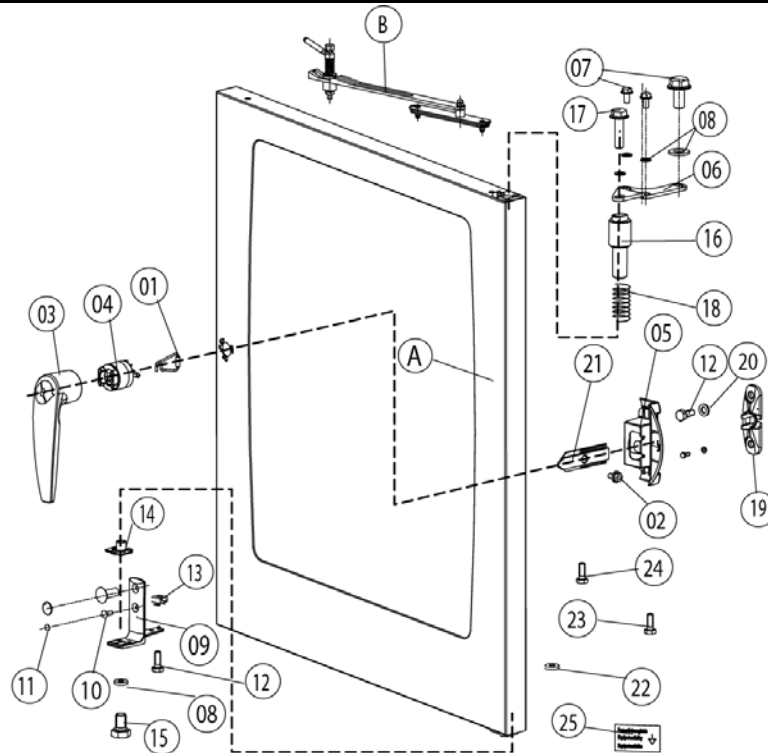

Item no.	Part no	Reference	Description
A	24.00.113	<a href="#">▶8.A</a>	Door
1	24.01.100		Spring clip f. door lock
2	1005.2000		Interlocking tooth screw M5x8
3	24.00.152		Door handle
4	24.00.176		Door lock
5	24.00.504		Lock cover
6	24.00.133		Door mounting support top
7	1008.0768		Ornamental screw M8x16
8	1308.0160		Washer A8,4
9	24.00.223		Door mounting support bottom
10	1006.1962		Countersunk screw Torx M6x16
11	10.00.090		Cap f. Torx T30
12	1006.0760		Hex screw M6x16
13	1106.0802		Cage nut M6
14	24.00.137		Door bolt
15	10.00.099		Hex screw M8x12
16	24.00.048		Door bolt
17	1008.0769		Ornamental screw M8x30
18	2001.0109		Compression spring
19	24.00.141		Holding bracket f. door catch
20	1306.0120		Washer A6,4
21	24.00.142		Door catch
22	1308.0162		Washer A8,4
23	24.01.200		Pan head screw Torx M4x12 T20
24	24.01.199		Slotted pan head screw M6x45 *WDS*

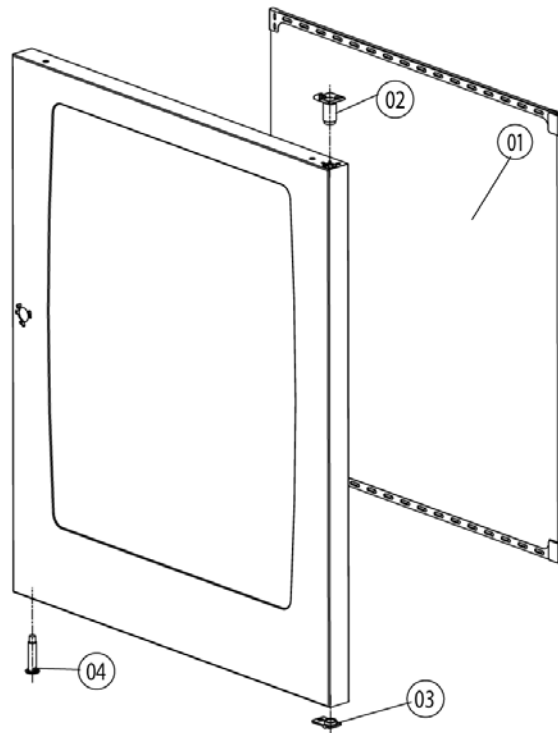

Item no.	Part no	Reference	Description
1	24.00.200		Inner glass pane
2	24.00.147		Sleeve for door bolt top
3	24.00.146		Door setting bolt
4	24.00.502		Fixing device f. magnet with magnet

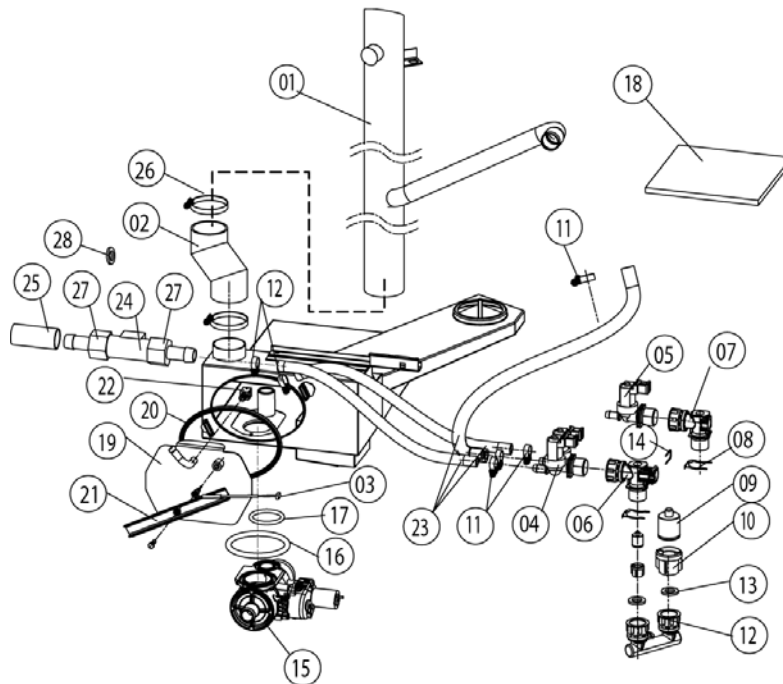

Item no.	Part no	Reference	Description
1	54.00.220		Exhaust pipe
2	54.00.094		Rubber form piece venting pipe
3	40.00.287		Thermocouple quenching
4	50.00.138		Double solenoid valve
5	50.00.139		Single solenoid valve
6	50.00.070		Water distribution hor roll guide con.
7	50.00.071		Water distribution hor. w/o roll guide con.
8	50.00.086		Locking plate f. water distribution
9	50.00.078		Non return valve DW16/DN12
10	1900.0202		Water filter
11	2066.0205		Hose clamp 8-16x9 mm SW 7mm
12	8664.1301		T-fitting water connection
13	5110.1024		Gasket for G3/4" threaded joint
14	50.00.085		Plug-in spring f. hand shower roll guide
15	54.00.357		Ball valve drain SCC cpl.
16	10.00.511		O-ring for ball valve drain 46x3.5
17	10.00.512		O-ring for ball valve drain 26x3.5
19	54.00.228		Inspection lid f. quenching chamber
20	5012.0566		Gasket quenching chamber O-ring
21	54.00.225		Clamping bar
22	2016.0942		Quenching nozzle rear double spre
23	2067.0050		Pressure hose d10mm
24	44.00.670		Water volume sensor with wire
25	2112.1346		Protecting hose ø28x2x70mm
26	2066.0516		Hose clamp 60-80 mm
29	2120.1277		Base for sensor connection



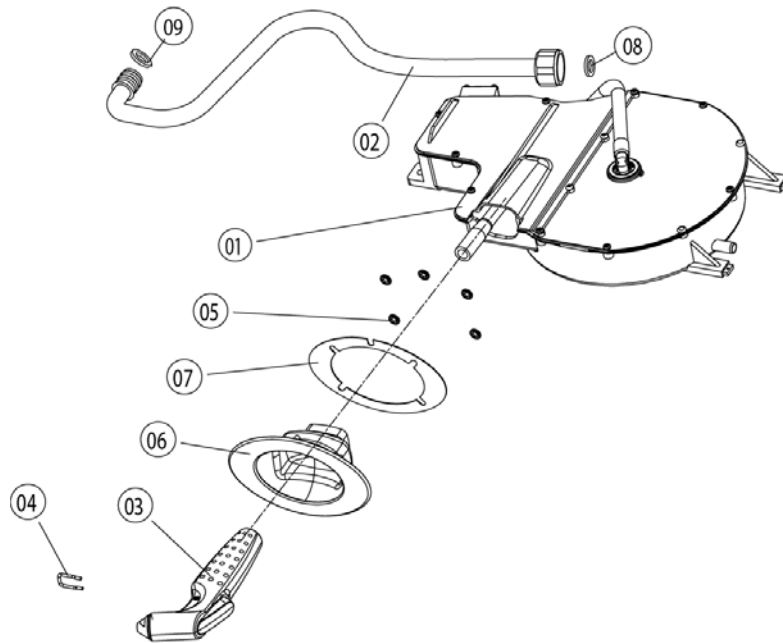

Item no.	Part no	Reference	Description
1	50.00.140		Hand shower roll guide
2	50.00.174		Connect. pipe f. hand shower roll guide
3	50.00.130		Hand shower
4	50.00.156		Clamp f. hand shower roll guide
5	1107.0100		Star lock ø4
6	50.00.279		Tulip for handshower
7	50.00.298		Tape f. tulip
8	50.00.537		Gasket f. connect.pipe hand shower roll guide
9	50.00.538		O-ring f. connect. pipe f. hand shower roll guide

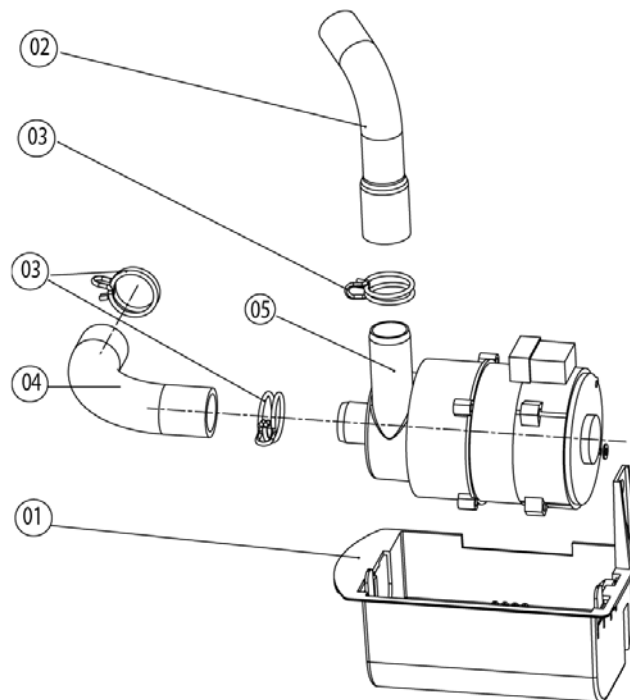

Item no.	Part no	Reference	Description
1	12.00.319		Housing f. Cleaning pump
2	56.00.166		Pressure hose f. cleaning
3	2066.0521		Hose clamp 27mm
4	56.00.120		Suction hose f. cleaning
5	56.00.153		Pump f. cleaning UP30

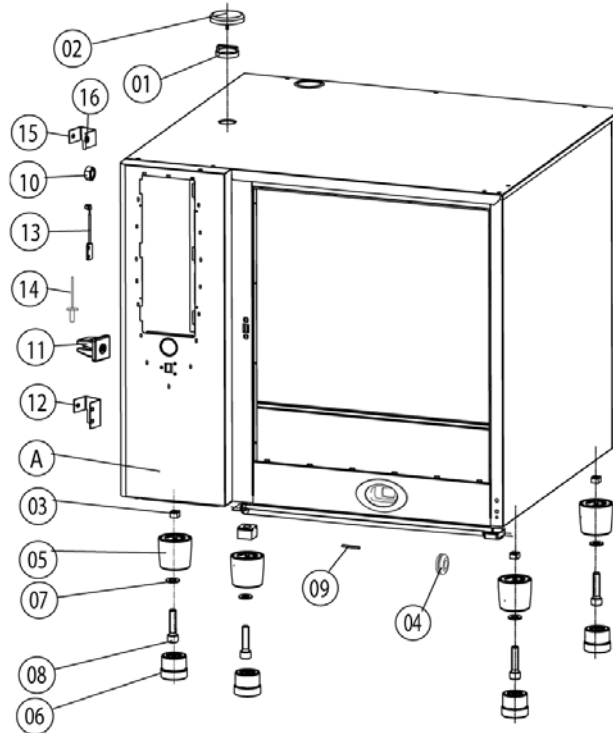

Item no.	Part no	Reference	Description
A		<a href="#">►13.A</a>	Exterior cabinet
1	22.00.354		Spacer ring
1	8450.1310		Spacer ring
2	22.00.353		Vent cover
2	8455.1209		Vent cover
3	1110.0800		Cage nut M10
3	1110.0800		Cage nut M10
4	2022.0101		Grommet 18 mm
5	12.00.205		Upper part of pedestal
6	12.00.206		Lower part of pedestal
7	1328.0102		Safety washer A10,2
8	10.00.107		Allen screw M10x30
12	16.01.146		Bracket for door contact switch

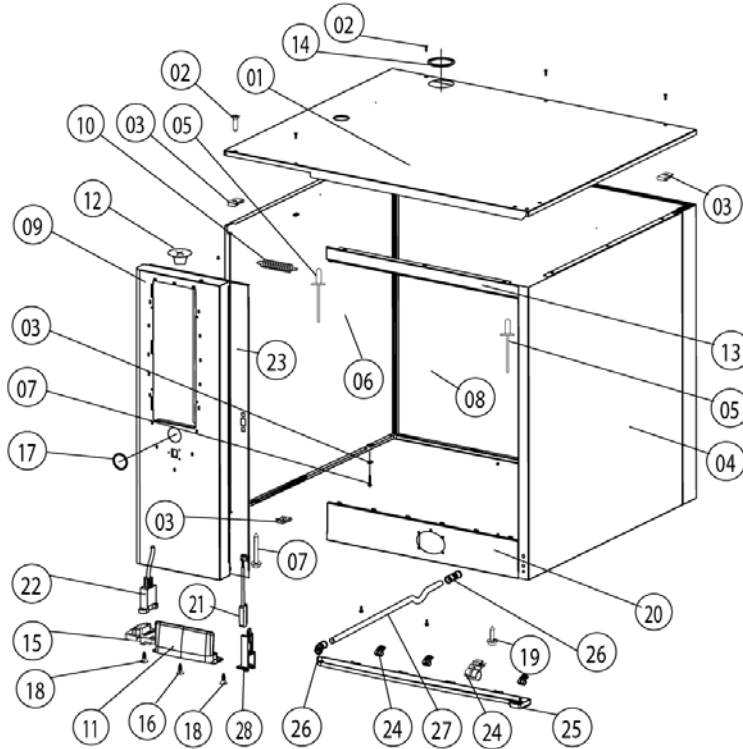

Item no.	Part no	Reference	Description
1	16.00.340		Top cover
2	1003.2265		Countersunk self tapping screw 4,2x16
3	1104.0820		Snap nut 4,2mm
4	16.00.154		Side panel right
5	1603.0166		Rivet 3,2x7,9 CNS closed
6	16.00.155		Side panel left
7	10.00.102		Hex self tapping screw B4,2x32
8	16.00.188		Back panel
9	16.00.299		Front panel
10	2002.0107		Tension spring for front panel
11	16.00.673		Air inlet filter
12	2039.0331		Cap for service door
13	16.00.331		Crossbar top
14	5105.1028		Gasket f. breather tube d=74mm
15	16.00.329		Cover f. USB interface
16	10.00.103		EJOT PT-screw KA 3.5x10
17	16.00.338		Edge protection profile
18	10.00.460		EJOT PT-Screw Torx 3,5x14
19	1004.2160		Hex self tapping screw 4,2x16
20	16.00.322		Crossbar below f. tulip
21	40.00.335		Door switch
22	40.00.469		Interface cable USB 0.9m
23	16.00.681		Crossbar front panel
24	50.00.296		Clip f. drip collector
25	50.00.300		Drip collector
26	50.00.303		Bushing drip collector
27	50.00.304		Drain drip collector
27	50.00.557		Drain drip collector
28	16.00.384		Bracket for door contact switch

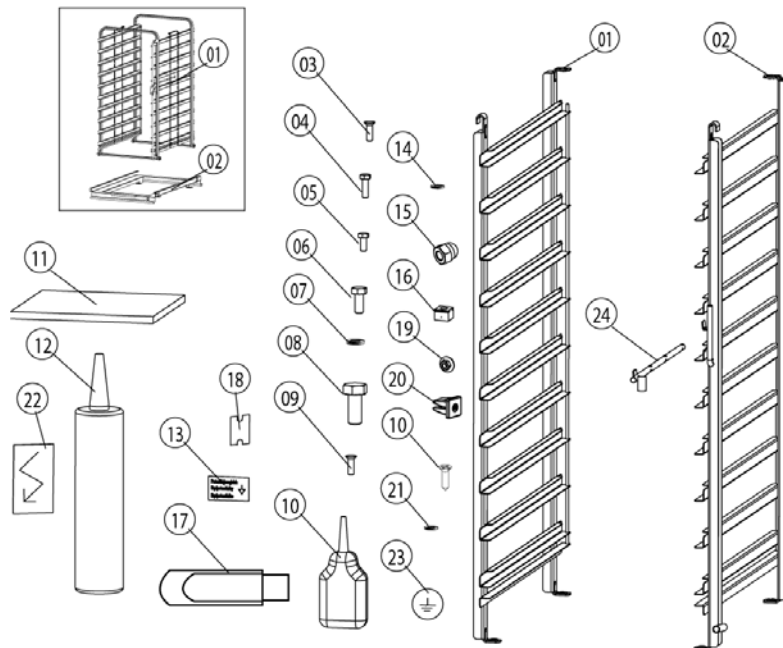

Item no.	Part no	Reference	Description
1	60.12.003		Hinging rack left
2	60.12.004		Hinging rack right
3	10.00.448		Phillips countersunk-head screw M5x16
4	1008.0750		Hex screw M5x16
5	1004.0666		Hex screw M4x10
6	10.00.565		Hex screw M8x20
7	1208.0160		Tooth lock washer A8,4
17	42.00.029		USB-Memory-Stick
19	1105.0123		Hex combination nut M4
22	4019.0008		Sticker Electric/Danger
24	60.60.574		Positioning support f. core sensor