



THE PROGRAMMABLE CONTROL SYSTEM

MK-IV



User's Manual

General descriptions MODES

The system contains six different modes:

1. **MANUAL MODE:** The mode when the mixer is operated like a manual controlled mixer. Instead of executing a programmed recipe, the mixer is started and operated until it is manually shut off.
2. **PROGRAMMING MODE:** The mode where all programming and editing takes place.
3. **PROGRAM MODE:** The mode where all programmed recipes are executed.
4. **FIXED MODE:** A pure executional mode, mixer will only run the programmed recipes. Neither editing or speed/time overwriting can take place. Manual mode is void.
5. **RPM MODE:** Computer displays the speed in actual R.P.M.
6. **SPEED MODE:** Computer displays the speed.
(speed 1, 2, 3 and 4)

The Keypad

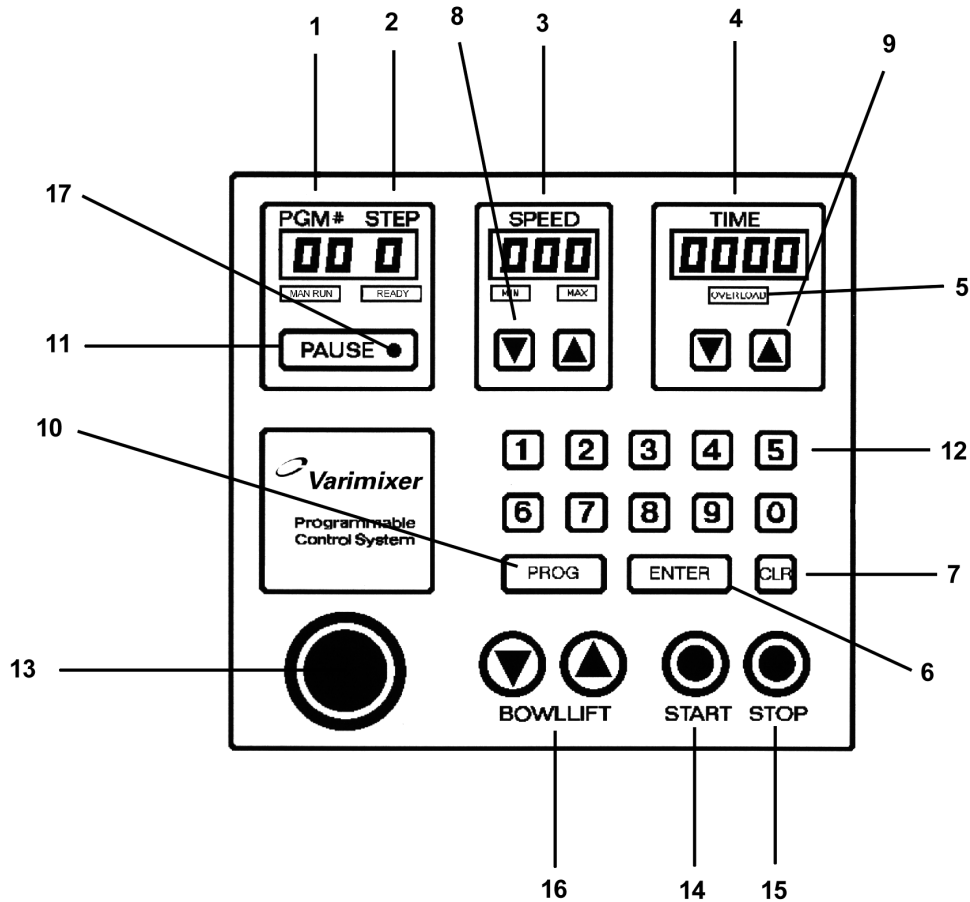

The Keypad is used for entering data to the system.

<u>ITEM</u>	<u>FUNCTION</u>	<u>EXPLANATION</u>
1.	Program No.	Displays the program Number being executed.
2.	Step	Displays the step number being executed.
3.	Speed	Displays the set-speed.
4.	Time	Displays the elapsed time since start <i>or</i> displays the remaining time to shut down.
5.	Text Area	<p><u>OVERLOAD:</u> Mixer cannot maintain set speed, too much mix or speed set too high.</p> <p><u>MIN SPEED:</u> The mixer is running at absolute minimum speed.</p> <p><u>MAX SPEED:</u> The mixer is running at absolute maximum speed.</p> <p><u>READY:</u> The mixer is ready to start.</p>

<u>ITEM</u>	<u>FUNCTION</u>	<u>EXPLANATION</u>
6.	Enter	Used for stepping through a program.
7.	CLR	Clears a flashing display.
8.	Speed up/down arrows.	Used for adjusting the the speed while the mixer is running.
9.	Time up/down arrows.	Used for adjusting the the time.
10.	Program	Used to enter/exit program-programming mode.
11.	Pause	Pauses the mixer without losing recipe.
12.	Numeric keys	Used for setting time and speed.
13.	Emergency Stop	Stops the mixer instantly.
14.	Start	Starts the mixer.
15.	Stop	Stop and reset key - reduces the speed to minimum and stops the mixer.
16.	Bowl Lift	If available, used for raising and lowering the mixing bowl.
17.	Green L.E.D.	Lights up when mixer is paused.

How to run the mixer manually.

R.P.M. Mode.

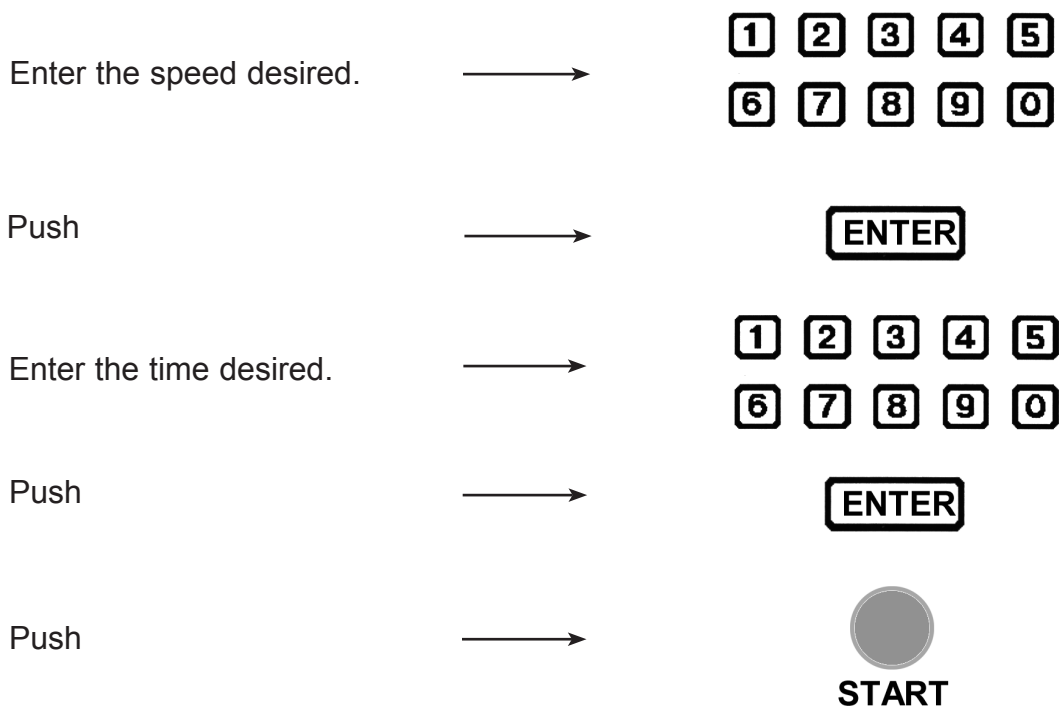

How to run the mixer manually.

SPEED Mode.

Enter the speed desired.



Push



Enter the time desired.



Push



Push



START

How to input a program.

A flashing display indicates that it is expecting the operator to key in a value.

A step is always a combination of speed and time.

An example is 100 R.P.M. for 5:00 minutes or 0 R.P.M. for 15 seconds (which is a 15 second pause)

Please note that the mixer will not start automatically after a pause, the start button must be pushed to proceed to the next step.

Up to 25 programs , each consisting of 9 steps , can be stored in memory.

A Sample Program

<u>Program Number</u>	<u>Step</u>	<u>Speed</u>	<u>Time</u>
1	1	60	1:00
	2	200	5:00
	3	0	:20
	4	110	4:00
	5	180	2:00
	6	0	0:00

“0” Speed and “0” Time in the last step is mandatory. The control system will read it as a “end of program” mark.

To program a recipe.

Push → **PROG**

“HOLD FOR 3 SECONDS”

Push → **ENTER**

Push → **ENTER**

Enter the speed desired. →

1	2	3	4	5
6	7	8	9	0



Push → **ENTER**

Enter the time desired. →

1	2	3	4	5
6	7	8	9	0

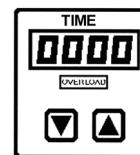

Repeat this process for as many as 9 steps per program, after the 9th step, the next program number will display, ready to enter a new recipe. This will continue up to 25 programs.

Example



To edit a recipe or to correct mistakes, use the same step above to enter the programming mode, then push “ENTER” to reach the program/step that you wish to edit.

To delete a recipe, use the same step above to enter the programming mode, then push “ENTER” to reach the program/step that you wish to erase. Enter “0” in speed and “0” in time in all steps.

To run a programmed recipe.

Push → **PROG**

Enter the Program number. → **1 2 3 4 5**
6 7 8 9 0

Push → **ENTER**

Push → 
START

After the ENTER key has been pushed, the data in step 1 will be displayed along with the program number.

After the last program step has been executed, the mixer will slow to minimum speed and shut off.

The mixer can be stopped at any time during a recipe by using the “PAUSE” button, the mixer will slow to stop and the recipe will not be lost. To continue on with the same recipe, push “START”.

Fixed Mode

Fixed mode is basically designed for users who operate the same recipes over and over again without frequent updating.

The maximum numbers of programs available in fixed mode is reduced from 25 to 10.

Fixed mode is a purely executional mode, its not possible to adjust the speed or time while in this mode.

The mixer will only run recipes that are programmed.

The advantage to this mode is that no one can “cheat” the programmed recipe.

The only applicable keys are START, STOP, PAUSE, BOWL LIFT, emergency stop and numeric keys.

To enter "FIXED MODE"

Push



PROG

"HOLD FOR 3 SECONDS"

Push "99"



1 2 3 4 5
6 7 8 9 0

Push



ENTER

Push "1 2 3 4"

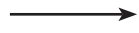

1 2 3 4 5
6 7 8 9 0

Push

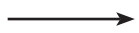

ENTER

1

Push the program number.



1 2 3 4 5
6 7 8 9 0

Push



START

To exit "FIXED MODE"

Push



PROG

"HOLD FOR 3 SECONDS"

Push "1 2 3 4"



1 2 3 4 5
6 7 8 9 0

Push



ENTER

Control Data for Program 26

Program 26 contains the control data required by the computer to operate. This data differs from model to model.

To access Program 26.

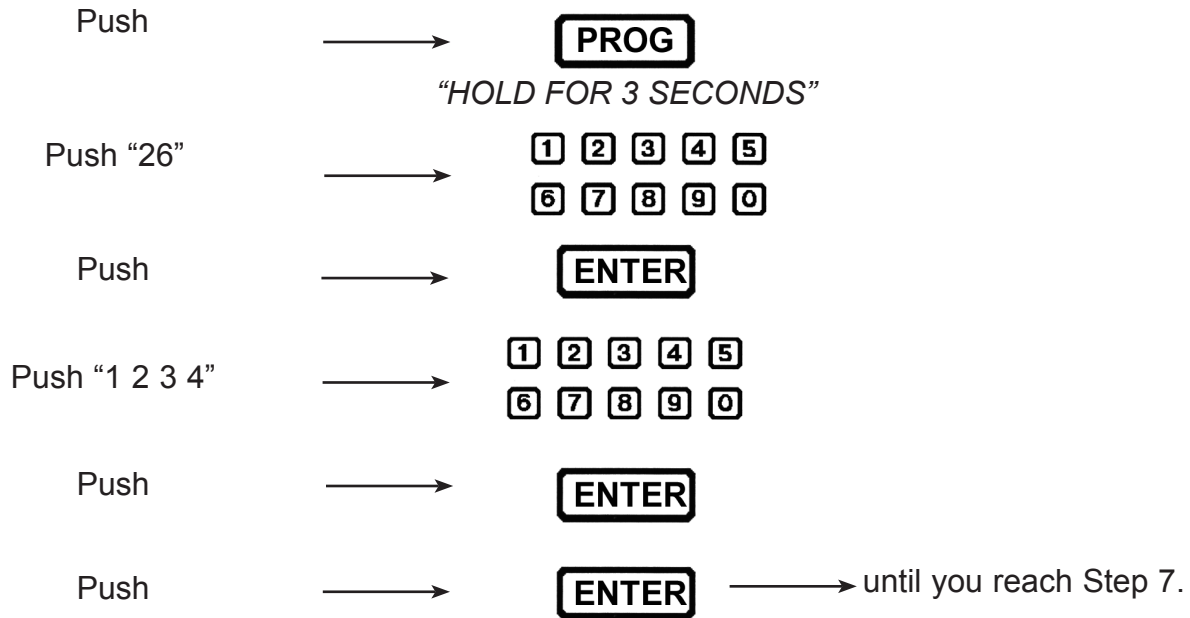

Enter the value on the following chart that matches the mixer model. Repeat for step 8 and 9.

<u>Step 7</u>		<u>Step 8</u>		<u>Step 9</u>	
Mixer Model	Value	Mode	Value	Mixer Model	Value
W30	30	"RPM" MODE	:00	W30	369
W40	40	(Speeds RPM)		W40	390
W60	60	OR		W60	375
W80	80	"SPEED MODE"	:02	W80	422
W100	100	(Speeds 1-4)		W100	422
W150	150			W150	422
Cinnabon 40	401			Krispy Kreme	425
Cinnabon 60	601			Cinnabon 40	737
				Cinnabon 60	660

Push → **ENTER**

Push → **PROG**

In the electronics fail.

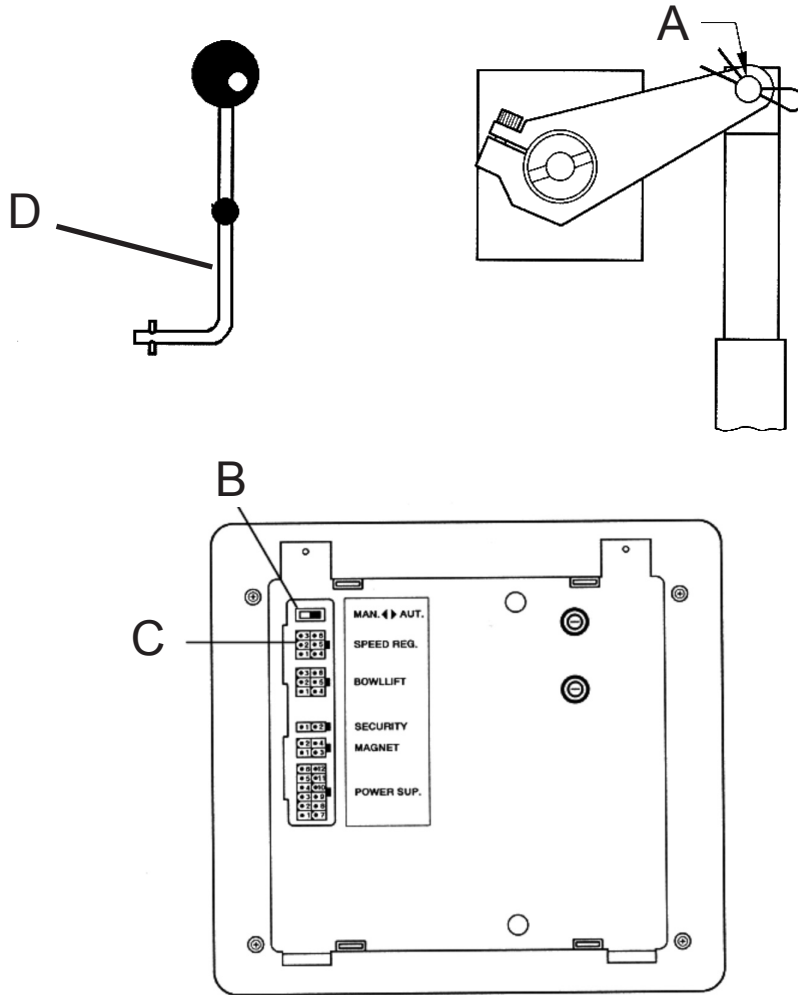

It is possible to bypass the control system if the electronics fail.

Please note, when the system is bypassed, the safety devices do not operate. Extreme care should be taken when operating the mixer.

1. Switch off the main power.
2. Open the top lid, flip the dip switch (B) on the back of the computer control from "Auto" to "Manual".(NOTE: The front L.E.D. lights will not display in "Manual" mode)
3. Disconnect the "Speed Reg" Harness(C).
4. Disconnect the servo motor by removing the cotter pin (A) the the clevis pin.
5. Remove the round black plug button on the right side of the mixer, and insert the auxillary speed lever (D) into the slotted shaft.
6. Close the lid, turn on the power.
7. Only 2 buttons will function, the START key and emergency stop button. Start the mixer and use the auxillary lever to adjust the speed.

Error Codes

A error in the mixer will trigger an ERROR code in the time display. See the chart below for an explanation of error codes and the procedure for correcting them.

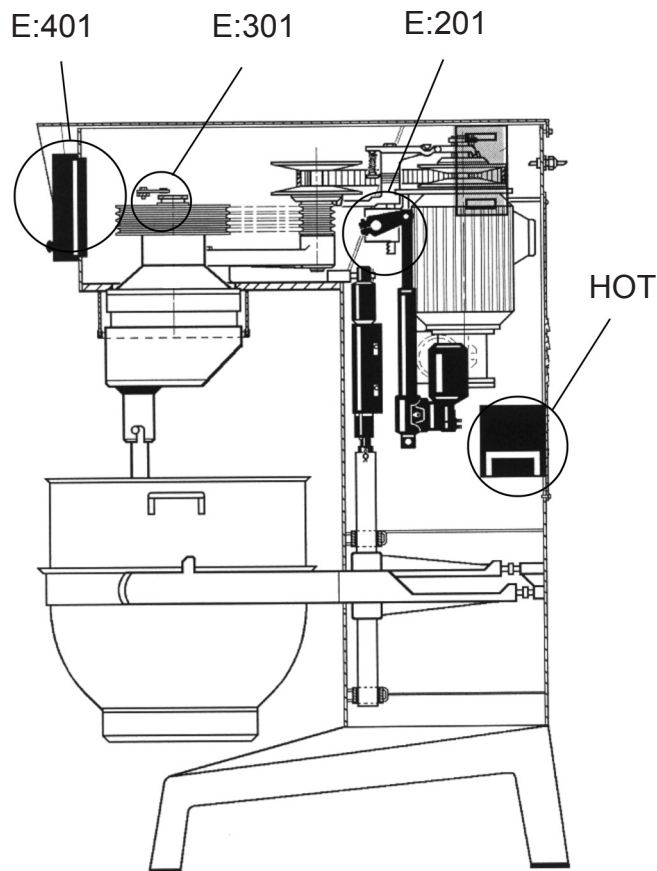

E:201 The servo motor block actuator (B) did not contact the minimum speed microswitch (A) after the stop button was pushed or the programmed recipe completed.

The computer is programmed to slow the mixer down to low speed before shutting off. It will not do this unless the microswitch is contacted by the block mounted on the speed adjustment shaft.

To correct this error:

- 1) Check the microswitch (A) to see if it is working by manually pushing it, when pushed, the "MIN" light should energize on the control panel. If it does not, the microswitch is faulty.
- 2) The actuator (B) is not contacting the switch, adjust the switch up by loosening the screws (C).
- 3) The servo motor is not moving at all. check the fuses in the rear of the control , if blown, replace ,if not blown ,check the voltage (31 VDC) at the servo motor while the mixer is running. If voltage is present, the servo is faulty.

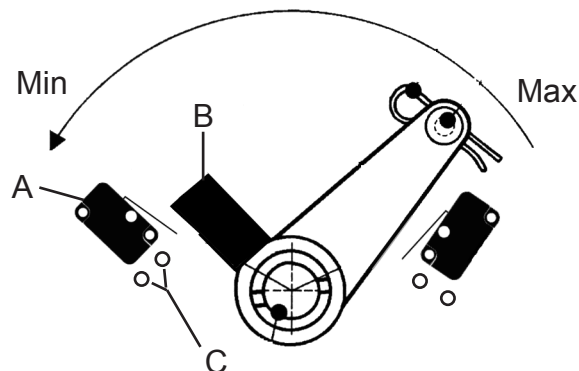

E:301 There is no signal from the speed pickup (hall effect sensor).

To correct this error:

- 1) Check that the sensor (D) is centered directly above the track of the 3 magnets (F) on the pulley and the gap between the sensor and magnets is 1/16". If not, bend and / or move the bracket (I) holding the sensor.
- 2) Inspect the three wires between the sensor and the plug. Replace the sensor if wires are broken.

Side View

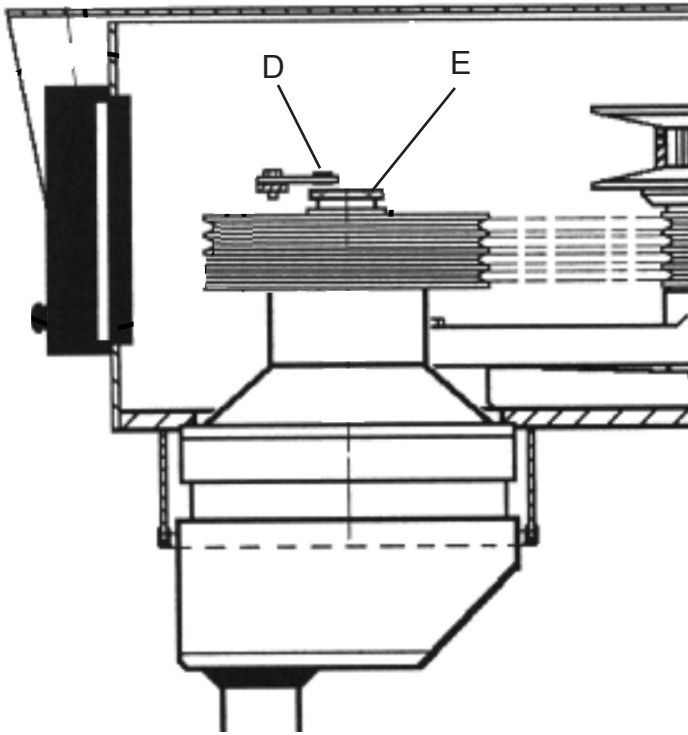

Top View

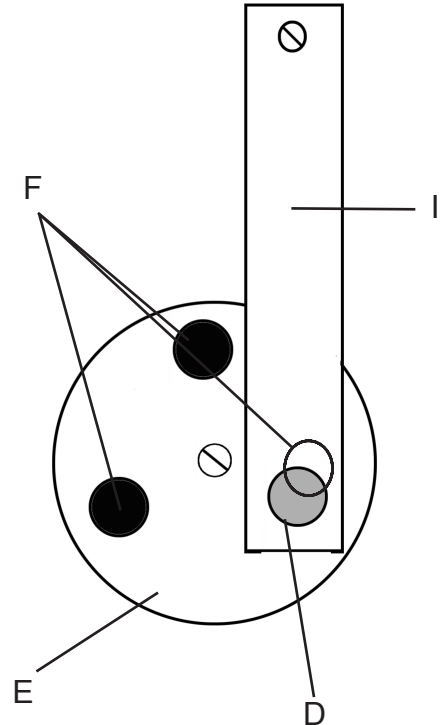

HOT The thermal overload has tripped because of excessive amp draw or heat. The overload will automatically reset after it has cooled. This function is to protect the mixer.

To correct this error:

- 1) Have a service technician inspect all wiring, contactor and overload for faults.
- 2) Monitor the amp draw while the unit is operating. If excessive, the drive motor may be failing.

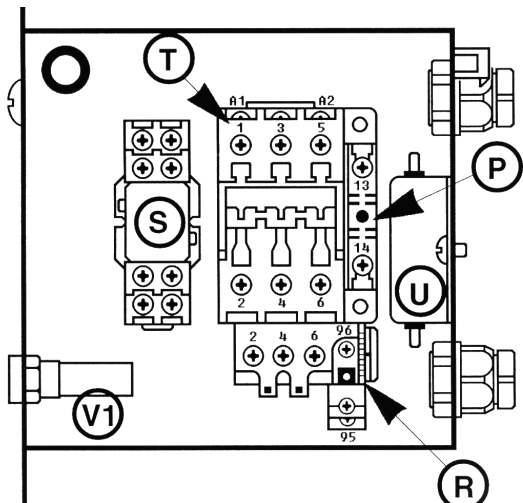

Sockets in power supply.

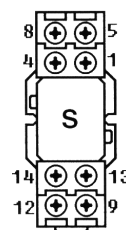

- M Transformer
- N..... Diode 1N4003
- P Auxiliary switch
- R..... Thermal overload relay
- S Relay 24vdc
- T Relay for motor
- U Filter
- V1 ... Fuse 1.5 Amp
- W Rectifier
- Y Motor brake

E:4:01 The values in program 26 steps 7, 8 and 9 are missing or incorrect.

To correct this error:

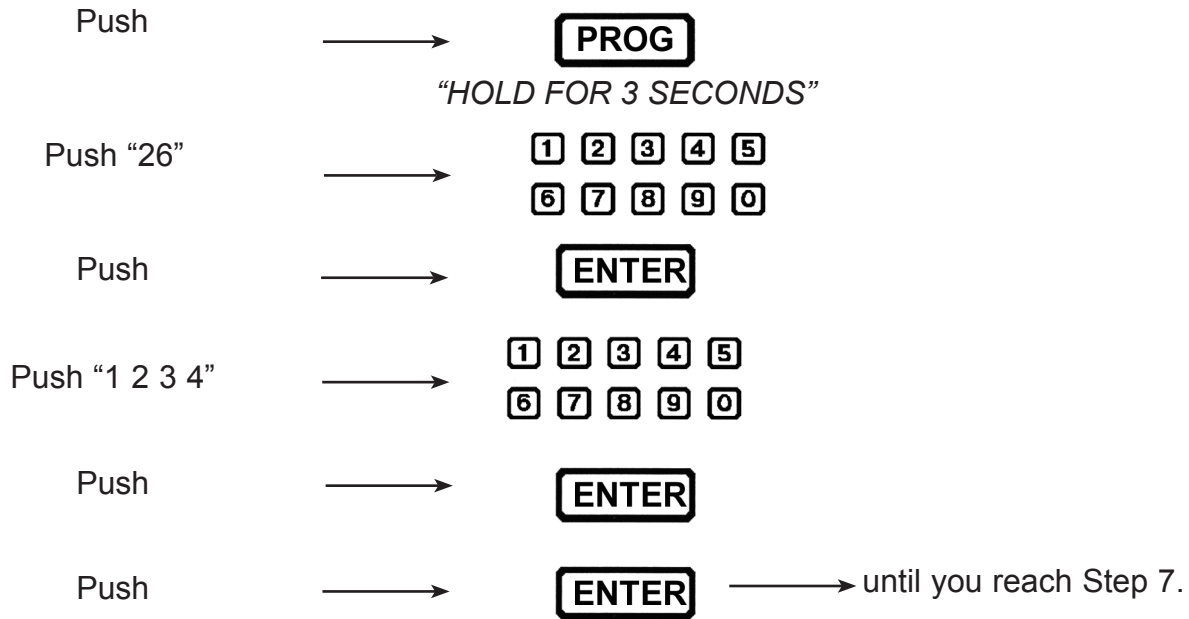

Enter the value on the following chart that matches the mixer model. Repeat for step 8 and 9.

<u>Step 7</u>		<u>Step 8</u>		<u>Step 9</u>	
<u>Mixer Model</u>	<u>Value</u>	<u>Mode</u>	<u>Value</u>	<u>Mixer Model</u>	<u>Value</u>
W30	30	“RPM” MODE	:00	W30	369
W40	40	(Speeds RPM)		W40	390
W60	60	OR		W60	375
W80	80	“SPEED MODE”	:02	W80	422
W100	100	(Speeds 1-4)		W100	422
W150	150			W150	422
Cinnabon 40	401			Krispy Kreme	425
Cinnabon 60	601			Cinnabon 40	737
				Cinnabon 60	660

Push → **ENTER**

Push → **PROG**

OVERLOAD light: When activated, mixer will lower speed 20% until it can maintain a steady speed.

1. Too much dough in the bowl (overloading) or speed set to high. Lower dough amount and speed.
2. V-belts slipping, tighten belts or replace as needed.
3. Drive pin in motor pulley sheared, replace.
4. Hall effect sensor out of adjustment or magnet disc loose. (See E:301)

MAINTENANCE AND ADJUSTMENTS

Fuse data and component location

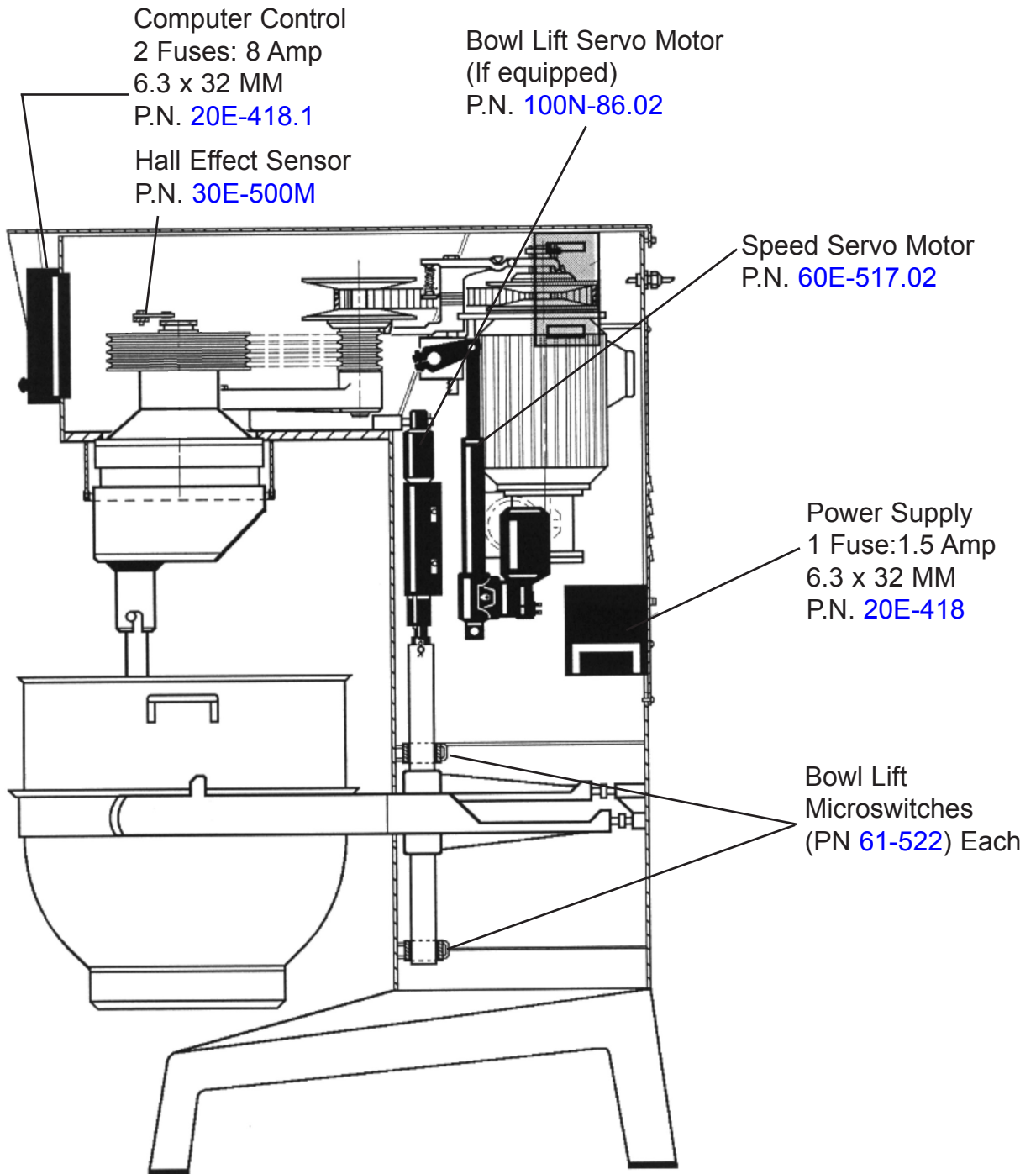

Bowl adjustments

Models W30, W40, W40P, W60, W60P

ADJUSTMENT OF BOWL CLAMPING:

The bowl arms must be raised to normal working position. Loosen the counter nuts **(1)** and remove the cotterpins **(2)**. Turn the bolts **(3)** until correct fixing of the bowl is achieved. By turning the bolts **out** of the extension tube the fixing is increased. Start by turning one of the bolts half a revolution.

The arms should be adjusted so that the bowl cannot be moved in any direction whatsoever.

ADJUSTMENT OF BOWL CENTERING:

Loosen the counter nuts **(1)** and remove the cotterpins **(2)**. Turn the bolts **(3)** until the bowl is in the centre of the mixer. In order not to alter the fixing of the bowl, one of the bolts must be turned **out** of the extension tube and the other **into** the extension tube. Use the flat beater to check that the bowl is correctly centered and turn the planetary head with your hand before the voltage is connected.

fig.6 Adjustment of bowl fixing and bowl centering:

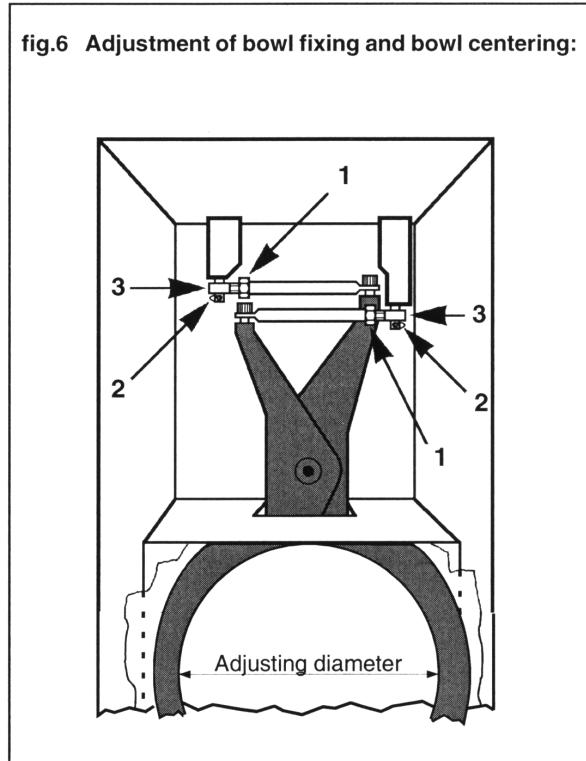

ADJUSTMENT OF BOWL HEIGHT:

The distance **(X)** is measured from the bottom side of the bayonet hole to the surface on the bowl arms on which the bowl rests **(fig.7a)**. The bowl arms must be lifted to normal working position.

W30 = 6 3/8"
 (X): W40 = 6 3/8"
 W60 = 7"

Lower the bowl arms down on a wooden block so that the weight of the bowl arms are not loading the lifting system. Loosen the counter nut **(1)**, **(fig.7b)**. Take out the cutter pin **(2)**. Take out the lifting rod **(3)**. The lifting bolt **(4)** is now loose and can be turned out or into the lifting nut **(5)**, until the correct height of the bowl arms has been reached.

fig.7b Adjustment of bowl height:

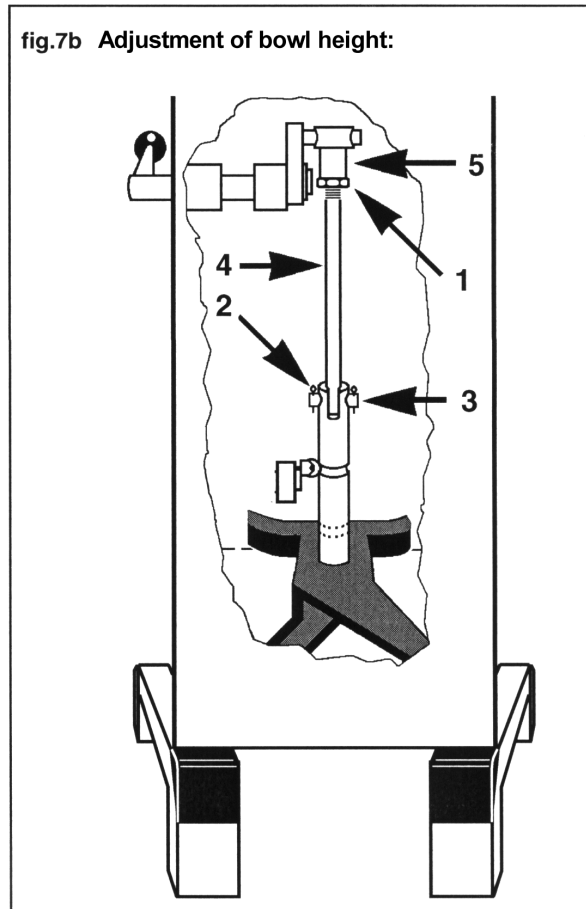
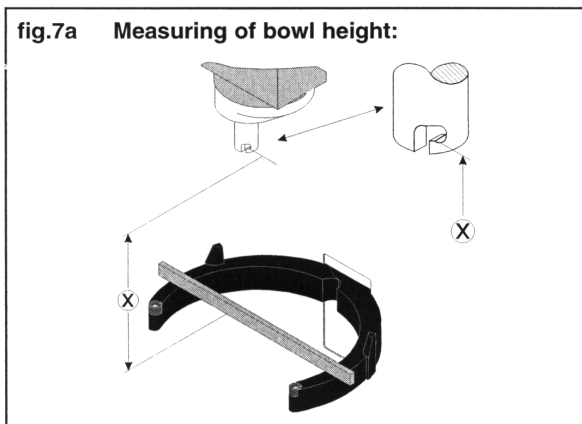

fig.7a Measuring of bowl height:



Bowl adjustments Models W80, W100, W150N

ADJUSTMENT OF BOWL CENTERING:

First find the present bowl centering: mount the beater and the bowl, then raise the bowl arms up to normal working position. With your hand turn the beater, and then measure the distance between beater and bowl edge. By removing the rear covering, the bowl arm guide plate is now accessible **(E)**. Loosen the screws **(D)** and move the bowl arm guide plate in the required direction. Again turn the beater and measure the distance between beater and bowl. When the bowl has been centred, fasten the bowl arm guide plate in the new position and screw on the rear covering.

ADJUSTMENT OF BOWL FIXING:

The bowl arms must be raised to normal working position.

The arms should be adjusted so that the bowl cannot be moved in any direction whatsoever.

In case the bowl fastening is too loose, remove the lock ring **(B)** and draw the bearing **(A)** from the shaft **(C)**. The bearing should be turned 180° and be mounted on the shaft again. It might be necessary to turn both bearings. At last check the bowl centering and if necessary, adjust.

ADJUSTMENT OF BOWL HEIGHT:

The distance **(X)** is measured from the bottom side of the bayonet hole to the surface on the bowl arms on which the bowl rests **(fig.7a)**. The bowl arms must be lifted to normal working position.

$$\begin{aligned} W80 &= 9 \frac{1}{8}'' \\ \text{(X): } W100 &= 11 \frac{5}{8}'' \\ W150 &= 11 \frac{7}{8}'' \end{aligned}$$

The upper and lower position of the bowl is determined by micro switch **(1)** and **(2)**, **(fig. 7b)**. The two mechanical stops consisting of the bolts **(3)** and **(4)** are adjusted so that they will be hit approx. 1 mm after the micro switch, in case the micro switch should fail. The upper position of the bowl arms is adjusted by bending the spring arm of the micro switch **(2)** either forwards or backwards; it is of utmost importance that the stop screw **(3)** is re-adjusted afterwards. In the same way the lower position is adjusted by bending the spring arm of the micro switch **(2)**. **NB:** The spring arm must not be bent so far backwards that the bowl arms do not hit it. Thereafter the mechanical stop **(4)** is adjusted.

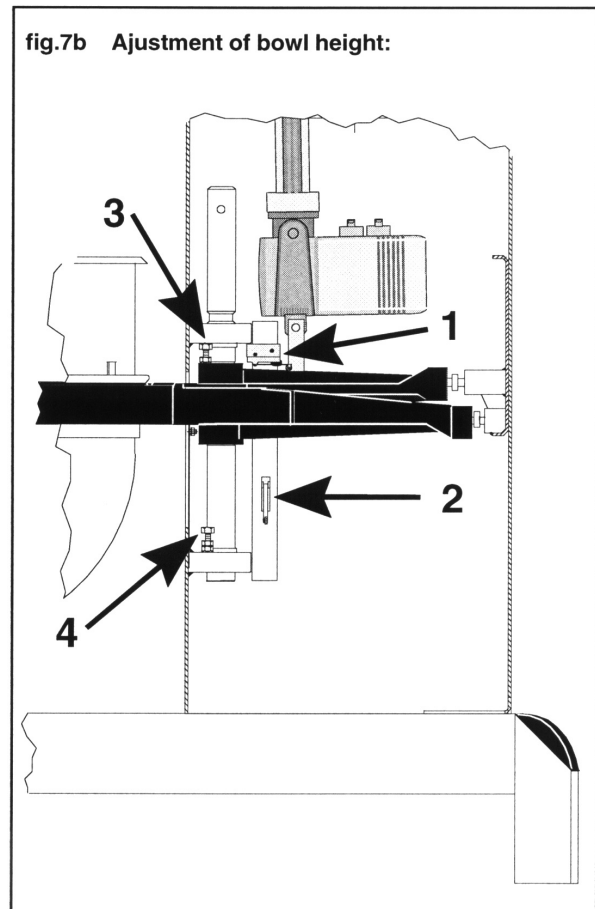
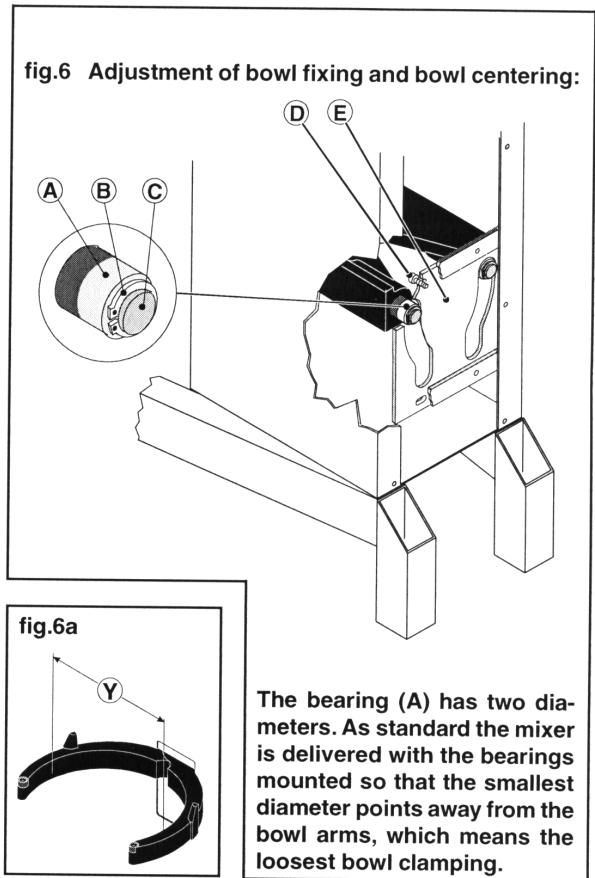

Lubrication

On normal use of the mixer the infinitely variable gear must be lubricated approx. once a year. On very frequent use of the mixer and on frequent use without change of speed the lubricating intervals are shorter.

Fig. 1. Start the mixer and increase the speed to approx. 50%. Stop the mixer, and open the lid on the top of the mixer by removing the 4 screws (A). At the top of the pulley set shafts there is a grease nipple, one on each pulley set. Press grease through the grease nipples until the grease gun feels hard to press or until grease comes out between the shaft and the pulleys.

Close the lid and remember to insert the 4 screws (A) which hold the lid.

The mixer must not be started until the screws which hold the lid are inserted.

Start the mixer and set the speed back to low speed.

Stop the mixer and fill the grease gun with new grease so that it is ready for next time.

Fig. 2. Approx. once a year the movable parts of the bowl arms and the shaft must be lubricated with **white lithium grease**.

Remove the screws (B) from the mixer's rear plate and remove the rear plate. Pour a little oil on the movable parts, especially the 2 bearings for the shaft of the bowl arms, and move the bowl arms up and down a couple of times so that the oil can spread.

Fig. 2

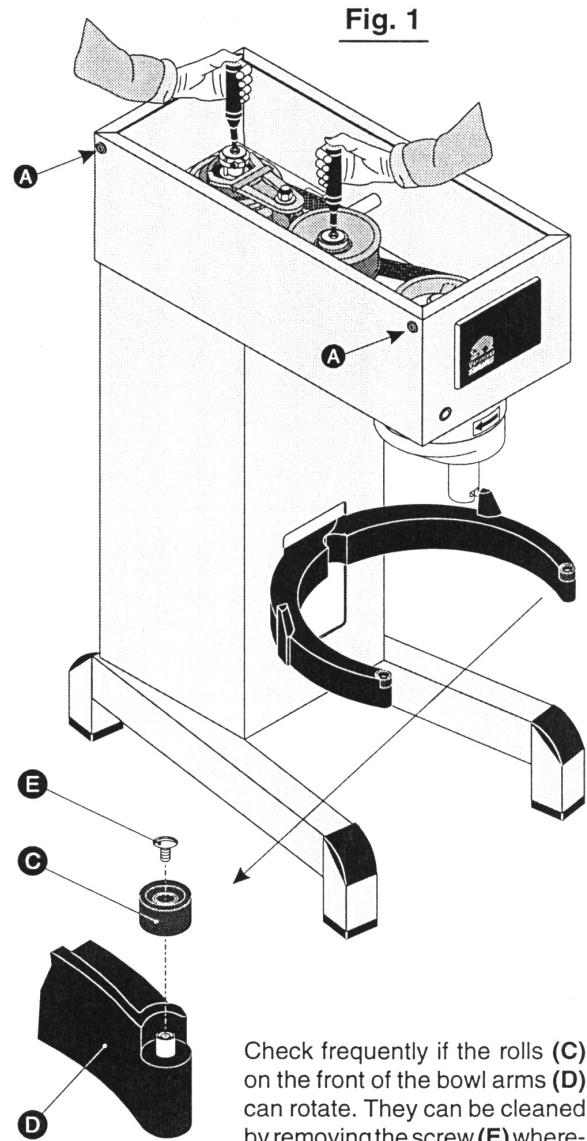
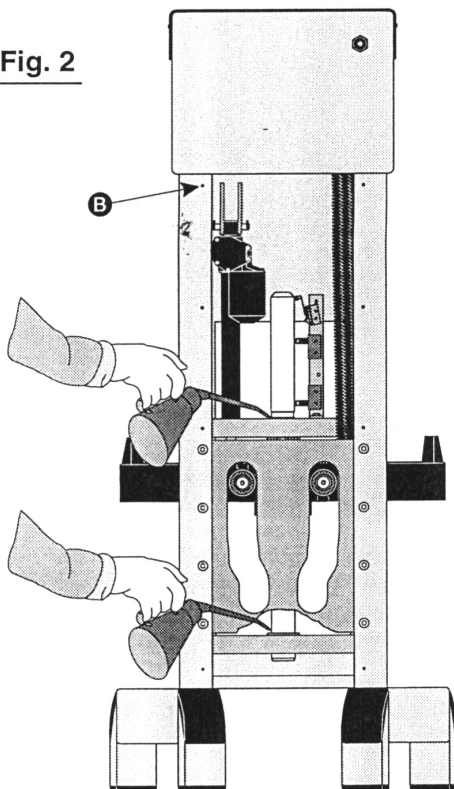

Check frequently if the rolls (C) on the front of the bowl arms (D) can rotate. They can be cleaned by removing the screw (E) whereafter the roll can be pulled up. Wash the shaft and the roll in lukewarm water.

GREASE TYPES

Grease for the pulley set shafts:

White Lithium Grease (IE Lubriplate)

On repair of the planetary head, the toothed wheel and the toothed rim shall be lubricated with the grease type:

Nye Fluorocarbon Gel 868VH

Order from authorized service agent
Part number: WHITE GREASE

Belt adjustments

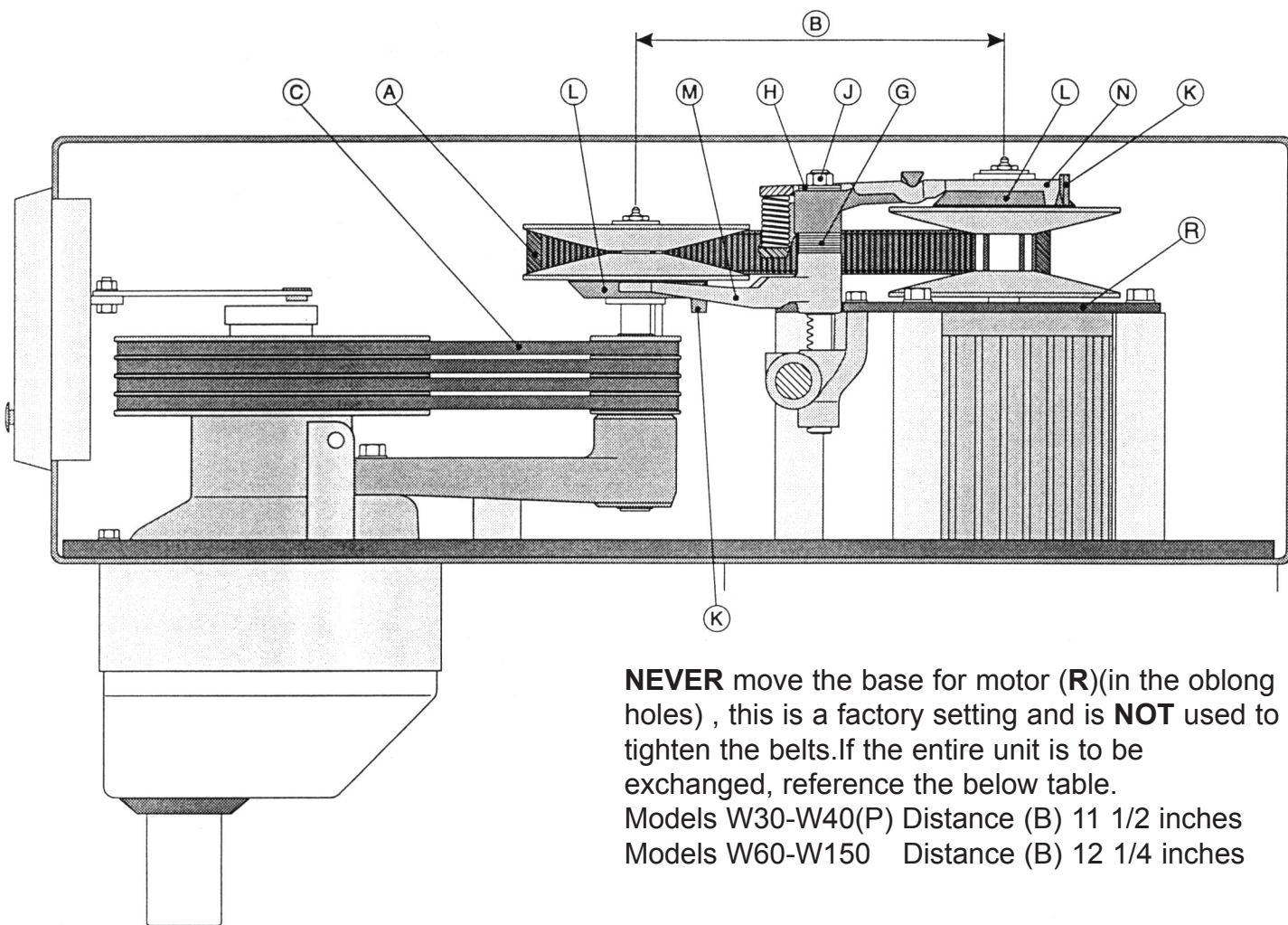

NEVER move the base for motor (R) (in the oblong holes), this is a factory setting and is **NOT** used to tighten the belts. If the entire unit is to be exchanged, reference the below table.

Models W30-W40(P) Distance (B) 11 1/2 inches

Models W60-W150 Distance (B) 12 1/4 inches

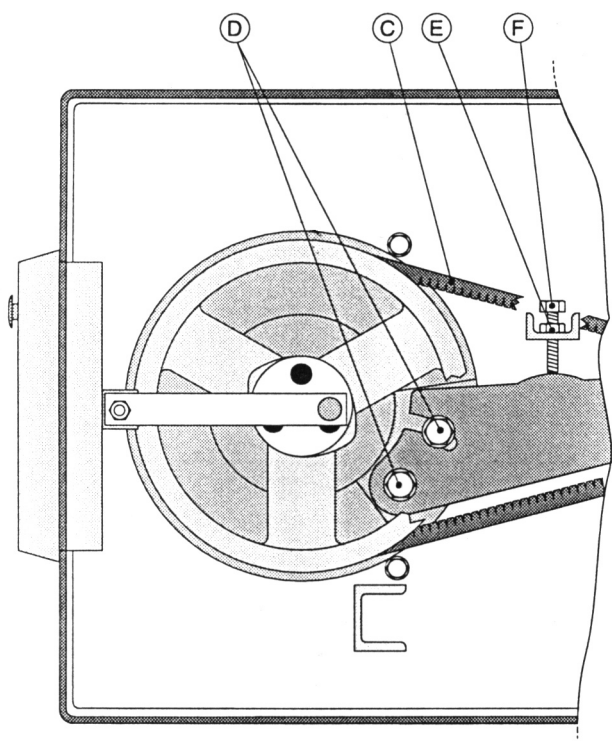

1. Start by tightening the V-belts (C).
 - A) Loosen the bolts (D) and the jam nut (E).
 - B) Tighten the bolt (F) until the V-belts are tight, tighten the the 2 bolts (D).
 - C) Back bolt (F) out away from arm.
DO NOT LEAVE AGAINST ARM.
2. If the main vari belt (A) appears loose when the unit is running.
 - A) Remove nut (J) and washers (H).
 - B) Pry upper spring fork assembly (N) off of shaft.
 - C) Remove 1 or 2 washers from (G).
 - D) Reinstall spring fork assembly (N), washers (H) and nut. (J). DO NOT TIGHTEN NUT.
 - E) Start the mixer and tighten nut (J) until snug.
3. Now turn to Page 20 and follow the instructions "Adjustment of low (min) and high (max) speed microswitches".

Belt Exchange

1. Loosen Bolt (J) and remove washers (H).
2. Remove cotterpin (T) and dowel pin (E) from servo linkage.
3. Remove vari drive belt (A) from pulleys.
4. Remove Hall Effect sensor (X) from the rear of the computer.
5. Loosen bolts (D) and remove the front v-belts (C) by tilting the center pulley assembly (L) forward and rolling the belts (C) off the front pulley one at a time. The belts can now be threaded between the lower fork (M) and the lower movable pulley.

Installing and tightening of V-belts

6. Install the V-belts (C) on the center pulley assembly and front pulley.
7. Tighten the two bolts (D).
8. Tighten the bolt **(F)** until the V-belts are tight, then tighten the the 2 bolts **(D)**. Back bolt **(F)** out away from arm. DO NOT LEAVE AGAINST ARM.
9. Install the Hall Effect sensor (X) onto the computer and align.
(See page 11)
10. Measure the distance (B) to insure it is within tolerance...
Models W30-W40(P) Distance (B) 11 1/2 inches
Models W60-W150 Distance (B) 12 1/4 inches
11. If the measurement is out of spec, the motor assembly should be moved by loosening the four bolts (P) on the motor mount plate, sliding the motor until it is within the proper distance, and retighten bolts (P).
12. Install the vari drive belt. **(A)**
13. Install fork assembly.
14. Install washers **(G)** and nut. **(J)** DO NOT TIGHTEN NUT.
15. Start the mixer and tighten nut. **(J)**
16. Follow the instructions on Page 20, "Adjustment of min and max speed microswitches".

Belt Exchange

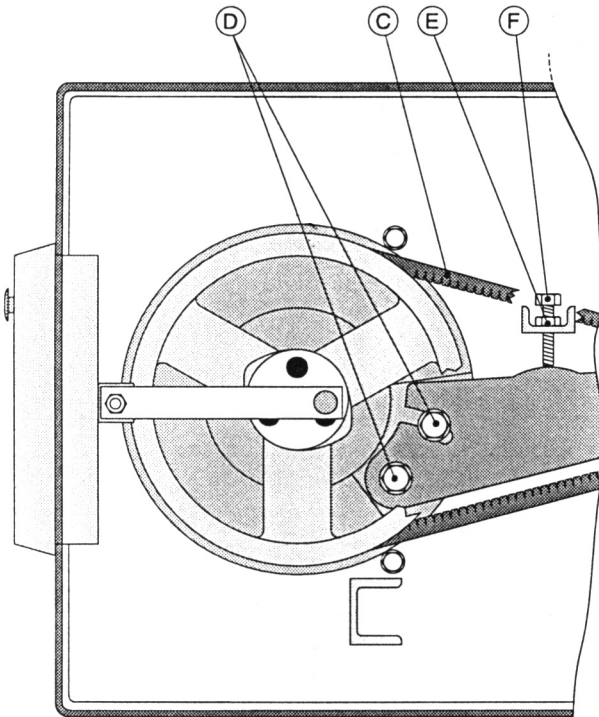
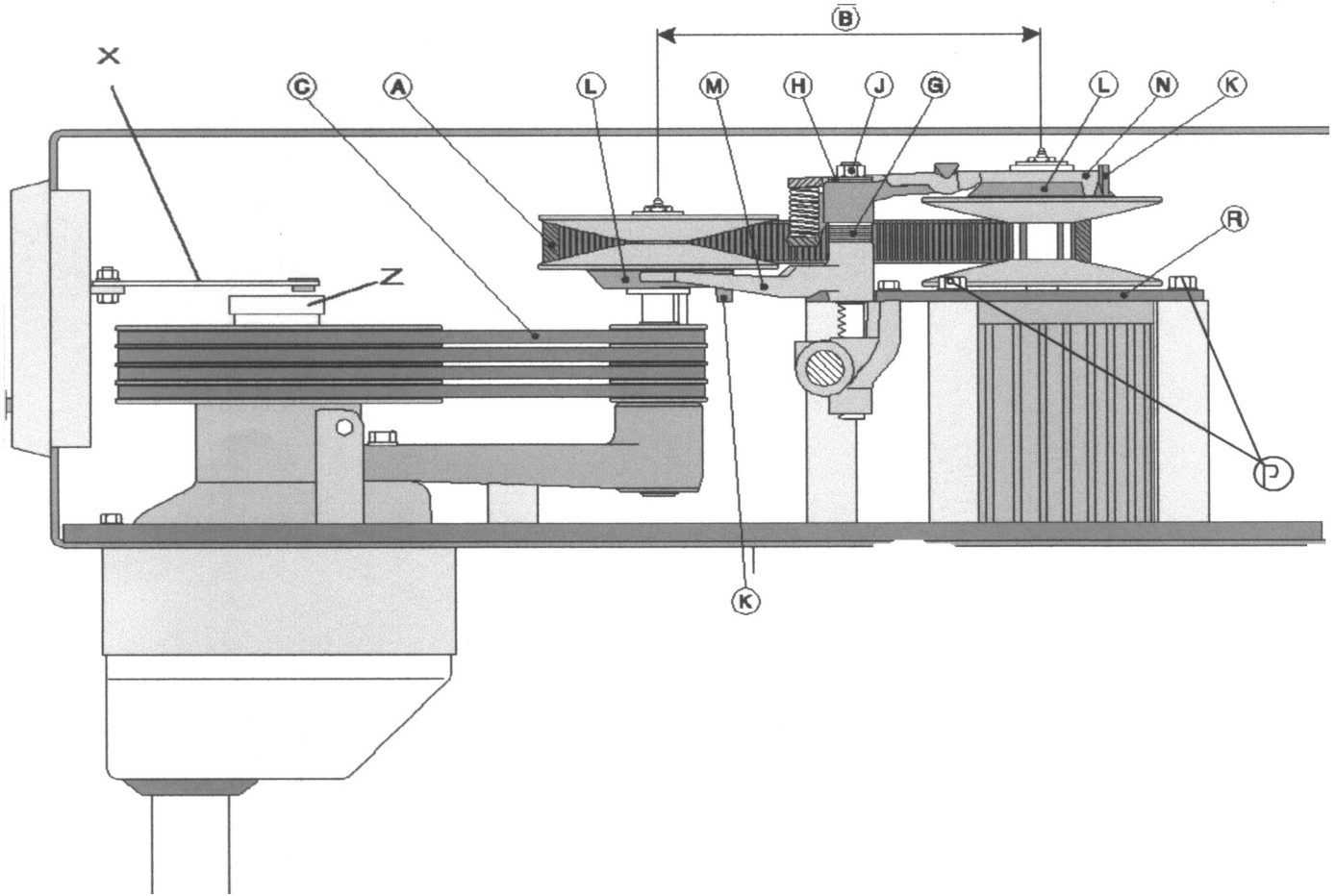

Adjustment of low and high speed microswitches.

- 1 PRIOR TO ANY ADJUSTMENT THE MIXER MUST BE AT MINIMUM SPEED,THE BOWL MUST BE IN "UP" POSITION AND THE BOWL SCREEN IF EQUIPPED,MUST BE CLOSED.
- 2 PRESS THE EMERGENCY STOP SWITCH.
- 3 THE CABLE TO THE SERVO MOTOR MUST BE DISCONNECTED AT THE REAR OF THE CONTROL BOX, THE SOCKET IS MARKED "SPEED REG".
- 4 THE SLIDE SWITCH ON THE REAR OF THE CONTROL BOX MUST BE IN THE "MAN" POSITION.
- 5 THE ARM (U) IS RELEASED FROM THE SERVO MOTOR SHAFT BY REMOVING THE COTTERPIN (E) AND THE PIN (T).THE ARM (U) MUST NOT BE LOOSENED FROM THE SHAFT(V).
- 6 THE MANUAL SPEED SELECTOR LEVER INCLUDED WITH THE MIXER,IS PLACED IN THE SHAFT (V) SO THAT IT POINTS UPWARDS AND FORWARDS.(REMOVE THE COVER FROM THE SIDE OF THE MIXER)
- 7 RELEASE THE EMERGENCY STOP SWITCH AND START THE MIXER,INCREASE THE SPEED WITH THE SELECTOR LEVER UNTIL THE DISTANCE (C) ON THE REAR PULLEY IS 0-1/8". *HIGH SPEED*
- 8 STOP THE MIXER BY PRESSING THE EMERGENCY STOP SWITCH ON THE CONTROL BOX.
- 9 ADJUST THE HIGH SPEED MICROSWITCH SO THAT IT IS ACTIVATED BY THE BUSHING(X).TIGHTEN JAM NUT ON MICROSWITCH. *"MAX LIGHT SHOULD BE ON"*
- 10 RELEASE THE EMERGENCY STOP SWITCH AND RESTART THE MIXER,WITH THE MANUAL SPEED SELECTOR LEVER ,LOWER THE SPEED UNTIL THE DISTANCE (C) IS 0-1/8" ON THE FRONT PULLEY SET. *"LOW SPEED"*
- 11 STOP THE MIXER BY PRESSING THE EMERGENCY STOP SWITCH ON THE CONTROL BOX.
- 12 ADJUST THE LOW SPEED MICROSWITCH SO THAT IT IS ACTIVATED BY THE BUSHING(X).TIGHTEN JAM NUT ON MICROSWITCH. *"MIN LIGHT SHOULD BE ON"*
- 13 RECONNECT THE CABLE FROM THE SERVO MOTOR TO THE CONTROL BOX. THE SOCKET IS MARKED "SPEED REG".
- 14 MOVE THE SWITCH ON THE REAR OF THE CONTROL BOX TO "AUTO".
- 15 REMOVE THE SPEED SELECTOR (F) AND REPLACE THE COVER ON THE SIDE OF THE MIXER.
- 16 MOUNT THE PIN (T) AND THE COTTERPIN (E) WHICH CONNECTS THE ARM (U) TO THE SERVO MOTOR SHAFT.
BE AWARE THAT THE SERVO MOTOR SHAFT MUST NOT TOUCH THE SHAFT (V) IN MINIMUM SPEED.
- 17 RELEASE THE EMERGENCY STOP SWITCH.
- 18 INSTALL THE TOP LID.

Adjustment of low and high speed microswitches.

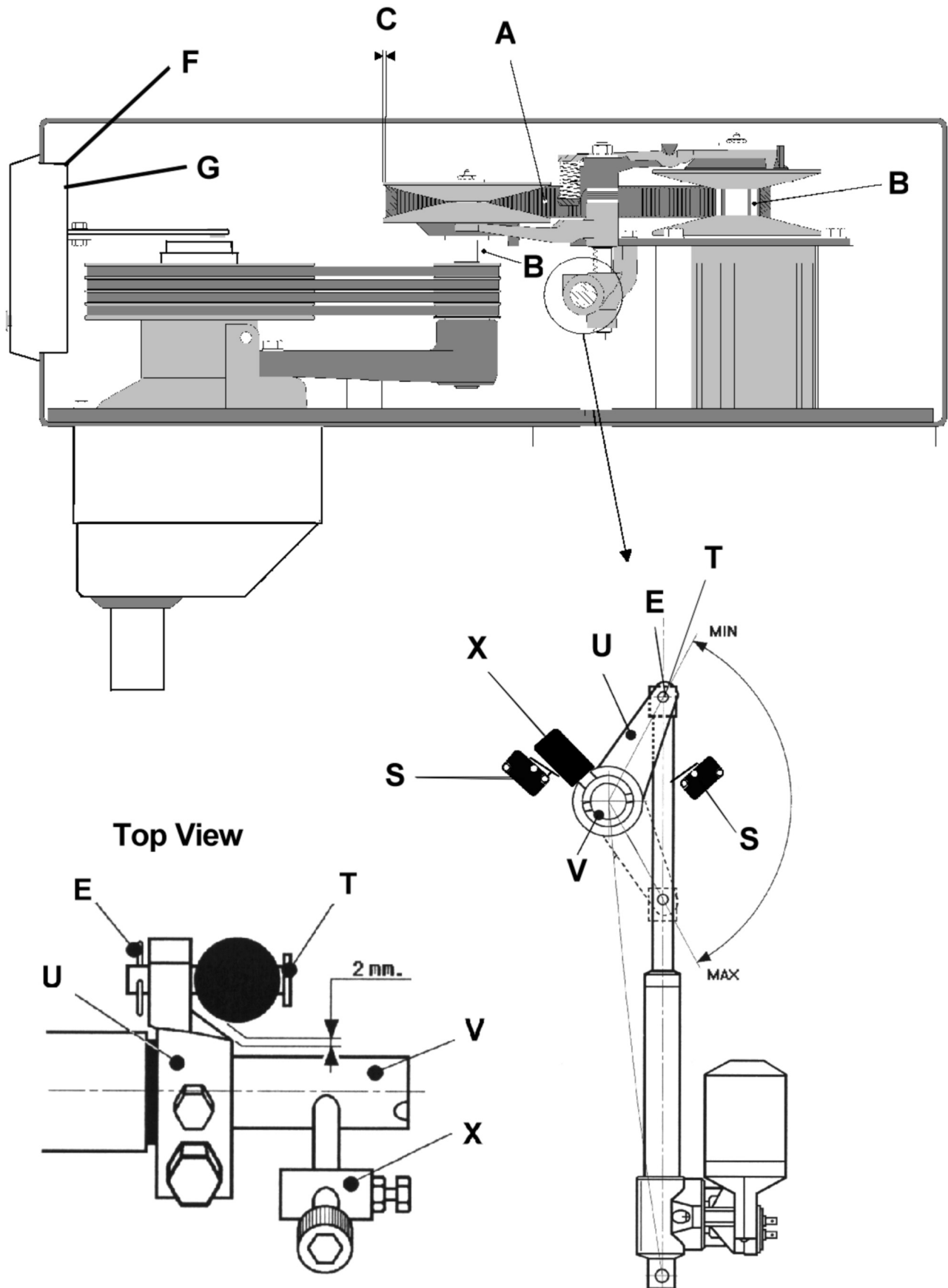

Speed Servo System

Figure Number	Description	W30, W40 , W40P	W80, W100 , W150
1.....	Sensor.....	30E-500M	30E-500M
2.....	Bolt M6.....	STA 5432.....	STA 5432
3.....	Magnets.....	30E-515M	30E-515M
4.....	Screw.....	STA 5011.....	STA 5011
5.....	Speed Microswitch.....	30E-507	30E-507
5A.....	Speed Micro w/roller.....	30E-508	30E-508
7.....	Shaft.....	30E-47M.....	60E-47M
8.....	Snap Ring.....	STA 3414.....	STA 3414
9.....	Bushing.....	20-310	20-310
10.....	Screw.....	STA 5636.....	STA 5636
11.....	Bolt.....	STA 5432.....	STA 5432
12.....	Nut.....	STA 5819.....	STA 5819
13.....	Servo Arm 12MM I.D.....	30E-543	60E-543
13.....	Servo Arm 1/2" I.D.....	30E-543	60E-543.1

ITEM
13

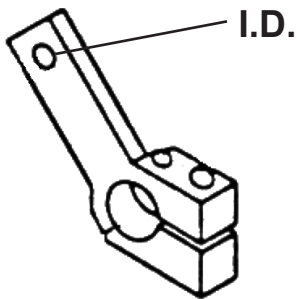

Measure I.D. of hole
OR O.D. of Pin to
determine correct
part number.

ITEM
18

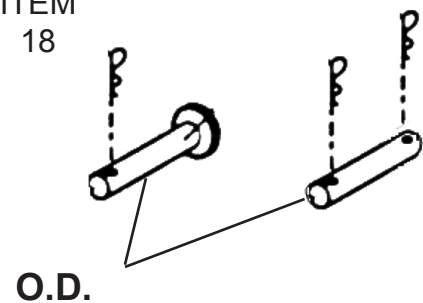

17.....	Plug Button.....	30E-47.12	30E-47.12
16.....	Speed Servo Motor.....	60E-517.02	60E-517.02
18.....	Servo Pin 12MM O.D.....	60E-70	60E-70
18.....	Servo Pin.1/2" O.D.....	60E-70.2	60E-70.2
19.....	Cotter Pin.....	STA 6205.....	STA 6205
20.....	Control Assembly.....	20E-604M	20E-604M
21.....	Emergency Stop.....	20E-615M	20E-615M
22.....	Retrofit Handle.....	20E-47.1M	20E-47.1M

Speed Servo System

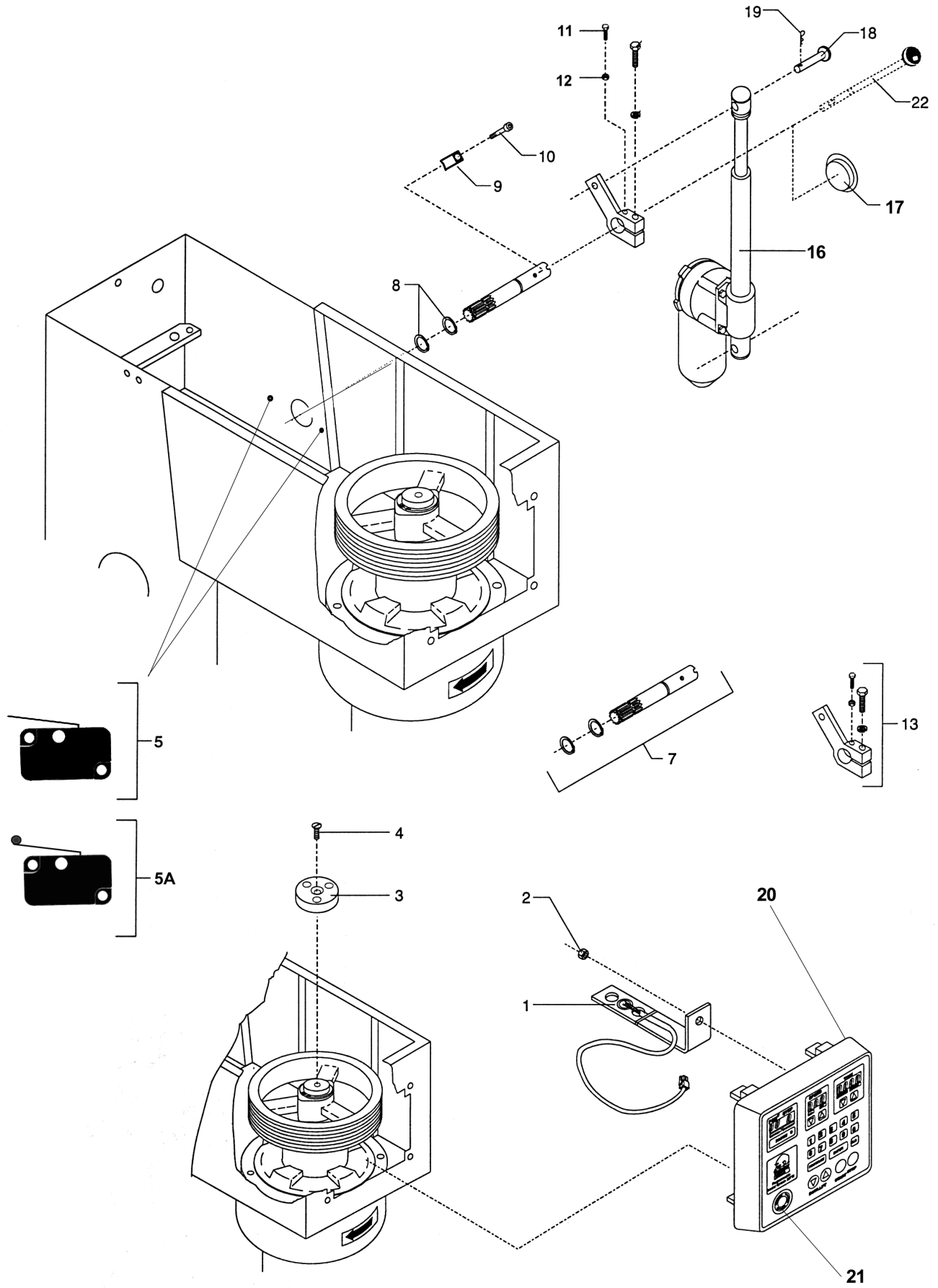

Power Supply

Figure Number	Description	All Models
1.....	Transformer.....	60E-430
2.....	Filter.....	20E-419
3.....	Relay 24VDC.....	140E-420
4.....	Fuse Holder.....	20E-416.1
5.....	Fuse.....	20E-418
6.....	Compression Fittings	STA 3000
7.....	Thermal Overload.....	20-88.24
8.....	Contactors	100-88.5
9.....	Auxilliary Switch.....	20-88.47
10.....	Grey Harness.....	60E-428
11.....	Computer Harness.....	60E-542.1

Power Supply

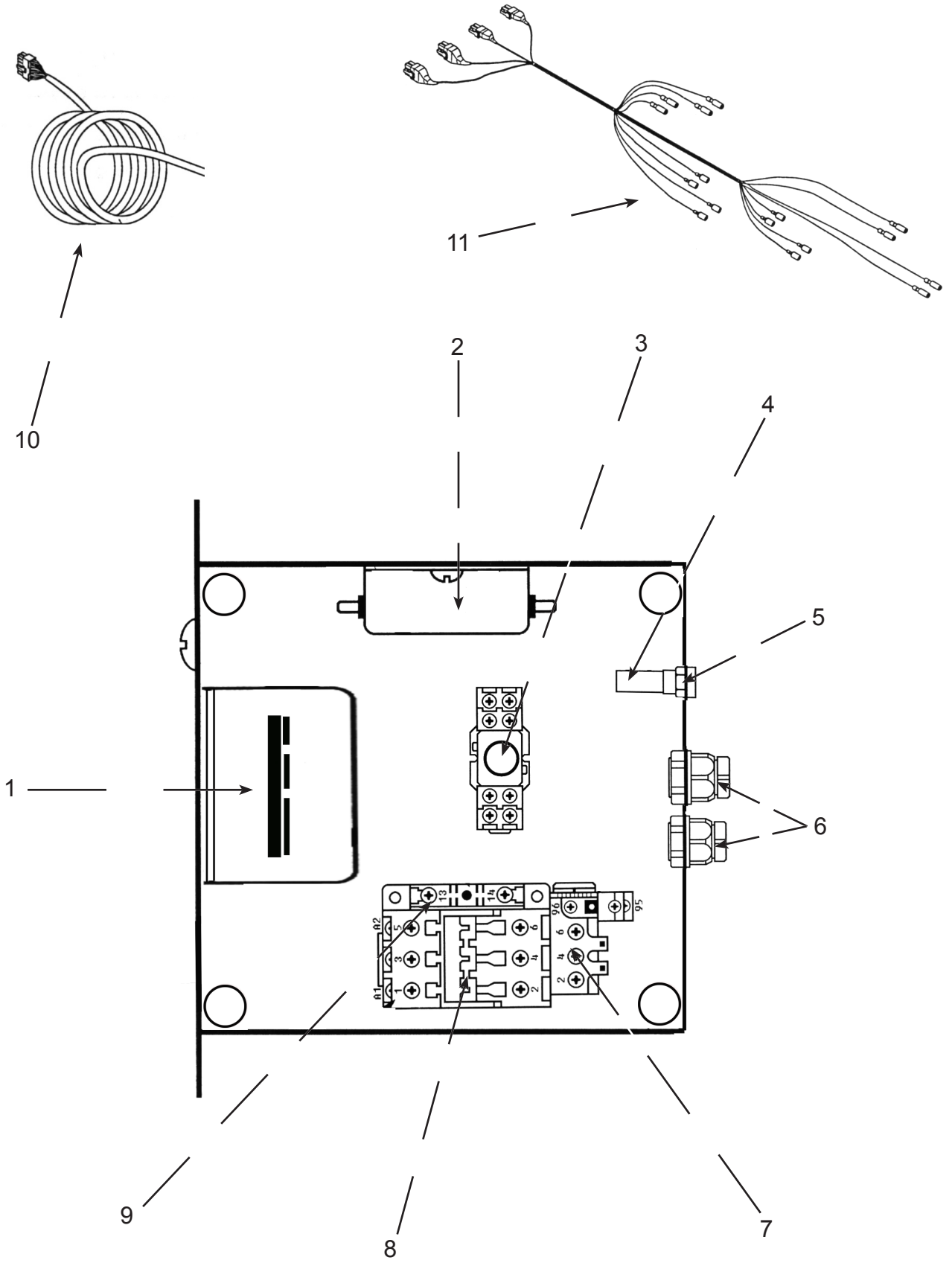

Manual Bowl Lift

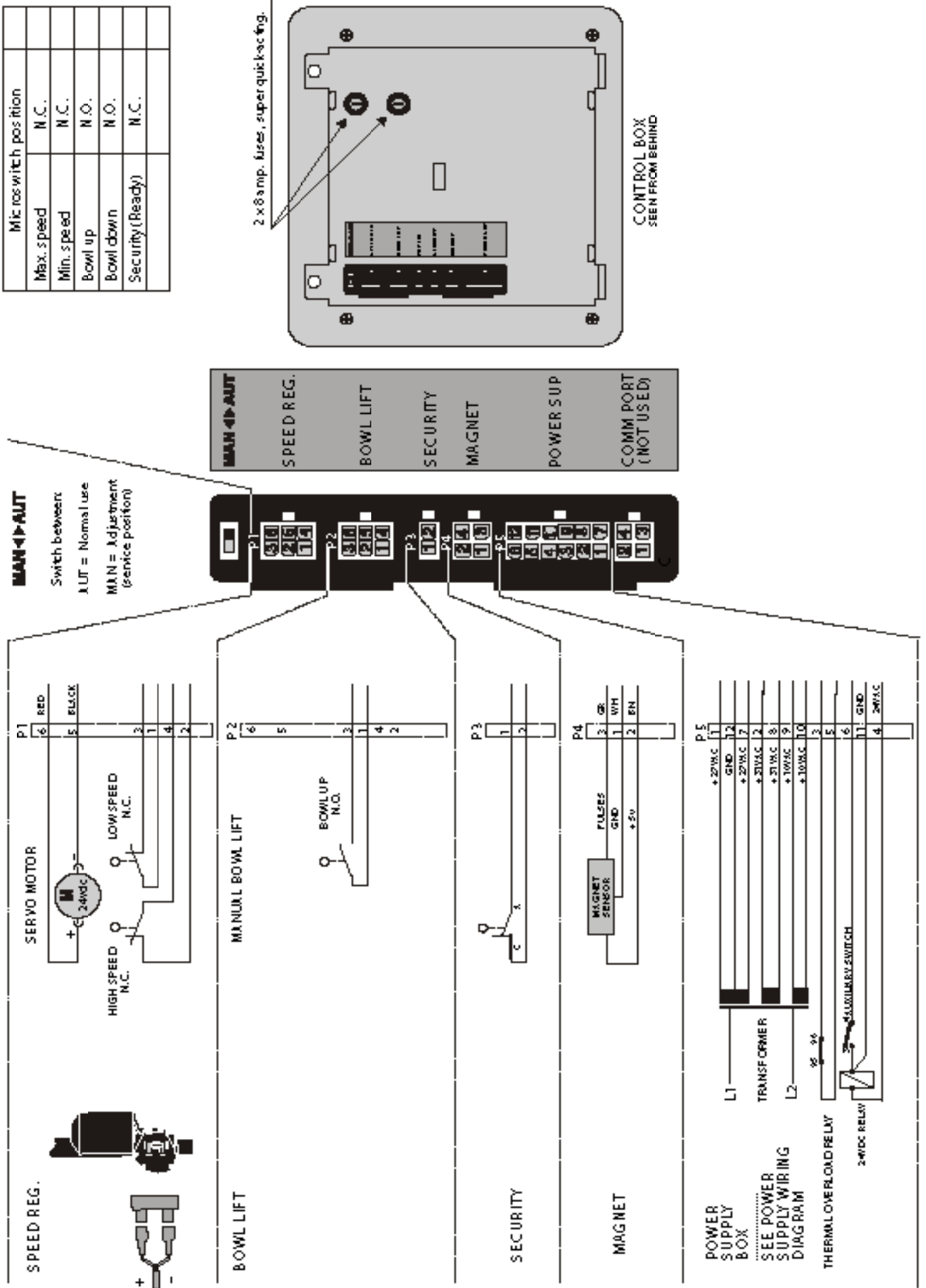

Micro switch position	
Max. speed	N.C.
Min. speed	N.C.
Bowl up	N.O.
Bowl down	N.O.
Security (Ready)	N.C.

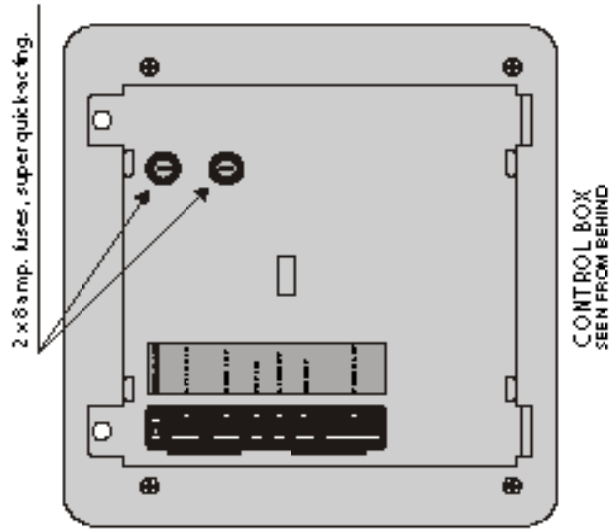

Power Bowl Lift

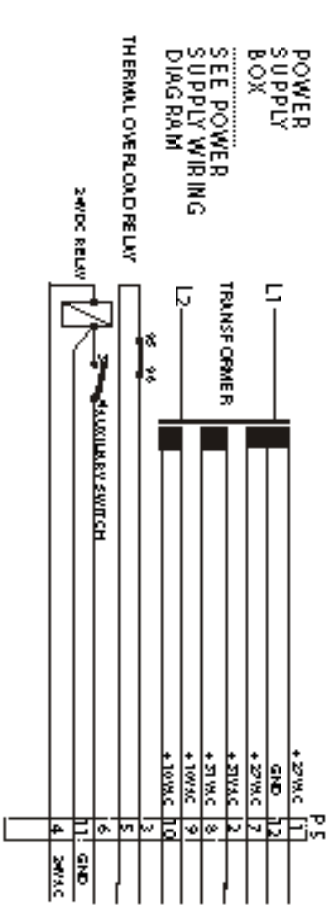
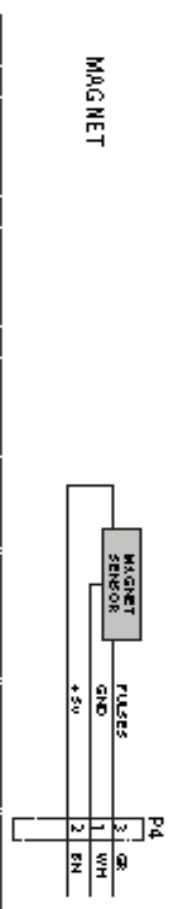
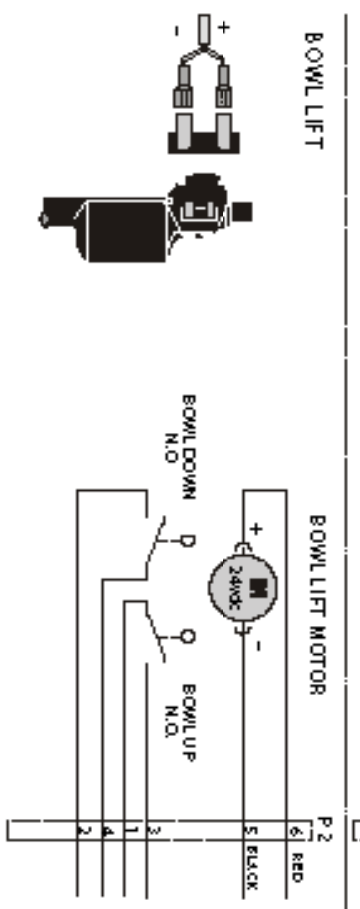
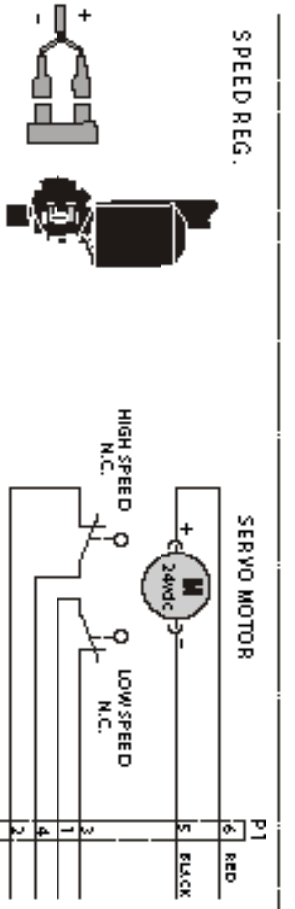

MAN-IP-AUT
 Switch between:
 AUT = Normal Use
 MAN = Adjustment (service position)

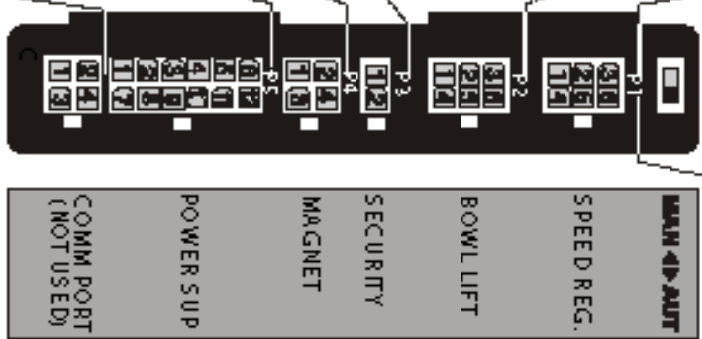

Microswitch position	
Max. speed	N.C.
Min. speed	N.C.
Bowl up	N.O.
Bowl down	N.O.
Security (Ready)	N.C.

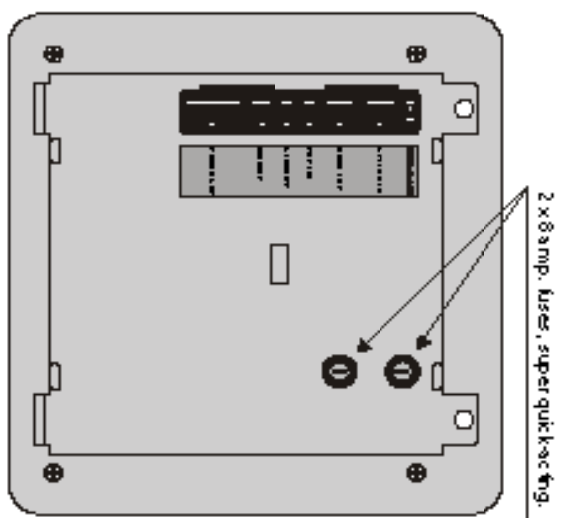

CONTROL BOX
 SEEN FROM BEHIND

Power Supply Wiring Diagram

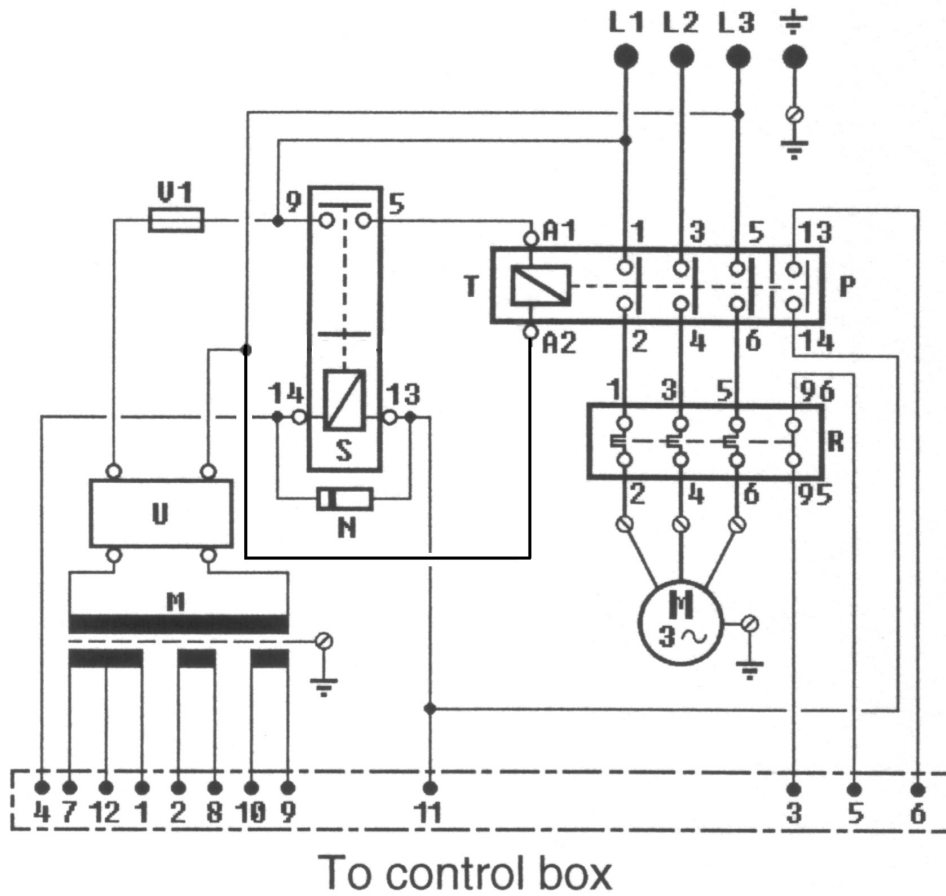

Sockets in power supply.



- M Transformer
- N..... Diode 1N4003
- P Auxiliary switch
- R..... Thermal overload relay
- S Relay 24vdc
- T Relay for motor
- U Filter
- V1 ... Fuse 1.5 Amp
- W Rectifier



FI G €À[~ c@Ša ^Öiã^
Ô@€[c^Êp ÔÁG Ĩ H
Ú@} ^Á(800) 222-1138
QæÁ € Ě ì HĚ Ĩ €H
