

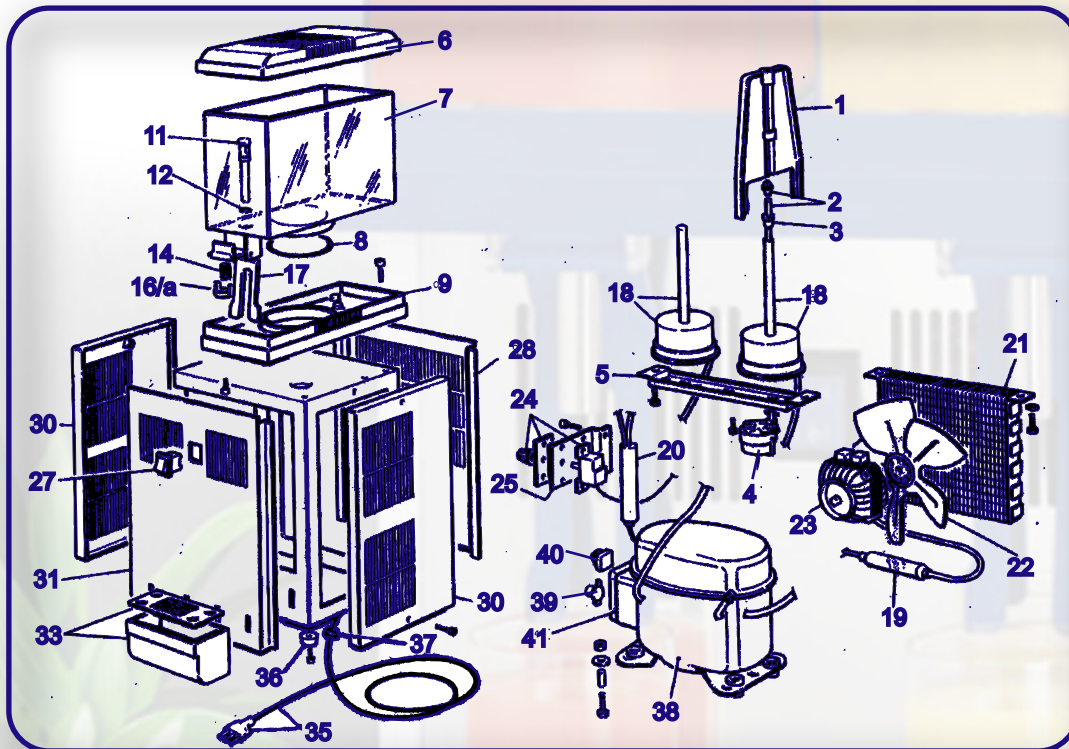

**Costruzione Attrezzature Bar s.p.a.**  
 Via Campana, 233 - 80078 - Pozzuoli (NA)  
 tel. +39 081 526.11.11 - fax +39 081 526.5873  
**WEB: <http://www.cabspa.com>**  
**MAIL: [info@cabspa.com](mailto:info@cabspa.com)**



TIPO MACCHINA MACHINE TYPE		REFRIGERATORE DI BEVANDE COLD DRINK DISPENSER			
MODELLO MODEL		MODEL 1	MODEL 2	MODEL 3	MODEL 4
ALIMENTAZIONE ELECTRICITY		230V/50/60Hz 115V/60Hz	230V/50/60Hz 115V/60Hz	230V/50/60Hz 115V/60Hz	230V/50/60Hz 115V/60Hz
POTENZA POWER CONSUMPTION		100 W	150 W	200 W	250 W
POTENZA COMPRESS. COMPRESS. POWER		1/8 HP	1/6 HP	1/5 HP	1/4 HP
VASCA BOWL	MATERIALE MATERIAL	POLICARBONATO ALIMENTARE			
	CAPACITA' CAPACITY	6 Lt	6 Lt X 2 = 12 Lt 9Lt X 2 = 18 Lt	6 Lt X 3 = 18 Lt 9Lt X 3 = 27 Lt	6 Lt X 4 = 24 Lt 9Lt X 4 = 36 Lt
DIMENSIONI DIMENSION	LARGHEZZA WIDTH	150 mm	300 mm	450 mm	600 mm
	PROFONDITA' DEPTH	300 mm	300 mm	300 mm	300 mm
	ALTEZZA HEIGHT	600 mm	600 mm 690 mm	600 mm 690 mm	600 mm 690 mm
	PESO NETTO NET WEIGHT	16 Kg	22.50 Kg	26 Kg	31 Kg
GAS GAZ	TIPO TYPE	R 134a	R 134a	R 134a	R 134a
	CARICA CHARGE	230V - 115V 53 gr. - 53 gr.	230V - 115V 123 gr. - 123 gr.	230V - 115V 153 gr. - 140 gr.	230V - 115V 182 gr. - 170 gr.



Bagnare la guarnizione. Poi allargarla e metterla nelle sede della vasca.

Wet the gasket. Then widen it and put it into its position.

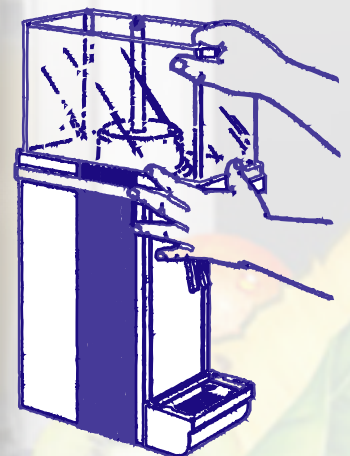

Posizionare la campana nella sua sede spingendola con le mani.

Put the bowl in its position, pushing it down by hands.

Il rubinetto attaccato alla campana, dev'essere smontato per la pulizia. Procedere come segue: premere sulla leva (3) in modo da agire lateralmente rispetto al suo corso regolare. Allo stesso tempo allargare dolcemente il supporto (6) della leva con le dita (vedi disegno D).

Una volta tolta la leva, avvicinare i due punti (7) del portamolla e sollevare: il perno rubinetto (9) è libero. Lavare le parti smontate in acqua tiepida.

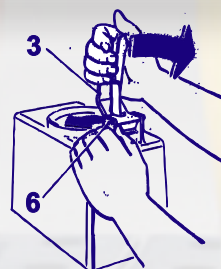

The tap attached to the bowl needs to be disassembled for cleaning. Perform as follows: Press the lever (3) to act sideways in comparison with its normal course. At the same time widen the lever support (6) using fingers (see picture D). Once the lever has been taken off, draw up the two points of the spring holder (7) and raise them: tap pin (9) is free. Wash the disassembled parts with tepid water.

## COSTRUZIONE ATTREZZATURE BAR

Via Campana, 233 - 80078 Pozzuoli (NA) - ITALY Tel. +39 081 5261111 - Fax +39 081 5265873

E-mail: info@cabspa.com - Web: www.cabspa.com

### SPARE PARTS MOD.LUKE FROM 01 /11 /2009

Posit No.	Code	Description	Price €	Q.ty
1	L8001	PLASTIC AGITATOR 6LT.		
1/A	L8099	PLASTIC AGITATOR 9LT		
2	L6102	TUBE 10X1 6 LT.		
2/A	L6124	TUBE 10 X1 9 LT.		
3	1041	PLASTIC BUSHING D15		
4	L8102	AGITATOR MOTOR TYPE 1		
	L8102/2.1	AGITATOR MOTOR TYPE2		
	P201	AGITATOR MOTOR TYPE3		
6	L8006B	WHITE COVER		
7	L8007	BOWL 6LT.		
7/A	L8098	BOWL 9 LT.		
8	L8008	BOWL O-R		
9	L8009BLU	EVAPORATOR SUPPORT		
11	L8011	TAP PIN		
12	5034	TAP O-RING		
14	L8014	TAP SPRING		
16/A	7510	ELASTIC WASHER		
17	L8017BLU	TAP HANDLE		
17/A	L6120BLU	COMPLETE BOWL 6Lt		
17/B	L6125BLU	COMPLETE BOWL 9 Lt		
19	1184	FILTER 20 gr.		
20	L8020	BOILER3 WAYS		
21	L8021	CONDENSER LUKE 2		
22	L8022	FAN D. 170 - 34°		
24	1025	THERMOSTAT		
27	L8119	MAIN SWITCH		
28	L8028	BACK PANEL LUKE 2		
30	L8030B	SIDE PANEL		
31	L8031	CONTROL PANEL LUKE 2		
33/34	L8033/34BLU	DRIP TRAY+ GRATE		
35	5025/1	FEEDER CABLE		
36	L8036	LEG		
38	L8113/3	COMPRESSOR LUKE 2		
39	L 39	CLIXON		
40	L 40	RELAY		
43	L8043	CONTROL PANEL LUKE 3		
44	L8044	BACK PANEL LUKE 3		
46	L8046	BOILER 4 WAYS		
47	L8116/2	COMPRESSOR LUKE 3		
51	L 51	RELAY		
52	L 52	CLIXON		
53	5060	CONDENSER LUKE 3		
55	L8055	FAN D. 200 - 28 °		
56	5045/5010	FAN MOTOR 5/10 WATT		
57	L8104	EXTENSION FOR CENTRAL TUBE		
59	L8087	CONTROL PANEL LUKE 4		
60	L8088	BACK PANEL LUKE 4		
62	L8090	BOILER 5 WAYS		
63	L8116/2	COMPRESSOR LUKE 4		
67	L 51	RELAY		
68	L 52	CLIXON		
69	L8086	CONDENSER LUKE 4		
70	L8092	FAN D.230 - 28°		