

PANNELLO,GRIGLIA E VASCHETTA / PANEL, DRIP TRAY AND GRATE

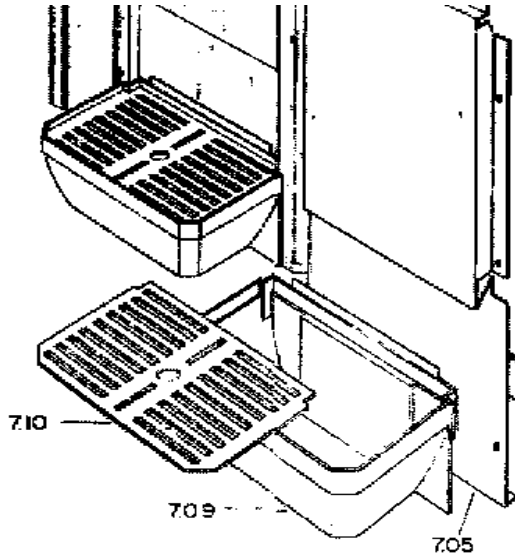

Tipo/Type 1

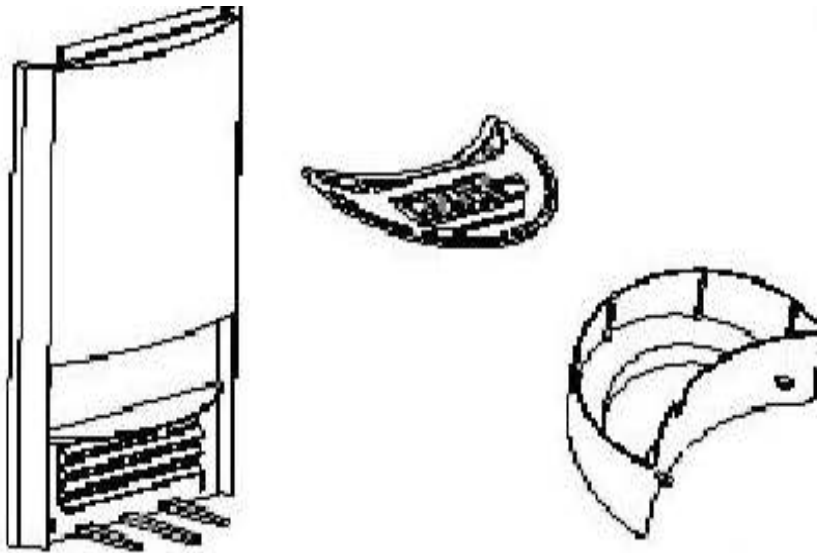

Tipo/Type 2

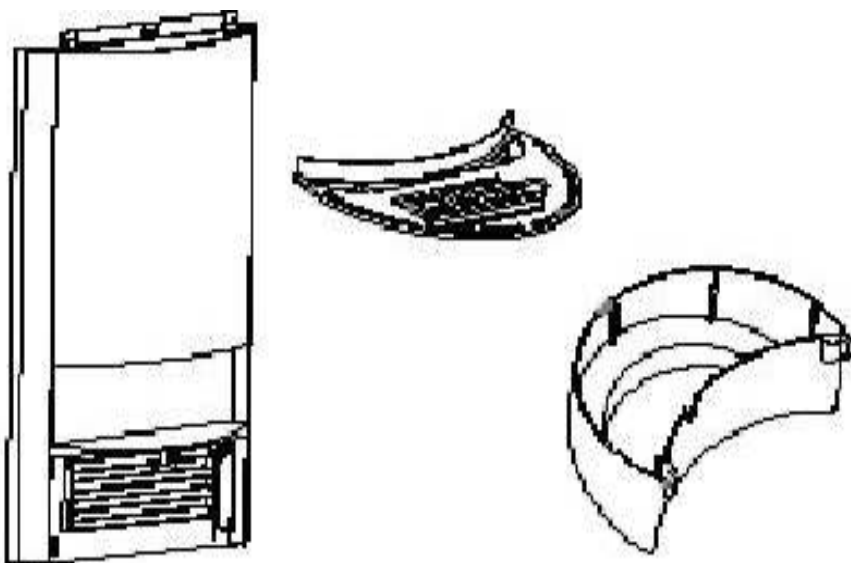

Tipo/Type 2 modif.

CAB Spa

Via Campana, 233 - 80078 Pozzuoli (NA) - Italy Tel. +39 081 5261111 - Fax +39 081 5265873 E-mail: info@cabspa.com - Web: www.cabspa.com

Posit.No.	Code	Description	Model	Q.TY
1,01	F001BM	FRONT UPPER LID BLUE	FABY	
	F001/N	FRONT UPPER LID BLACK	FABY	
1,01	F005	LOWER PART FRONT LID	FABY	
1,14	F001BM	REAR LID BLUE	FABY	
	F001/N	REAR LID BLACK	FABY	
1,14	F095	LOWER PART REAR LID	FABY	
1,02	F002	COVER HOOK WHITE	FABY	
	F002/N	COVER HOOK BLACK	FABY	
	F002/BM	COVER HOOK BLUE	FABY	
1,03	F004	DISPLAY PHOTO	FABY	
1,01	F001/NL	FRONT UPPER LID BLACK	NEW FABY	
	F001/GMB	FRONT UPPER LID SILVER	NEW FABY	
1,01	F005,1	FRONT LID LOWER COVER	NEW FABY	
1,14	F001/NL	REAR LID BLACK	NEW FABY	
	F001,1/GMB	REAR LID SILVER	NEW FABY	
	F095,1	REAR LID LOWER PART	NEW FABY	
1,02	F238	HINGE IN STAINLESS STEEL	NEW FABY	
1,05	F008/5	KIT LID LIGHT CABLE		
1,06	1236	HALOGEN BULB 12 V		
1,07	F089	BULB SOCKET		
1,08	F003	ADDITIONAL AGITATOR		
1,09	F007	AGITATOR JOINT		
1,10	F023/3	24 V STIRRING MOTOR		
	F023.2	BEARING FOR 24 V STIRRING MOTOR		
	F023.1	CONDENSER FOR 24 V STIRRING MOTOR		
	F300/C	COMPLETE LID BLUE WITH LIGHT	FABY	
	F300/NICS	COMPLETE LID BLACK WITH LIGHT	FABY	
	F300	COMPL. LID BLUE WITH LIGHT + MOTOR 24V	FABY	
	F300/N	COMPLETE LID BLACK WITH LIGHT + MOTOR 24V	FABY	
	F301BM	COMPLETE FRONT LID BLUE	FABY	
	F301/N	COMPLETE FRONT LID BLACK	FABY	
	F300/N/SA/N	COMPLETE LID BLACK WITH LIGHT	NEW FABY	
	F300/N/SA/GM	COMPLETE LID SILVER WITH LIGHT	NEW FABY	
	F300/N/DA/N	COMPL. LID BLACK WITH LIGHT + MOTOR 24V	NEW FABY	
	F300/N/DA/GM	COMPL. LID SILVER WITH LIGHT + MOTOR 24V	NEW FABY	
	F301/N/N	COMPLETE FRONT LID BLACK	NEW FABY	
	F301/N/GMB	COMPLETE FRONT LID SILVER	NEW FABY	
2,00	F304/1	COMPLETE SPIRAL WITH CAP GASKET		
	F026	SUCTION CAP GASKET	OLD T.	
2,05	F026/2	SUCTION CAP GASKET NEW	NEW T.	
3,01	FEV4B	COMPLETE EVAPORATOR BLUE SUPPORT		
	FEV4N	COMPLETE EVAPORATOR BLACK SUPPORT		
	FEV4GM	COMPLETE EVAPORATOR GREY SUPPORT		
3,02	F019	BOWL GASKET WHITE		
3,02	F019/N	BOWL GASKET BLACK		
3,03	F303	D. 12 DRIVE SHAFT		
3,04	F022/1	SEALING RING		
3,05	F226	EVAPORATOR BUSHING D. 19/12	SEE DIAG.2	
	F051	EVAPORATOR BUSHING D. 19	SEE DIAG.2	
	F051/2	EVAPORATOR BUSHING D. 29	SEE DIAG. 2	
3,06	F029/N	EVAPORATOR SUPPORT BLACK		
	F029BM	EVAPORATOR SUPPORT METAL BLUE		
	F029GM	EVAPORATOR SUPPORT GREY		
3,07	F030BM	COVER OF EVAPORATOR SUPPORT BLUE		
	F030/GM	COVER OF EVAPORATOR SUPPORT SILVER		
	F030/N	COVER OF EVAPORATOR SUPPORT BLACK		
3,08	F031	MINI DOOR WHITE		
	F031/BM	MINI DOOR METAL BLUE		

	F031/N	MINI DOOR BLACK		
3,09	F032	SCREW COVER WHITE		
	F032/BM	SCREW COVER METAL BLUE		
	F032/N	SCREW COVER BLACK		
4,01	F033	GEAR MOTOR		
	F033/1.5	KENTA GEAR POSIT.# 5		
	F033/1.4	KENTA GEAR POSIT.# 6		
	F033.6	ELCO GEAR POSIT.# 6 UNTIL DECEMBER 2003		
	F033.6 T.N.	ELCO GEAR POSIT.# 6 FROM JANUARY 2004		
	F033.7	ELCO GEAR POSIT # 7		
4,02	F036	SPRING FOR SLUSH ADJUSTMENT		
4,03	F035	SPRING GUIDE		
4,04	F034	WHEEL FOR SLUSH ADJUSTMENT		
4,05	F317	BRASS BUSHING		
4,06	F021	CLAMPING RING STOP		
4,07	1061/UL	MICROSWITCH		
5,01	F410	TEN LITERS BOWL		
	F302	COMPLETE BOWL WITH BLUE HANDLE	FABY	
	F302/N	COMPLETE BOWL WITH BLACK HANDLE	FABY	
	F302/N/W	COMPLETE BOWL WITH WHITE HANDLE	NEW FABY	
	F302/N/N	COMPLETE BOWL WITH BLACK HANDLE	NEW FABY	
	F302/N/GM	COMPLETE BOWL WITH SILVER HANDLE	NEW FABY	
5,02	F010	CROSS BAR		
5,04	F012BM	TAP HANDLE BLUE PUSH		
	F012/N	TAP HANDLE BLACK PUSH		
	F012/NL	TAP HANDLE BLACK PULL		
	F012/GMB	TAP HANDLE SILVER PULL		
5,05	F013	PIN FOR HANDLE FIXING		
5,06	F014	TAP SPRING		
5,07	F015	TAP PIN		
5,08	F016	TAP O-RING		
5,09	F017	LOWER GASKET FOR TAP		
5,10	F315/3	BOWL BUSHING		
PN. For compressors or compressor components please specify model n° and type of compressor				
6.01B	F241	COMPRESSOR 230-240 V/50 Hz 1 BOWL		
	F061/7	CONDENS. FOR COMPRESS. 1 BOWL 230-240V/50HZ		
	F061/6	RELAIS FOR COMPRESS. 1 BOWL 230-240V/50HZ		
	F061/5	CLIXON FOR COMPRESSOR 1 BOWL 230-240V/50HZ		
	F 107/4	COMPRESSOR 115V/60HZ 1 BOWL		
	F 038/1	CONDENS. FOR COMPRESSOR 1 BOWL 115V/60HZ		
	F 058/1	RELAIS FOR COMPRESSOR 1 BOWL 115V/60HZ		
	F 047/1	CLIXON FOR COMPRESSOR 1 BOWL 115V/60HZ		
	F 241/1	COMPRESSOR 220V/60HZ 1 BOWL		
	F 038/2	CONDENS. FOR COMPRESSOR 1 BOWL 220V/60HZ		
	F 058/2	RELAIS FOR COMPRESSOR 1 BOWL 220V/60HZ		
	F 047/2	CLIXON FOR COMPRESSOR 1 BOWL 220V/60HZ		
	F068/1	CONDENSER FABY 1 DEPTH 45 mm.		
6,07	F 068/2	CONDENSER FABY 1 DEPTH 60 mm.		
6.08/B	F067	FAN MOTOR 220-230-240V/50-60HZ 52 mm		
	F067/4	FAN MOTOR 220-230-240V/50-60HZ 38 mm		
	F 126/2	FAN MOTOR 115V/60HZ 38 mm		
	F 126	FAN MOTOR 115V/60HZ 51 mm		
6,09	F062	FILTER 20 gr.		
6.11/B	F213	COMPRESSOR 230-240V/50HZ TWIN BOWL		
6.16/B	F083/3	CONDENS.FOR COMPR. 230-240V/50 TWIN BOWL		
6.17/B	F081/3	RELAIS 230-240V/50 HZ TWIN BOWL		
6.18/B	F082/3	CLIXON 230-240V/50 HZ TWIN BOWL		
	F 213/1	COMPRESSOR 115V/60HZ TWIN BOWL		
	F 083/5	CONDENSER 115V/60HZ TWIN BOWL		
	F 081/5	RELAIS 115V/60HZ TWIN BOWL		
	F 082/5	CLIXON 115V/60HZ TWIN BOWL		
	F 151/1	COMPRESSOR 220V/60HZ TWIN BOWL		
	F 083/6	CONDENSER 220V/60HZ TWIN BOWL		
	F 081/6	RELAIS 220V/60HZ TWIN BOWL		

	F 082/6	CLIXON 220V/60HZ TWIN BOWL		
6,19	1184	FILTER 20 gr.		
6,21	1183	ELECTROVALVE (MEC. PART)		
6.22/A	1298	COIL 230V/50 Hz		
	1285	COIL 240V/50 Hz		
	1298/2	COIL 220V/60 Hz		
	1290/A	COIL 115V/60 Hz		
6,24	F084/2	CONDENSER FABY 2		
6.25/A	1100	FAN D. 254-28° FOR FAN MOT. 16 W F2		
6.26/C	1099	FAN MOTOR FABY 2 - 16 W 220-240V/50-60Hz		
	F 138	FAN MOTOR FABY 2 - 16 W 115V/60Hz		
6.28/B	F214	COMPRESSOR 230-240V/50 Hz THREE BOWL		
6.33/B	F083/4	CONDENSER 230-240V/50 Hz THREE BOWL		
6.34/B	F081/4	RELAIS 230-240V/50 Hz THREE BOWL		
6.35/B	F082/4	CLIXON 230-240V/50 Hz THREE BOWL		
	F 214/1	COMPRESSOR 115V/60HZ THREE BOWL		
	F 083/9	CONDENSER 115V/60HZ THREE BOWL		
	F 081/7	RELAIS 115V/60HZ THREE BOWL		
	F 082/8	CLIXON 115V/60HZ THREE BOWL		
	F 214/2	COMPRESSOR 220V/60HZ THREE BOWL		
	F 083/8	CONDENSER 220V/60Hz Hz THREE BOWL		
	F 081/1	RELAIS 220V/60HZ THREE BOWL		
	F 082/7	CLIXON 220V/60HZ THREE BOWL		
6,36	1201	THREE WAY DISTRIBUTOR		
6,37	F084/2	CONDENSER THREE BOWL 60 mm.		
6,37	F084/3	CONDENSER THREE BOWL 90 mm.		
6,38	1112	FAN D 254-34°		
6,39	1113	FAN MOTOR 220-240V/50-60 Hz THREE BOWL		
	F 215	FAN MOTOR 115V/60HZ THREE BOWL 25W		
7,01	F039	CONDENSATION DRIP TRAY PANEL BLUE		
	F039/N	CONDENSATION DRIP TRAY PANEL BLACK		
	F039GM	CONDENSATION DRIP TRAY PANEL SILVER		
7,02	1087	CONDENSATION TUBE OUTLET		
7,05	F044/A	DRIP TRAY PANEL IN STAINLESS STEEL		
	F044/P	DRIP TRAY PANEL WHITE (Type 2)	SEE DIAG 3	
	F044/N	DRIP TRAY PANEL BLACK (Type 2)	SEE DIAG 3	
	F044W04	DRIP TRAY PANEL WHITE (Type 2 mod.)	SEE DIAG 3	
	F044N04	DRIP TRAY PANEL BLACK (Type 2 mod.)	SEE DIAG 3	
	F044BM04	DRIP TRAY PANEL BLUE MET (Type 2 mod.)	SEE DIAG 3	
7,06	F072/N	BACK PANEL IN PLASTIC BLACK		
	F072BM	BACK PANEL IN PLASTIC BLUE METAL		
	F046/N	ANGLE BAR BLACK	FABY	
7,08	F046BM	ANGLE BAR BLUE METAL	FABY	
7.09/7.10	F059+F060BM	DRIP TRAY + GRATE BLUE (Type 1)	SEE DIAG 3	
	F059/N+F060/N	DRIP TRAY + GRATE BLACK (Type 1)	SEE DIAG 3	
	F059/60/N/B	DRIP TRAY + GRATE BLUE (Type 2)	SEE DIAG 3	
	F059/60/N/N	DRIP TRAY + GRATE BLACK (Type 2)	SEE DIAG 3	
	F059/060B04	DRIP TRAY + GRATE BLUE (Type 2 mod.)	SEE DIAG 3	
	F059/060N04	DRIP TRAY + GRATE BLACK (Type 2 mod.)	SEE DIAG 3	
	F059/060GM04	DRIP TRAY + GRATE SILVER (Type 2 mod.)	SEE DIAG 3	
7,11	F417	SUPPORTING LEG + PIN		
	1023 NSF	SUPPORTING LEG USA		
7,13	1032	CABLE CLAMP		
7,14	1231	POWER CABLE		
	1231 U.K./1	POWER CABLE UK		
	2010/1	POWER CABLE 115V		
	1231/1 AUSTR.	POWER CABLE AUSTRALIA		
7,16	1240	FUSE HOLDER		
7.17/7.32	1027	FUSE 16 A		
	1237	FUSE 25 A		
	F 147	FUSE 4 A		
7.18/B	1016	TIMER MOTOR 220-240V/50-60 Hz		
	1239	TIMER MOTOR 115V/60HZ		
7,19	1025	THERMOSTAT		

7,23	F049/2	TRANSFORMER 60 VA - 230 V/12-24V ONE BOWL		
	F049/4	TRANSFORMER 60 VA - 230 V/11V ONE BOWL		
7,24	F049/2	TRANSFORMER 60 VA - 230 V/12-24V TWIN BOWL		
	F049/4	TRANSFORMER 60 VA - 230-240V/11V TWIN BOWL		
7,33	F049/4	TRANSFORMER 60 VA - 230-240V/11V THREE BOWL		
	F 279	TRANSFORMER 75 VA - 230-240V/12-24V		
7,23	F 091 UL /1	TRANSFORMER 60 VA - 115V/11-24V		
	F 280	TRANSFORMER 75 VA - 115V/11 -24V		
7.24/7.33	F 245	TRANSFORMER 60 VA - 115V/11V		
7,34	F131	MAIN POWER SWITCH		
7,35	F133	UNIPOLAR DEVIATOR SW. SLUSH - COLD DRINK		
7,36	F132	SWITCH - LIGHT - MOTOR - AGITATOR		
7,37	1350	BIPOLAR DEVIATOR SWITCH SLUSH / COLD DRIN		
7,40	F206	CONTROL PANEL WHITE		
	F206/N	CONTROL PANEL BLACK		
	F206BM	CONTROL PANEL BLUE METAL		
7,41	F207	SIDE PANEL WHITE		
	F207/N	SIDE PANEL BLACK		
	F207BM	SIDE PANEL BLUE METAL		
	F258	STICKER FRONT PANEL		
	F218/5	STICKER CONTROL PANEL ONE BOWL		
	F218	STICKER CONTROL PANEL 1 BOWL D.A.		
	F216/5	STICKER CONTROL PANEL TWIN BOWL		
	F216	STICKER CONTR. PANEL TWIN BOWL D.A.		
	F217/5	STICKER CONTROL PANEL THREE BOWL		
	F217	STICKER CONTROL PANEL THREE BOWL D.A.		
	F240/1	FUSE HOLDER FOR TRANSFORMER		
	F242	FUSE 5 AMP. GLASS		
	F239	FUSE 4 AMP. GLASS		
	F604	FUSE 2 AMP. GLASS		
	F264	PLASTIC SCREW FOR SIDE PANEL		
	F139	VASELINE TUBE		
	F228	TIMER 115V/60HZ		
	F265	COVER FOR CONTROL PANEL		
	F174	HANDLE LOCK	FABY	
	F266	HANDLE LOCK	NEW FABY	
	F195/1	FLAT LID SHERBERT TRANSPARENT		
	F195N/1	FLAT LID SHERBERT BLACK		