

**RESERVEDELSMANUAL
SPARE PART MANUAL
ERSATZTEILMANUAL**

RN10 VL-2

Gyldig fra maskinnummer:

Valid from machine number:

Gültig ab Maschinenummer:

10009166

dato / date	Maskinnr. / Machine no.	Del / Part	Side / Page
052010	10007000	planetjul og aksler / planet wheel and shafts	Rørehoved / planetary head
	10009148	Aftagelig plastiskærm / removable plastic guard	Sikkerhedsskærm / Safety guard
122014	10009166	Låg, ramme, skruer, sikring / Lid, frame, screws and fuse	Stativ / Coloumn
112016		Rustfri ben, bordmodel / SS legs, table model	Stativ / Machin column
012017	10010184	Kedeldetektering / Bowl detection	Kedeldetektering / Bowl detection
012017	10010184	Kedel - kedekdetektering/ bowl - bowl detection	Kedler og værktøj / Bowls and mixing tools
012017	10010184	El-diagram	El-diagram

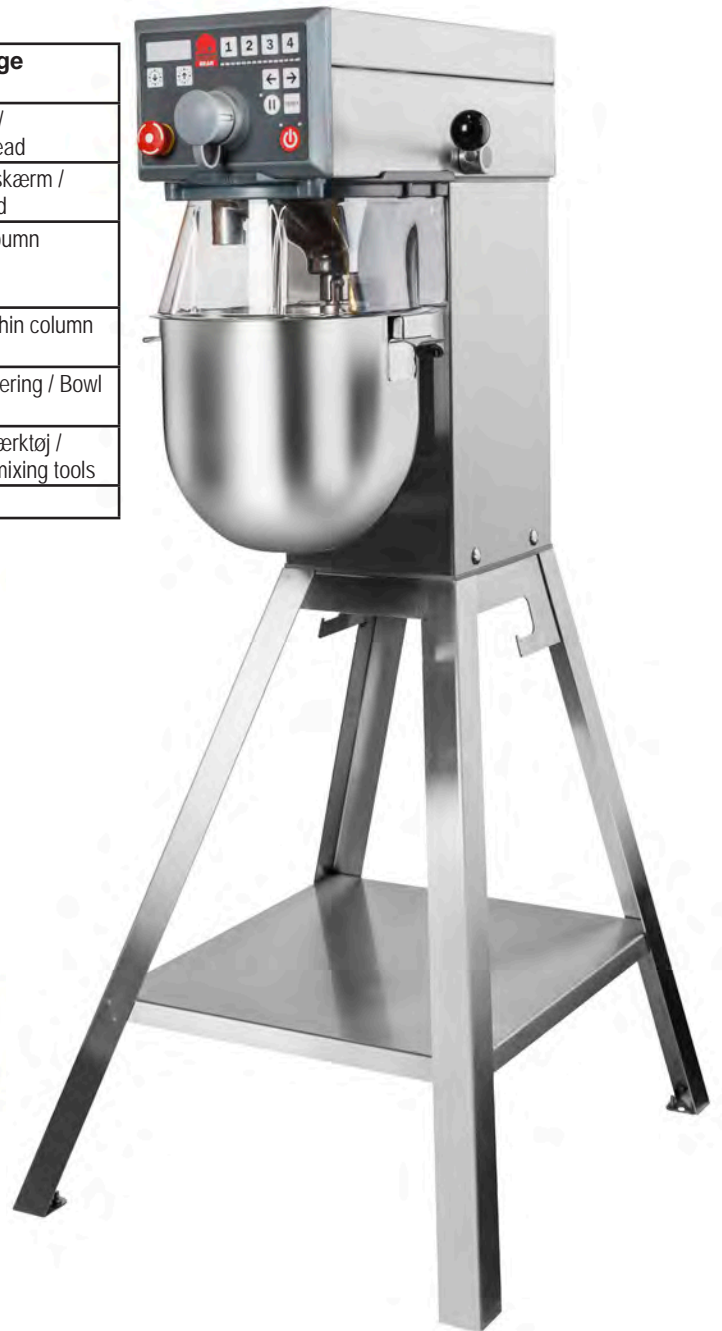

012017 ORDER NO.: 00240_VL2 DK-GB-D

A/S WODSCHOW & Co.

Kirkebjerg Søpark 6
DK-2605 Brøndby

Denmark

Phone: +45 43 44 22 88
info@wodschow.dk
www.bearvarimixer.com

TRANSMISSION.....	TRANSMISSION.....	TRANSMISSION	3
RØREHOVED FØR 10007000 ...	PLANETARY HEAD BEFORE 10007000	RÜHRKOPF VOR 10007000	4
RØREHOVED FRA 10007000 ...	PLANETARY HEAD FROM 10007000.....	RÜHRKOPF VON 10007000	6
HJÆLPETRÆK	ATTACHMENT DRIVE	ANSCHLUSSGETRIEBE	8
KEDELDETEKTERING	BOWL DETECTION	KESSELFÜHLER	9
STATIV FØR 10009166	MACHINE COLUMN BEFORE 10009166.....	MASCHINENSTÄNDER VOR 10009166.....	10
STATIV FRA 10009166	MACHINE COLUMN FROM 10009166.....	MASCHINENSTÄNDER VON 10009166.....	12
SIKKERHEDSSKÆRM	SAFETY GUARD	SCHUTZSCHIRM	14
LØFTESYSTEMER.....	LIFTING SYSTEM	HUBSYSTEM	16
ELEKTRISKE KOMPONENTER	ELECTRIC COMPONENTS.....	ELEKTRISCHE KOMPONENTEN	18
KEDLER OG RØREVÆRKTØJ.....	BOWLS AND MIXING TOOLS.....	KESSEL UND RÜHRWERKZEUGE.....	20
KABLINGSDIAGRAM.....	CABLE DIAGRAM	KABELLAGEPLAN	21
ELDIAGRAM.....	WIRING DIAGRAM	SCHALTPLAN	22

Der tages forbehold for konstruktionsændringer

All rights reserved for changes in construction

Konstruktionsänderungen vorbehalten

BESTILLING AF RESERVEDELE:

ORDERING OF SPARE PARTS:

BESTELLUNG VON ERSATZTEILEN:

Salg af reservedele til vore maskiner varetages af vor **reservedelsafdeling**. Ved bestilling af reservedele skal følgende oplysninger gives:

1. Maskinens type
2. Maskinens nummer
3. Reservedelens bestillingsnummer. (Order no.)
4. Eventuel forsendelsesmetode

Mangler en af ovenstående oplysninger, vil det være en fordel at kontakte vor **reservedelsafdeling**, før ordren afgives, idet vi så kan være behjælpelig med at finde det korrekte reservedelsnummer (**order no.**) på reservedelen.

Enkelte reservedele sælges ikke alene, i disse tilfælde står der ved positionsnummeret en henvisning til det samlingsnummer der skal bruges ved bestilling. Samlingsnumre er afbildet på de relevante sider

Returnering af reservedele kan kun ske efter forudgående aftale med **A/S WODSCHOW & CO.**

Sale of spare parts for our mixers is attended by our **spare part department**. When ordering spare parts, the following information must be given:

1. Type of machine
2. Number of the machine
3. Article number of the spare part in question. (Order no.)
4. Method of conveyance

If one of the above pieces of information is missing, please contact our **spare part department** before placing the order, as then we can assist you in finding the correct article number (**order no.**) of the spare part in question.

A few spare parts are not sold alone, in such cases reference is made at the pos.number to the assembly number to be used for ordering. The assembly numbers are shown on the relevant pages.

Returning of spare parts is only allowed when agreed with **A/S WODSCHOW & CO.**

Verkauf von Ersatzteilen für unsere Maschinen wird von unserer **Ersatzteilabteilung** wahrgenommen. Bei Bestellung von Ersatzteilen, geben Sie bitte folgende Auskünfte:

1. Maschinenmodell
2. Nummer der Maschine
3. Bestellnummer des Ersatzteiles. (Order no.)
4. Evt. Versandart

Falls eine der obenerwähnten Auskünfte fehlt, setzen Sie sich bitte vor Bestellung mit unserer **Ersatzteilabteilung** in Verbindung, da wir Ihnen dann behilflich sein können, die korrekte Ersatzteilnummer (**order no.**) zu finden.

Einzelne Ersatzteile werden nicht allein verkauft. In diesen Fällen gibt es bei der Pos.Nummer einen Hinweis auf die Sammlungsnummer, die bei Bestellung verwendbar ist. Die Sammlungsnummern sind auf den relevanten Seiten gezeigt.

Zurücksendung von Ersatzteilen nur nach vorausgehender Vereinbarung mit **A/S WODSCHOW & CO.**

Fig Order
no. no.

Beskrivelse

Description

Beschreibung

- | | | | | |
|-----|---------------|-------------------------------------|-------------------------------------|----------------------------------|
| 1. | CR10-128 | Remhjul 12J45 | pulley12J45 | Riemenscheibe12J45 |
| 2. | CR10-129 | Remhjul 12J125..... | pulley12J125 | Riemenscheibe12J125 |
| 3. | CR10-61 | Motor plade..... | Base for motor | Traverse für Motor |
| 4. | CR10-85 | Motor CR10 VL2..... | Motor CR10 VL2..... | Motor CR10 VL2 |
| 5. | CR10-90 | Poly-V Rem TL 80-5M-15 1108 F | Poly-V Rem TL 80-5M-15 1108 F | Poly-V Riemen TL 80-5M-15 1108 F |
| 6. | STA2004..... | Pasfeder 6x6x27 AB | Key 6x6x27 AB | Feder 6x6x27 AB |
| 7. | STA3407 | Sikringsring A 19 | circlip A 19 | sprengring A 19 |
| 8. | STA5622..... | cyl.skr.m.i.6kt M6X20..... | Screw M6x20..... | Schraube M6x20 |
| 9. | STA5813..... | Møtrik M5 elforz | Nut M5 | Mutter M5 |
| 10. | STA6007 | RF-skive M5..... | Washer M5 | Scheibe M5 |
| 11. | STA6008..... | RF-skive M6 * 4 x 12..... | Washer M6 * 4 x 12..... | Scheibe M6 * 4 x 12 |
| 12. | CR10-210 | Motor gummi dæmper..... | Motor rubber softner | Motor Gummi Dämpfer |

CR10-85M ... Motor samlet CR10 VL2.....Motor mounted CR10 VL2.....Motor montiert CR10 VL2

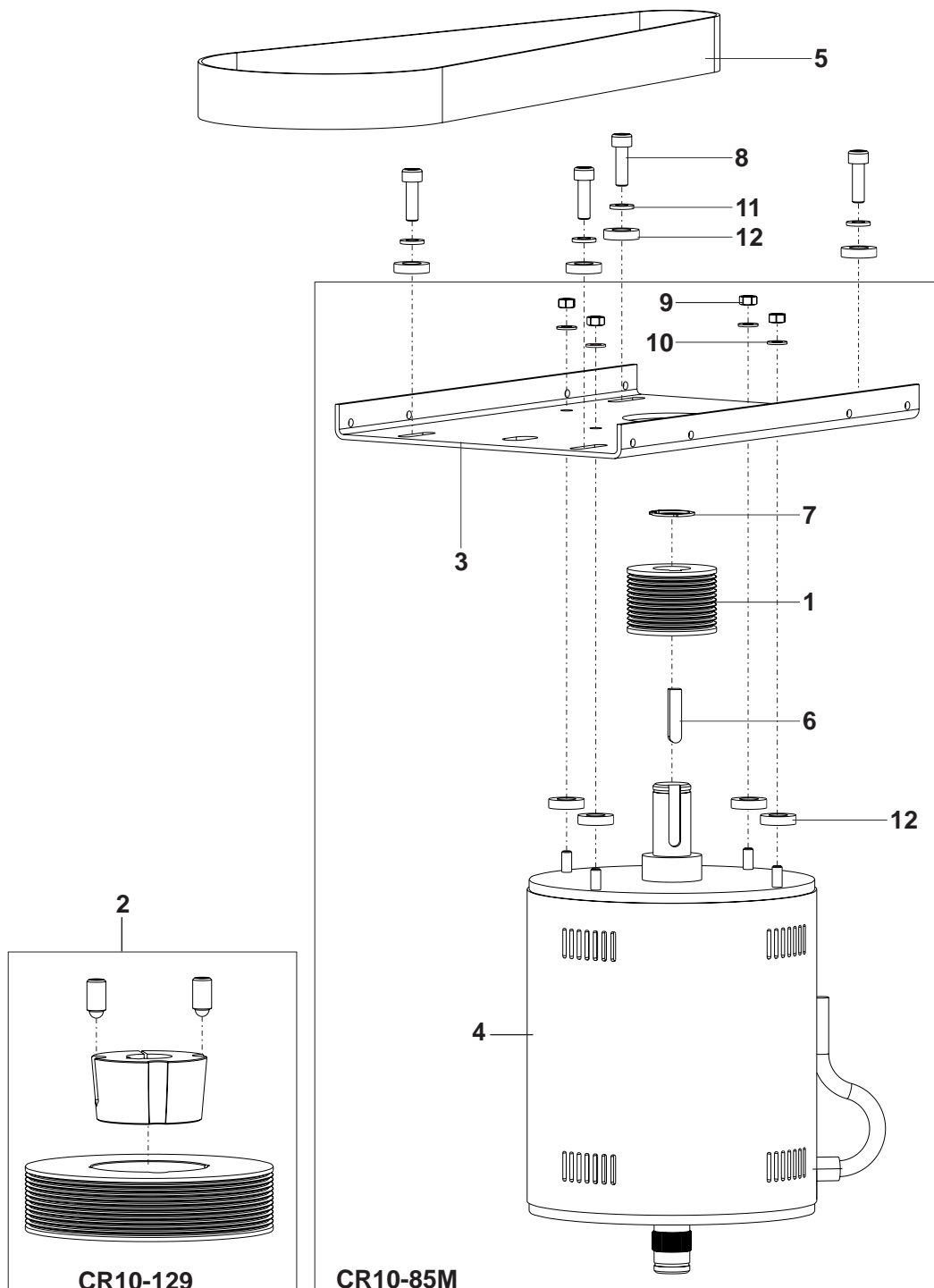

Til maskinnummer

To machine number

Biss Maschinenummer

10006999

10006999

10006999

Fig no.	Order no.	Beskrivelse	Description	Beschreibung
1.	01016.1	Kronhjul	Crown wheel	Kronrad
2.	01017-	Planethjul	planet wheel	Planetenrad
3.	01024-	Tandkrans	gear wheel rim	Zahnkranz
4.	01029-	afstandsring	spacer ring	Abstandring
5.	01217.1	Støtteskive	support washer	Stuetzscheibe
6.	42CR10-105	Bajonet holder	Bayonet holder	Bajonettfassung
7.	6005 2RS	Leje 6005 2RS	bearing 6005 2RS	Lager 6005 2RS
8.	6006 2RS	Leje 6006 2RS.1-C3	bearing 6006 2RS.1-C3	Lager 6006 2RS.1-C3
9.	CR10-2.1	Rørehoved forberedt f. skraber	Planetary head prep.f. scraper	Rührkopf vorber. f. Abstreifer
10.	CR10-3	Hovedleje bearbejdet	Main bearing machined	Hauptlager bearbejdet
11.	CR10-22.67	Bolt for hovedleje	bolt for main bearing	Bolzen für Hauptlager
12.	CR10-33.2	Bajonet aksel monteret	Bayonet shaft mounted	Bajonettwelle montiert
13.	CR10-30M	Hovedaksel monteret	Main shaft mounted	Hauptwelle montiert
14.	HK2216	Nåleleje HK2216	needle bearing HK2216	nadellager HK2216
15.	HK3516	Nåleleje HK 3516	needle bearing HK 3516	nadellager HK 3516
16.	R40-108R	Olietætningsring G30x37x4	Oilseal G30x37x4	Öldichtungsring G30x37x4
17.	STA3410	Sikringsring A 25	circlip A 25	Sprengring A 25
18.	STA3413	Sikringsring A 18	circlip A 18	Sprengring A 18
19.	STA3512	Sikringsring J 47x1.75	circlip J 47x1.75	Sprengring J 47x1.75
20.	STA5654	Tapskrue M6x16	Screw M6x16	Schraube M6x16
21.	STA5669	pasbolt M5x12	Fitted bolt M5x12	Passbolzen M5x12
22.	STA5720	Cylinderskrue M5x8 DIN7984	Screw M5x8 DIN7984	Schraube M5x8 DIN7984
23.	STA5837	Topmøtrik M5	top nut M5	mutter M5
24.	STA6451	Kærvstift KS4 ø5x10	groov pin KS4 ø5x10	kerbstift KS4 ø5x10

CR10-2.1M Rørehoved forber. f. skraber, mont. Planetary head prep.f. scraper, mount. Rührkopf vorber. f. Abstreifer, mont.

CR10-2.1Z rørehoved med leje monteret planetary head with bearing mounted Rührkopf mit Lager montiert.

CR10-3M Hovedleje monteret Main bearing mounted Hauptlager montiert

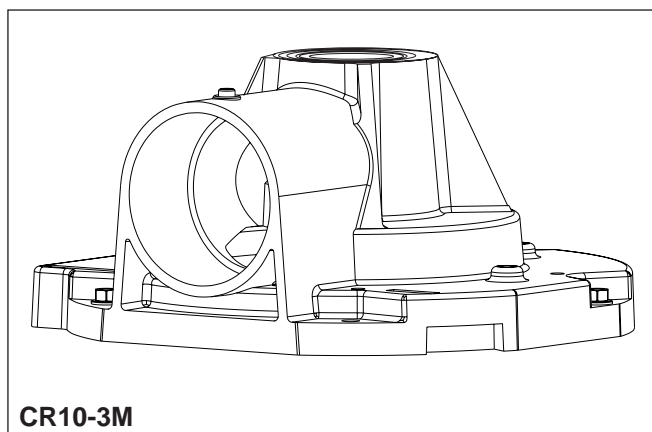
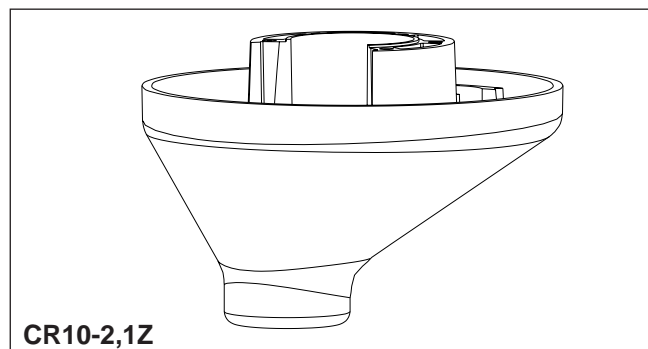
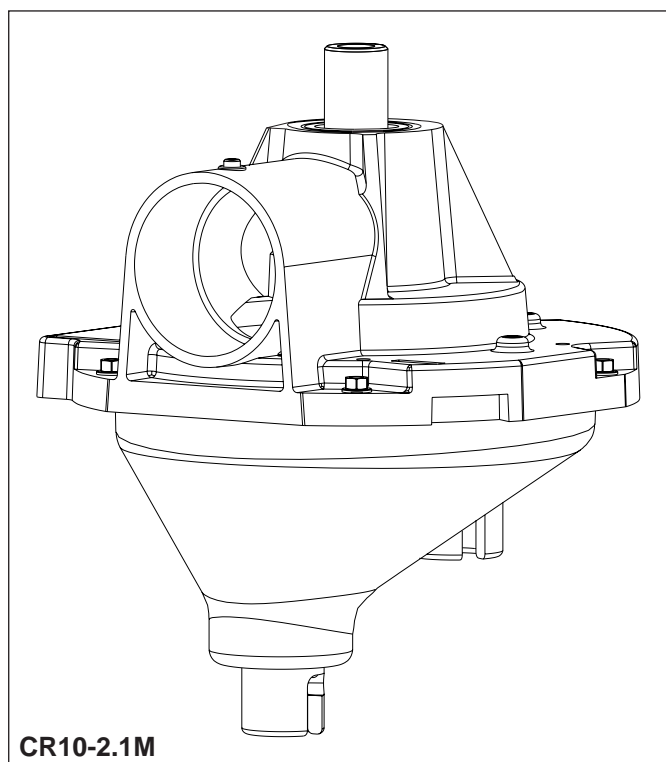

Til maskinnummer
10006999

To machine number
10006999

Biss Maschinennummer
10006999

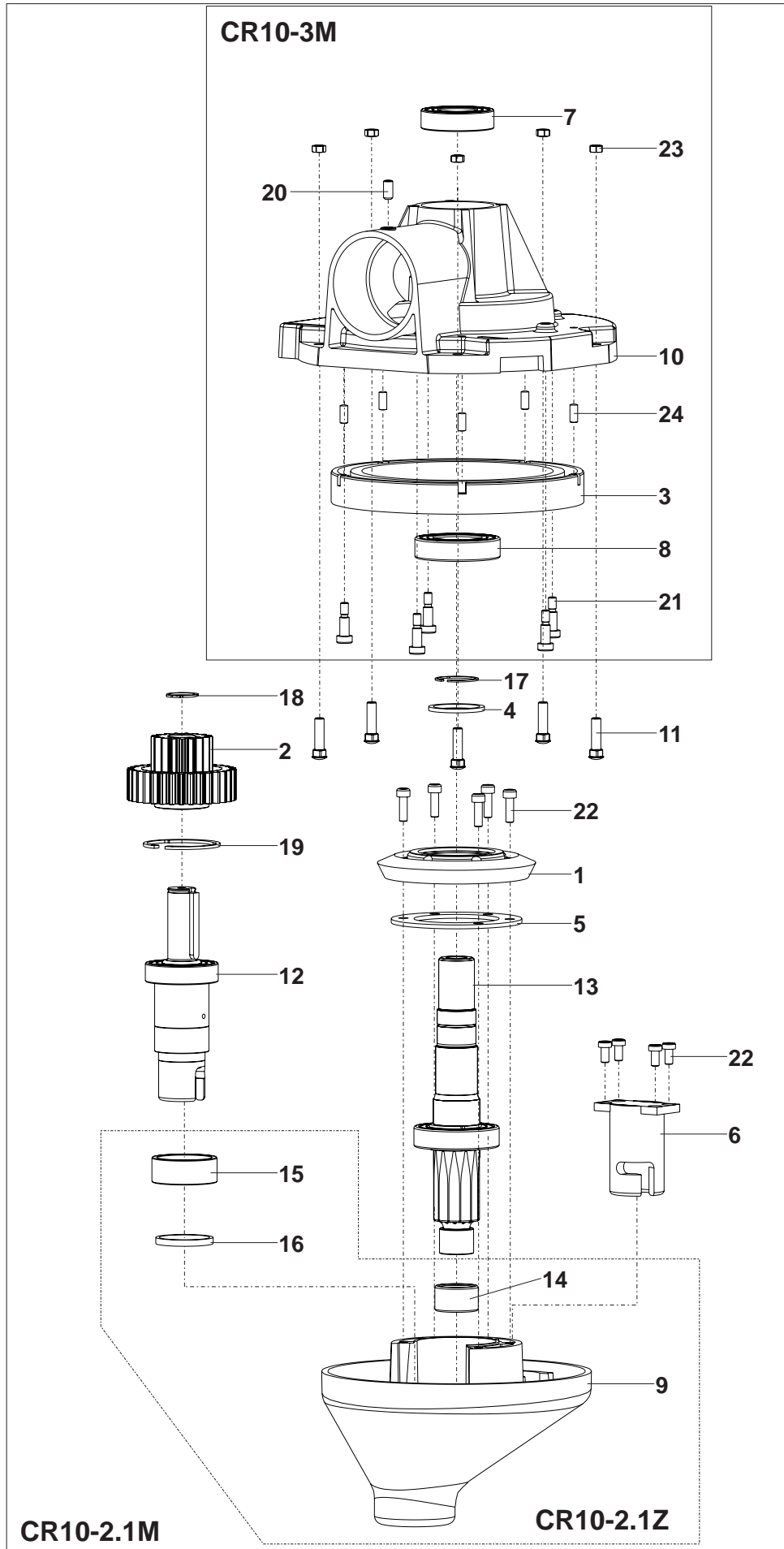

Fra maskinnummer

From machine number

Von Maschinenummer

10007000

10007000

10007000

Fig no.	Order no.	Beskrivelse	Description	Beschreibung
1.	01016.1	Kronhjul	Crown wheel	Kronrad
2.	01017.4	Planethjul lille	planet wheel small	Planetenrad klein
2A.	01017.5	Planethjul stort	planet wheel big	Planetenrad gross
3.	01024-	Tandkrans	gear wheel rim	Zahnkranz
4.	01029-	afstandsring	spacer ring	Abstandring
5.	01217.1	Støtteskive	support washer	Stuetzscheibe
6.	42CR10-105	Bajonet holder	Bayonet holder	Bajonettfassung
7.	6005 2RS	Leje 6005 2RS	bearing 6005 2RS	Lager 6005 2RS
8.	6006 2RS	Leje 6006 2RS.1-C3	bearing 6006 2RS.1-C3	Lager 6006 2RS.1-C3
9.	CR10-2.1	Rørehoved forberedt f. skraber	Planetary head prep.f. scraper	Rührkopf vorber. f. Abstreifer
10.	CR10-3	Hovedleje bearbejdet	Main bearing machined	Hauptlager bearbeitet
11.	CR10-22.67	Bolt for hovedleje	bolt for main bearing	Bolzen für Hauptlager
12.	CR10-33.1M	Bajonet aksel monteret	Bayonet shaft mounted	Bajonettwelle montiert
13.	CR10-30.1M	Hovedaksel mont., skråfortandet	Main shaft mounted, helical	Hauptwelle mont., Schräg Zahn
14.	HK2216	Nåleleje HK2216	needle bearing HK2216	nadellager HK2216
15.	HK3516	Nåleleje HK 3516	needle bearing HK 3516	nadellager HK 3516
16.	R40-108R	Olietætningsring G30x37x4	Oilseal G30x37x4	Öldichtungsring G30x37x4
17.	STA3410	Sikringsring A 25	circlip A 25	Sprengring A 25
18.	STA3404	Sikringsring A 18	circlip A 18	Sprengring A 18
19.	STA3512	Sikringsring J 47x1.75	circlip J 47x1.75	Sprengring J 47x1.75
20.	STA5654	Tapskrue M6x16	Screw M6x16	Sraube M6x16
21.	STA5669	pasbolt M5x12	Fitted bolt M5x12	Passbolzen M5x12
22.	STA5720	Cylinderskrue M5x8 DIN7984	Screw M5x8 DIN7984	Sraube M5x8 DIN7984
23.	STA5837	Topmøtrik M5	top nut M5	mutter M5
24.	STA6451	Kærvstift KS4 ø5x10	groov pin KS4 ø5x10	kerbstift KS4 ø5x10

CR10-2.2M Rørehoved forber. f. skraber, mont. Planetary head prep.f. scraper, mount. Rührkopf vorber. f. Abstreifer, mont.

CR10-2.1Z rørehoved med leje monteret. planetary head with bearing mounted Rührkopf mit Lager montiert.

CR10-3M Hovedleje monteret. Main bearing mounted Hauptlager montiert

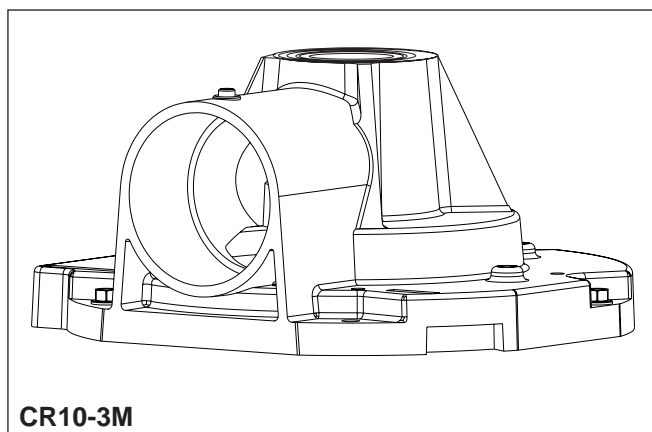
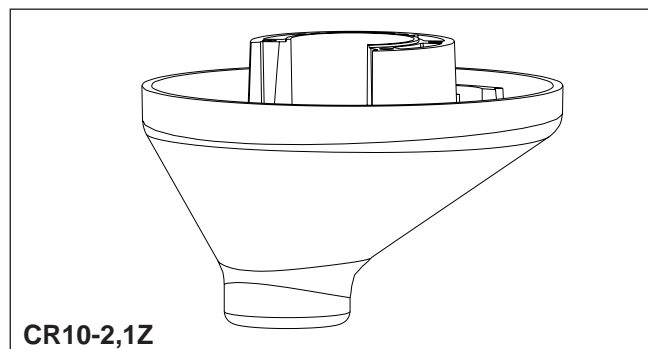
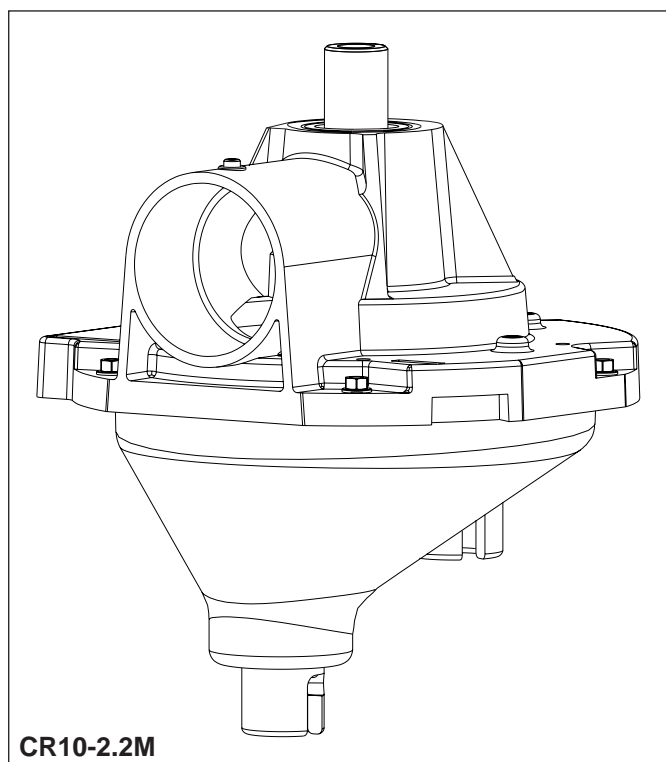

Fra maskinnummer 10007000	From machine number 10007000	Von Maschinenummer 10007000
-------------------------------------	--	---------------------------------------

CR10-3M

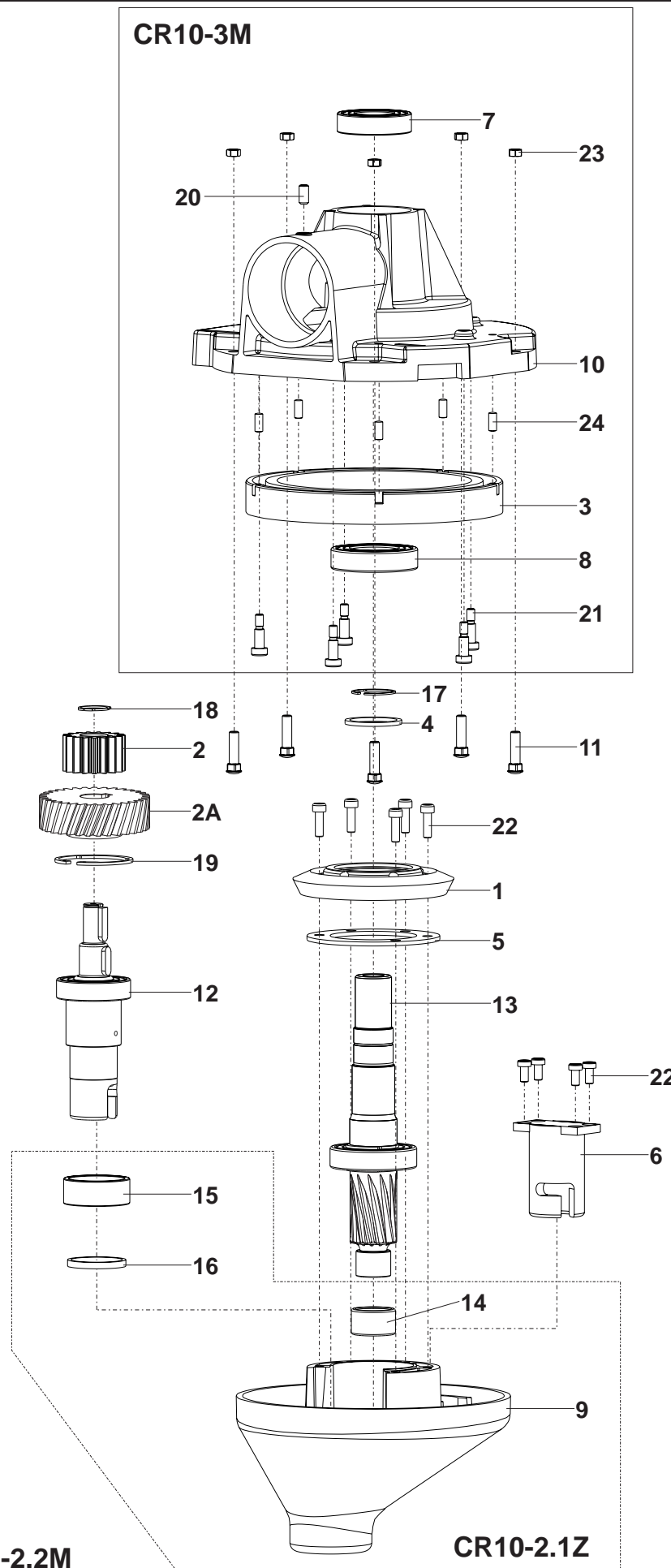

CR10-2.2M

CR10-2.1Z

Fig Order
no. no.

Beskrivelse Description Beschreibung

1. CR10-211 Pakning for hjælpetræk Gasket for attachment drive Dichtung für Anschlussgetriebe
2. CR10-215 Dæksel til hjælpetræk - 5L cover for Attachment drive - 5L Schutzdeckel für Anschlussgetriebe - 5L
3. CR10-215.1 Dæksel til hjælpetræk - 10L cover for Attachment drive - 10L Schutzdeckel für Anschlussgetriebe - 10L
4. STA5563 Fingerskrue M6 x 16 finger screw M6 x 16 Fingerschraube M6 x 16

CR10-8M Hjælpetræk monteret 10L Attachment drive mounted 10L Anschlussgetriebe montiert 10L
 CR10-8.1M Hjælpetræk monteret - 5L Attachment drive mounted 5L Anschlussgetriebe montiert 5L

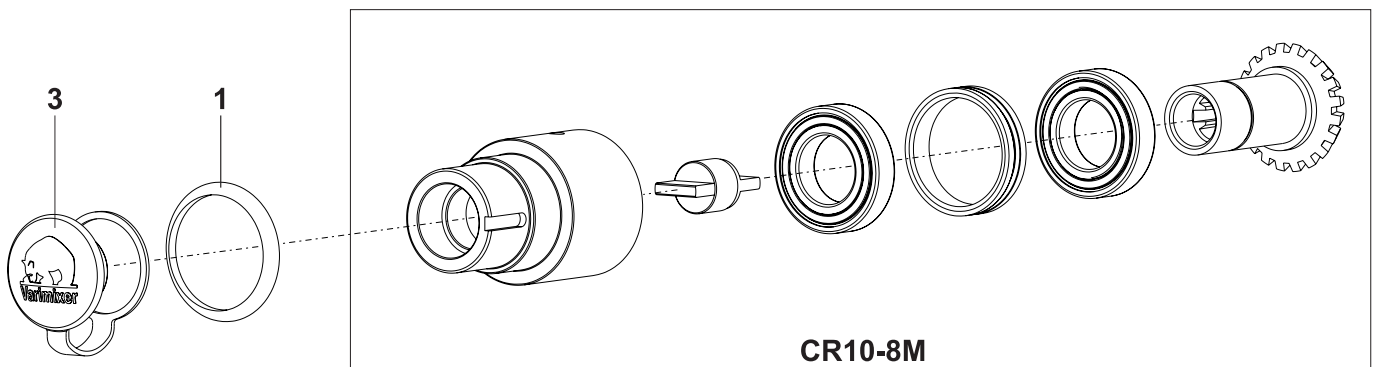
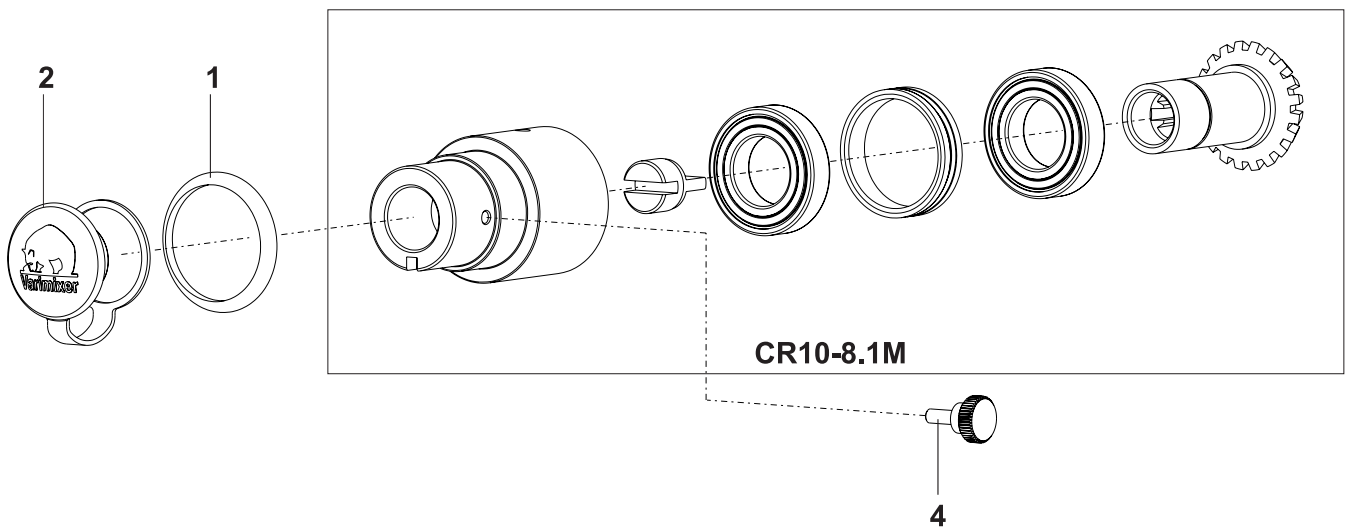

Fra maskinnummer

From machine number

Ab Maschinenummer

100010182

ITEM	QTY	Part number	Name	Name UK
1	1	56CR10-111M	Switch kedeldetektering	Switch bowldetection
2	2	STA6008	Skive $\varnothing 6,4/\varnothing 12,5 \times 1,6 \text{mm}$	Flatwasher $\varnothing 6,4/\varnothing 12,5 \times 1,6 \text{mm}$
3	2	STA5819	Møtrik M6	Hexagon nut M6
4	2	STA5319	Sekskantskrue M6x35	Hex cap screw M6x35
5	1	R20-196.16	Kabel lus	Cable

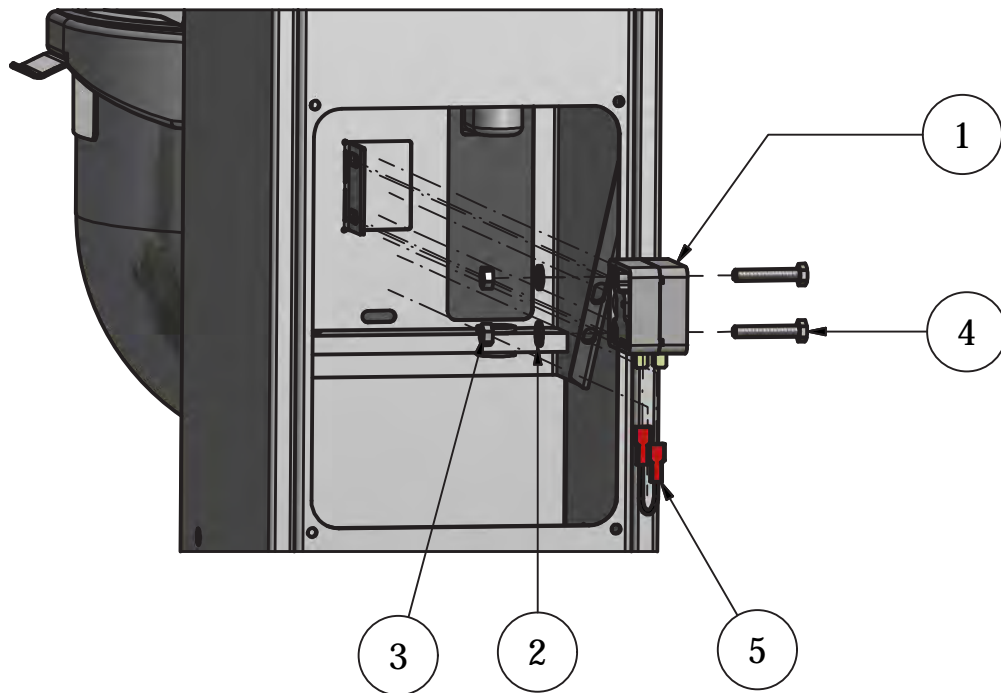

Til maskinnummer	To machine number	Biss Maschinenummer
10009165	10009165	10009165

Fig no.	Order no.	Beskrivelse	Description	Beschreibung
1.	AR005-418-00001	Sikring Træg 5 Amp	fuse slow 5A	Sicherung träge 5A
2.	CR10-21.1	Låg	topcover	deckel
3.	CR10-22.13	Ramme	Frame	Rahmen
4.	* CR10-22.17R	Bagplade	Back plate	Hinterboden
5.	CR10-22.30	Tårn	Column	Ständer
6.	CR10-22.35	Bundplade	Base plate	bodenplatte
7.	CR10-22.77	Gear plade	Plate for gear	Getriebeplatte
8.	CR10-25.1M	Fod venstre monteret	Left foot mounted	Fuss links montiert
9.	CR10-25.2M	Fod højre monteret	Right foot mounted	Fuss rechts montiert
10.	CR10-43	Holder for kedel	holder for bowl	Kesselhalter
11.	CR10-43.1	Pakning for kedelholder	Gasket for holder for bowl	Dichtung für Kesselhalter
12.	CR10-207	Pakning for tårn	Gasket for column	Dichtung für ständer
13.	CR10-218	Gummifod	rubberpad	gummifuss
14.	CR10-302	Stag	Tie rod	Stag
15.	CR10-310	Fjeder til dækplade	retaining spring f/plate	deckplattenklemme
16.	STA5080	Maskinskrue M6x10	Screw M6x10	Schraube M6x10
17.	STA5237	Pladeskrue	selftapping screw	Schneidschraube
18.	STA5622	Cylinderskrue M6x20	Screw M6x20	Schraube M6x20
19.	STA5686	Skrue M8x25 A2	Screw M8x25 A2	Schraube M8x25 A2
20.	STA5317	Cylinderskrue M5 x 10	Screw M5 x 10	Schraube M5 x 10
21.	STA6007	skive M5	washer 5mm	Scheibe 5mm
22.	STA6008	skive M6 * 4 x 12	washer M6 * 4 x 12	Scheibe M6 * 4 x 12
23.	STA7210	El-brønd 1F nul+jord - TIL 5L	Cable plug 1F neutral+earth	Kabelstecker 1F neutral+erde
24.	24CR10-2	Gulvstativ	Floor stand	Untergestell
25.	24CR10-9	Afsætningsplade for gulvstativ	Storage leaf for floor stand	Absatzplatte für Untergestell
26.	24CR10-9.3	Udtræksplade for gulvstativ	Extension leaf for floor stand	Ausziehplatte für Untergestell
27.	24CR10-18	Gummifod til gulvstativ	rubberpad for floor stand	Gummifuss für Untergestell
28.	24CR10-19	3 mm gummifod	Rubberpad 3 mm	Gummifuss 3 mm
29.	24CR10-20	6 mm gummifod	Rubberpad 6 mm	Gummifuss 6 mm
30.	STA5088	Maskinskrue 8x16mm	Screw 8x16mm	Schraube 8x16mm
31.	STA5622	cyl.skr.m.i.6kt M6X20	Screw M6x20	Schraube M6x20
32.	STA5618	Skrue M6x20	Screw M6x20	Schraube M6x20
33.	STA5818	Møtrik M8	Nut M8	Mutter M8
34.	STA5713	Cylinderskrue M4x25 mm	Screw M4x25mm	Schraube M4x25mm
35.	CR10-291	Bagplade til overdel	Back plate for top part	Hinterboden für Oberteil
36.	STA6086	Sikringskive ø8mm	Washer ø8mm	Scheibe ø8mm
37.	STA5837	Låsemøtrik M6	Locknut M6	Kontermutter M6

* Sælges kun som CR10-22.17M.....Bagplade monteret
 Sold only as CR10-22.17MBack plate mounted
 Nur verkauft wie CR10-22.17MHinterboden montiert

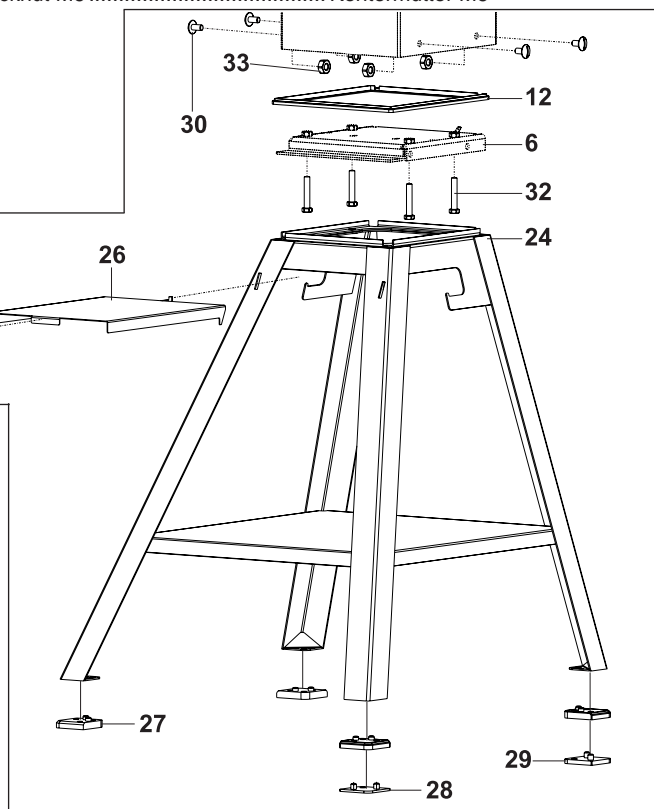
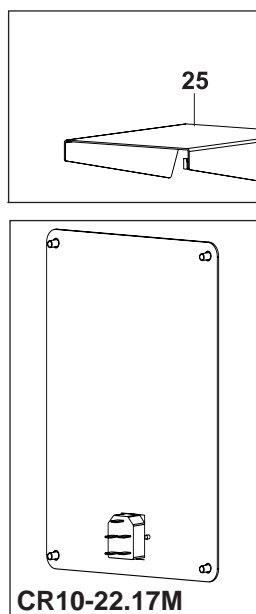
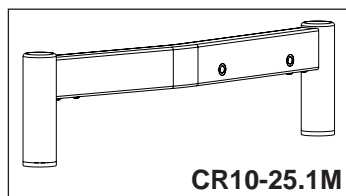
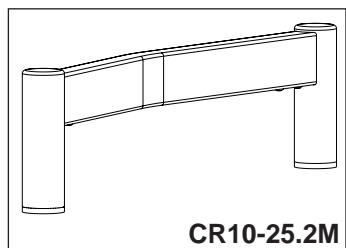

Til maskinnummer

To machine number

Biss Maschinenummer

10009165

10009165

10009165

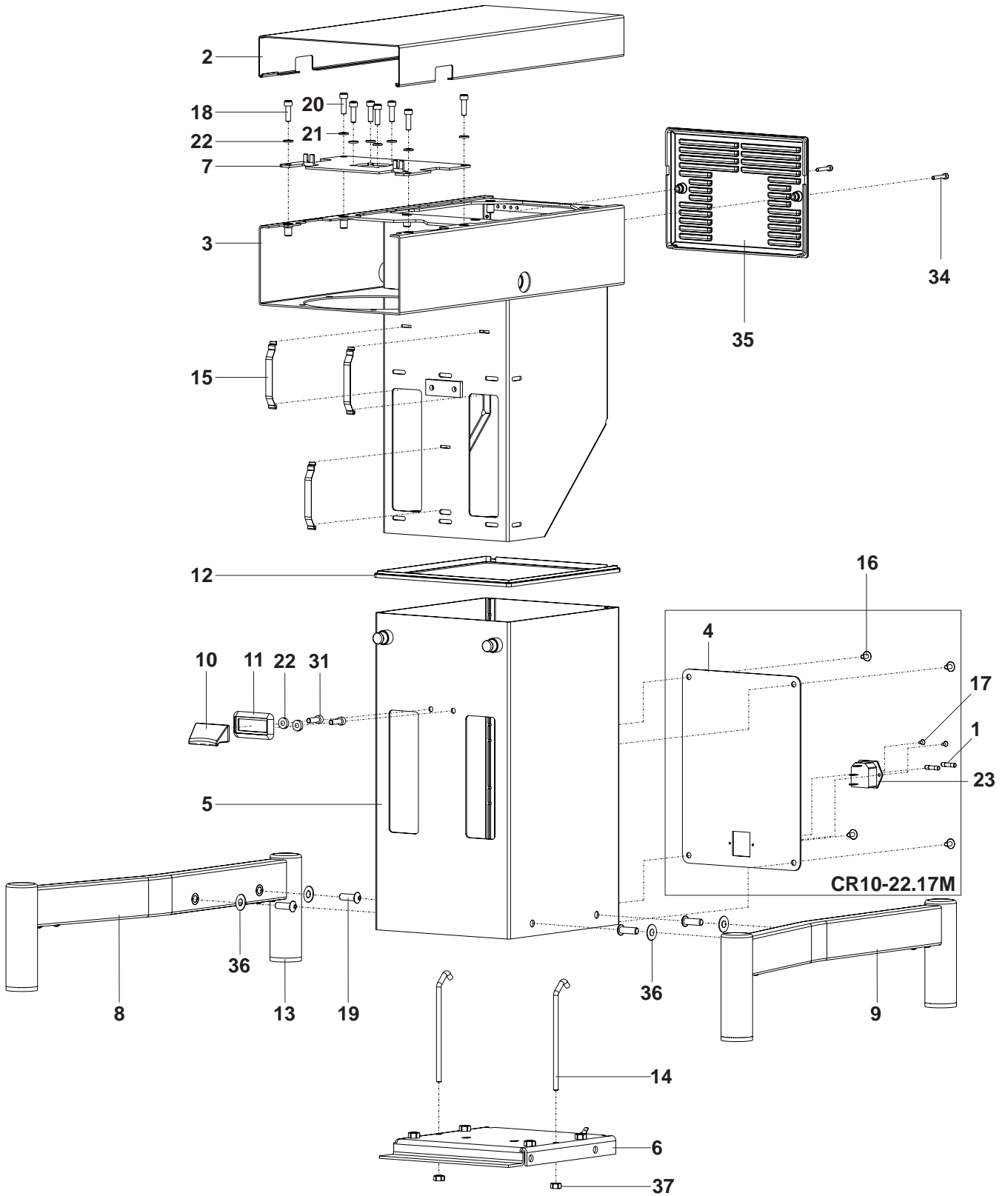

Fra maskinnummer

From machine number

Von Maschinennummer

10009166

10009166

10009166

Fig no.	Order no.	Beskrivelse	Description	Beschreibung
1.	R20E-418.9	Sikring Træg 10 Amp	fuse slow 10A	Sicherung träge 10A
2.	CR10-21.2	Låg for skærm m. magnet	topcover for guard w. magnet	Deckel f. Schirm m. Magnet
3.	CR10-22.13	Ramme	Frame	Rahmen
4.	* CR20-22.17R	Bagplade, 10Amp sikring	Back plate, 10 Amp fuse	Hinterboden, 10A Sicherung
5.	CR10-22.30	Tårn	Column	Ständer
6.	CR10-22.35	Bundplade	Base plate	bodenplatte
7.	CR10-22.77	Gear plade	Plate for gear	Getriebeplatte
8.	CR10-25.7M	Fod venstre monteret, rustfri stål	Left foot mounted, stainless steel	Fuss links montiert, Edelstahl
9.	CR10-25.6M	Fod højre monteret, rustfri stål	Right foot mounted, stainless steel	Fuss rechts montiert, Edelstahl
10.	CR10-43	Holder for kedel	holder for bowl	Kesselhalter
11.	CR10-43.1	Pakning for kedelholder	Gasket for holder for bowl	Dichtung für Kesselhalter
12.	CR10-207	Pakning for tårn	Gasket for column	Dichtung für ständer
13.	CR10-218	Gummifod	rubberpad	gummifuss
14.	CR10-302	Stag	Tie rod	Stag
15.	CR10-310	Fjeder til dæklade	retaining spring f/plate	deckplattenklemme
16.	STA5080	Maskinskruer M6x10	Screw M6x10	Schraube M6x10
17.	STA5237	Pladeskruer	selftapping screw	Schneidschraube
18.	STA5756	Skrue M6x20	Screw M6x20	Schraube M6x20
19.	STA5686	Skrue M8x25 A2	Screw M8x25 A2	Schraube M8x25 A2
20.	STA5755	Sekskantsskrue M5 x 10	Screw M5 x 10	Schraube M5 x 10
23.	STA7210	El-brønd 1F nul+jord - TIL 5L	Cable plug 1F neutral+earth	Kabelstecker 1F neutral+erde
24.	24CR10-2	Gulvstativ	Floor stand	Untergestell
25.	24CR10-9	Afsætningsplade for gulvstativ	Storage leaf for floor stand	Absatzplatte für Untergestell
26.	24CR10-9.3	Udtræksplade for gulvstativ	Extension leaf for floor stand	Ausziehplatte für Untergestell
27.	24CR10-18	Gummifod til gulvstativ	rubberpad for floor stand	Gummifuss für Untergestell
28.	24CR10-19	3 mm gummifod	Rubberpad 3 mm	Gummifuss 3 mm
29.	24CR10-20	6 mm gummifod	Rubberpad 6 mm	Gummifuss 6 mm
30.	STA5088	Maskinskruer 8x16mm	Screw 8x16mm	Schraube 8x16mm
31.	STA5622	cyl.skr.m.i.6kt M6X20	Screw M6x20	Schraube M6x20
32.	STA5618	Skrue M6x20	Screw M6x20	Schraube M6x20
33.	STA5818	Møtrik M8	Nut M8	Mutter M8
34.	STA5713	Cylinderskrue M4x25 mm	Screw M4x25mm	Schraube M4x25mm
35.	CR10-291	Bagplade til overdel	Back plate for top part	Hinterboden für Oberteil
36.	STA6086	Sikringskive ø8mm	Washer ø8mm	Scheibe ø8mm
37.	STA5837	Låsemøtrik M6	Locknut M6	Kontermutter M6

* Sælges kun som CR20-22.17RBagplade monteret
 Sold only as CR20-22.17R.....Back plate mounted
 Nur verkauft wie CR20-22.17R.....Hinterboden montiert

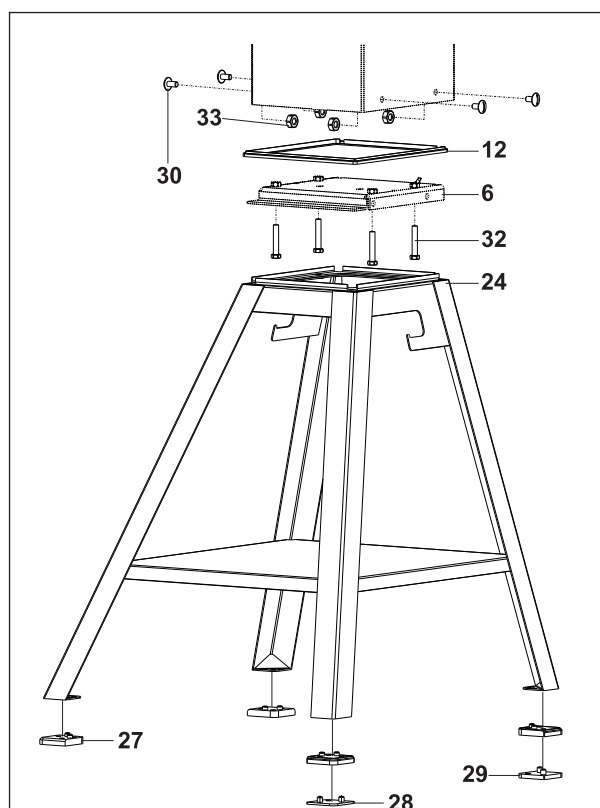
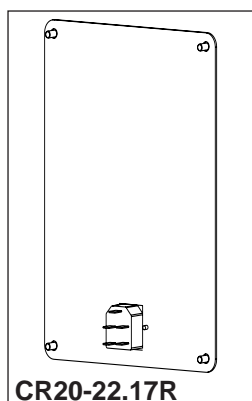
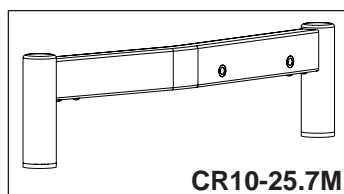
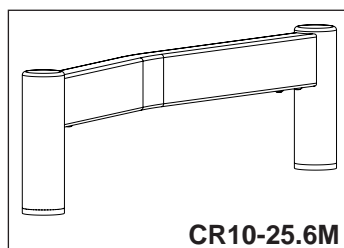

Fra maskinnummer

From machine number

Von Maschinenummer

10009166

10009166

10009166

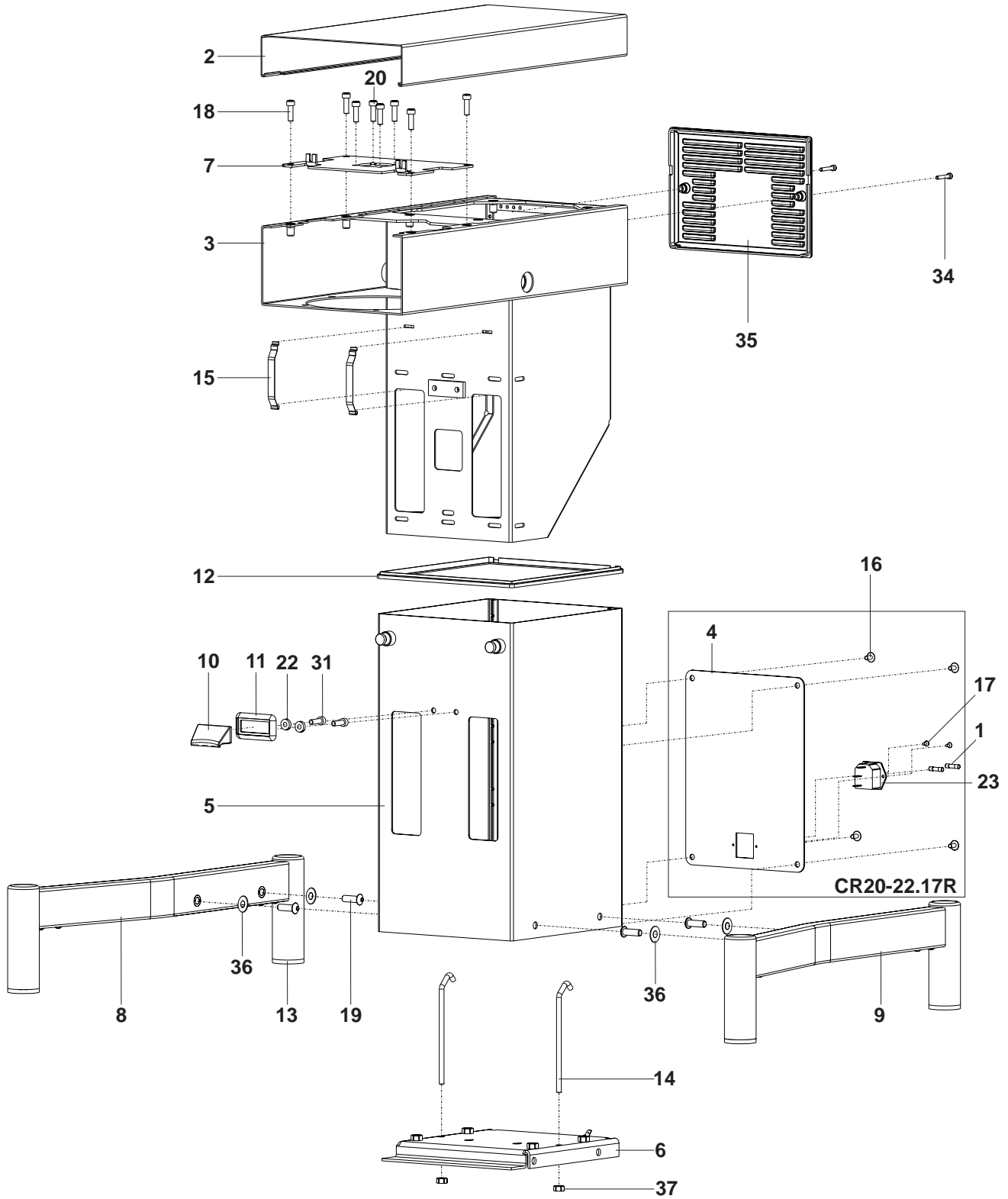

ITEM	Part number	Name	Name UK	Sælges som/ Sold as
1	56CR10P-22	10L Plastik sikkerhedsskærm	10L Plastic safety guard	
2	56CR10-109	Mikroswitch ring	Microswitch ring	
3	STA5755	Sekskantskrue m. flange/spærreribber M5x10mm	Hex ribbed flange bolt M5x10mm	
4	56CR10-110M	Switch beslag komplet	Switch bracket complete	
5	RN20-194.37M	Skærmmicro	Safety guard cabel	
6	56CR10-110	Microswitch beslag	Microswitch bracket	56CR10-110M
7	AE140-516	Magnet ø14x12	Magnet ø14x12	56CR10-110M
8	56CR10-108	Magnet holder	Magnet holder	56CR10-110M
9	STA5697	Cylinder skrue M3x16	Socket head screw M3x16	56CR10-110M
10	56CR10-30	Mikroswitch med rullearm -Tre ben PT-10524-100-1	Microswitch with rollerarm PT-10524-100-1	56CR10-110M

	14010-1003	Plastskærm komplet	Safety Guard complete	
--	------------	--------------------	-----------------------	--

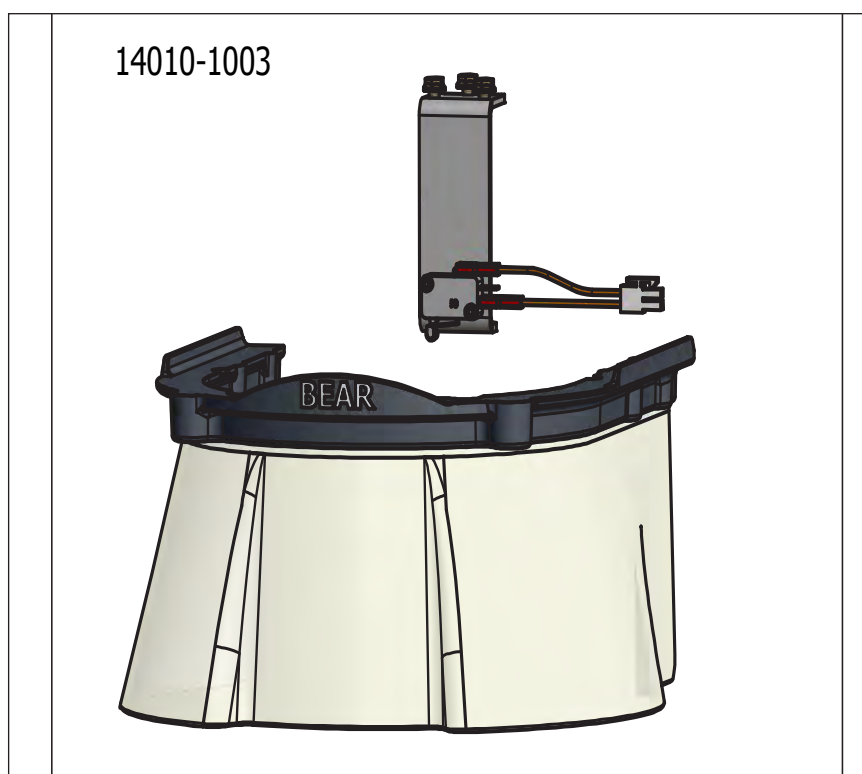

Fra maskinnummer	From machine number	Von Maschinennummer
10009148	10009148	10009148

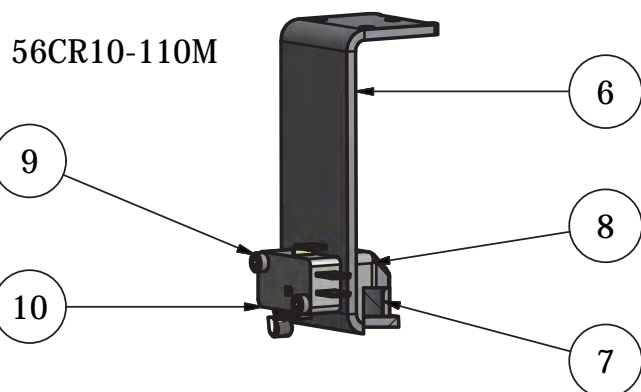
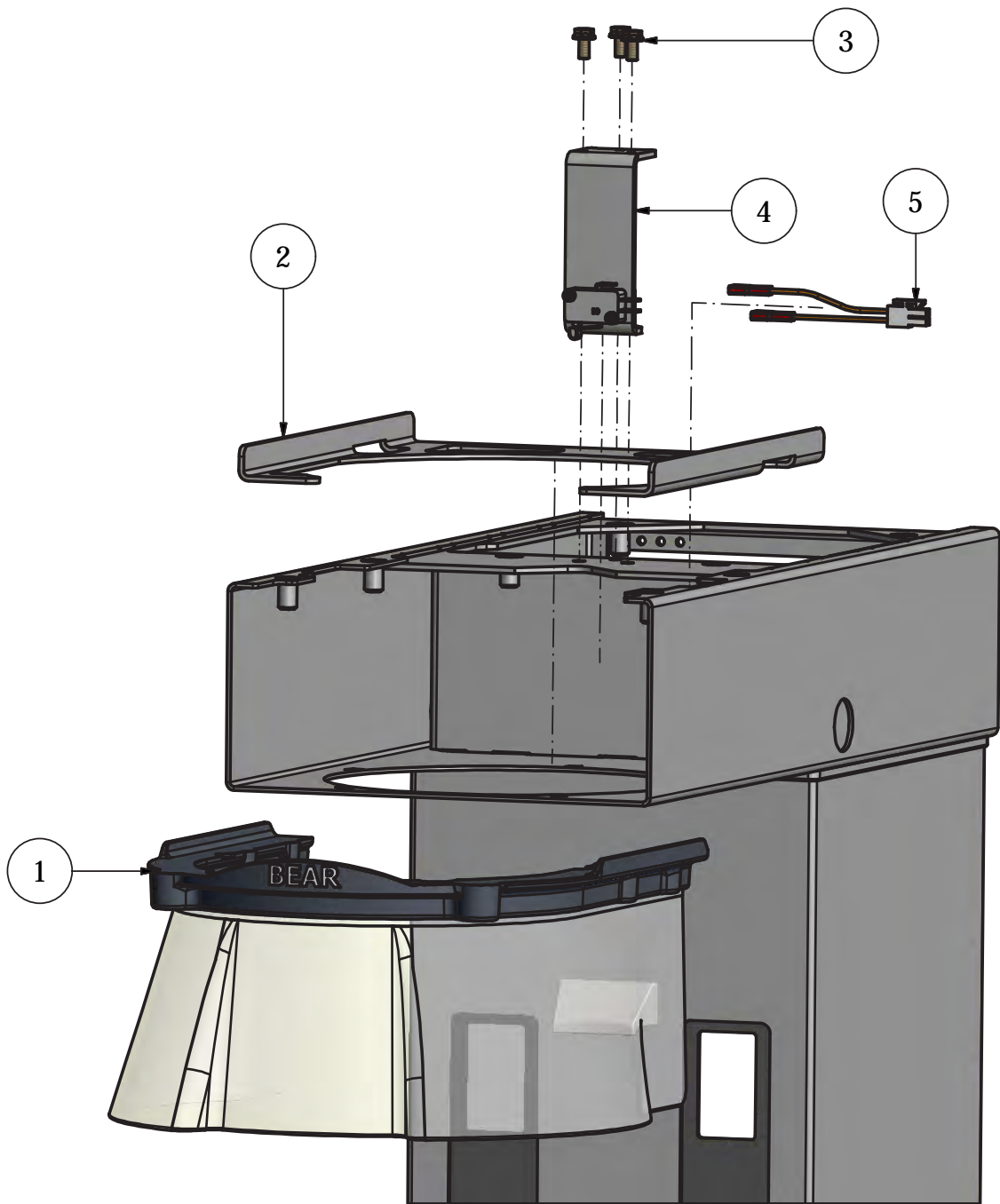
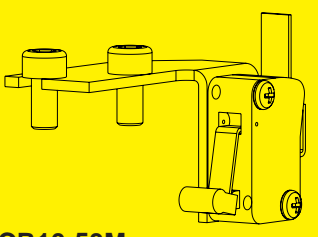

Fig no.	Order no.	Beskrivelse	Description	Beschreibung
1.	*	56SN20-30..... Microswitch	microswitch	mikroschalter
2.		CR10-131.1M Håndtag monteret med kugle	Handle.....	Handgriff
3.		CR10-23.1 Kedelbøjle, rustfri.....	bowlarm, stainless steel.....	kesselarm, rostfrei
4.		CR10-304 Dækplade	coverplate.....	Deckplatte
5.		CR10-306.1 Dæksel.....	cover	Schutzdeckel
6.		CR10-306.2 Speciel feder.....	key	Feder
7.	*	CR10-53 CE-micro beslag	fitting for CE micro switch	Beschlag für CE-Mikroschalter
8.		CR10-62 Aksel for løftehåndtag.....	shaft for lifting handle	Welle für Hubhandgriff
9.		CR10-62.12 Dækprop	plug button	deckfropfen
10.	**	CR10-63M Krumtap arm	crank with circular webs	Kurbelarm
11.	**	CR10-65M Samlingsplade med bøsninger...Join plate	Join plate	Verbindungsplatte
12.	**	CR10-68 Bøjleaksel.....	Bowl arm guide rod.....	Bügelwelle
13.	**	CR10-83 Løfteaksel.....	Lifting shaft	Hubwelle
14.		STA2005 Pasfeder A 5x5x12.....	key A 5x5x12	Feder A 5x5x12
15.		STA3401 Seegerring ø8x0,8mm, DIN471	circlip ø8x0,8mm, DIN471	Seegering ø8x0,8mm, DIN471
16.		STA3413 Seegerring ø18x1,2mm, DIN471 ...	circlip ø18x1,2mm, DIN471	Seegering ø18x1,2mm, DIN471
17.		STA3504 Låsering for aksel ø15 DIN6799	lock ring for shaft ø15 DIN6799	Schließring für Welle ø15 DIN6799
18.		STA3581 Sikringsring ø12, type 863.....	circlip ø12, type 863	Seegering ø12, type 863
19.		STA5251 pladeskrue 2.9x16.0 din 7981.....	Screw 2.9x16.0 din 7981.....	Schraube 2.9x16.0 din 7981
20.		STA5317 Sætskrue, syrefast M5X10	screw, acid-proof M5X10.....	Schraube, säurefest M5X10
21.		STA5721 Skrue M5x30 DIN912	Screw M5x30 DIN912	Schraube M5x30 DIN912
22.		STA6001 Nylonskive ø17x8.4x1.6mm.....	nylon washer ø17x8.4x1.6mm	nylonscheibe ø17x8.4x1.6mm
23.		STA6091 Tallerkenfjeder ø35,5x18,3x0,9.....	Disk spring ø35,5x18,3x0,9.....	Scheibefeder ø35,5x18,3x0,9
24.		STA6205 Fjedersplit E 2.5mm.....	cutterpin E 2.5mm	federsplint E 2.5mm

* Sælges kun som CR10-53M.....Microbeslag monteret
 Sold only as CR10-53Mfitting for microswitch, mounted
 Nur verkauft wie CR10-53MBeschlag für Mikroschalter, montiert

** Sælges kun som CR10-68M.....Kedelløft monteret
 Sold only as CR10-68MBowl lift mounted
 Nur verkauft wie CR10-68MKesselanheben montiert

Fra maskinnummer	Se side 9, kedeldetektering
From machine number	See page 9, bowl detection
Von Maschinenummer	Siehe Seite 9, Kesselfühler
10010182	

Til maskinnummer	
To machine number	
Biss Maschinenummer	
10010181	

CR10-53M

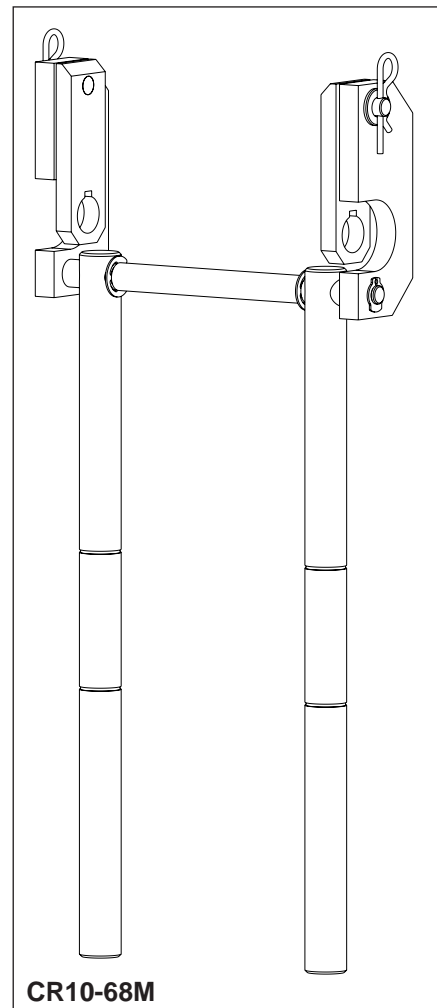

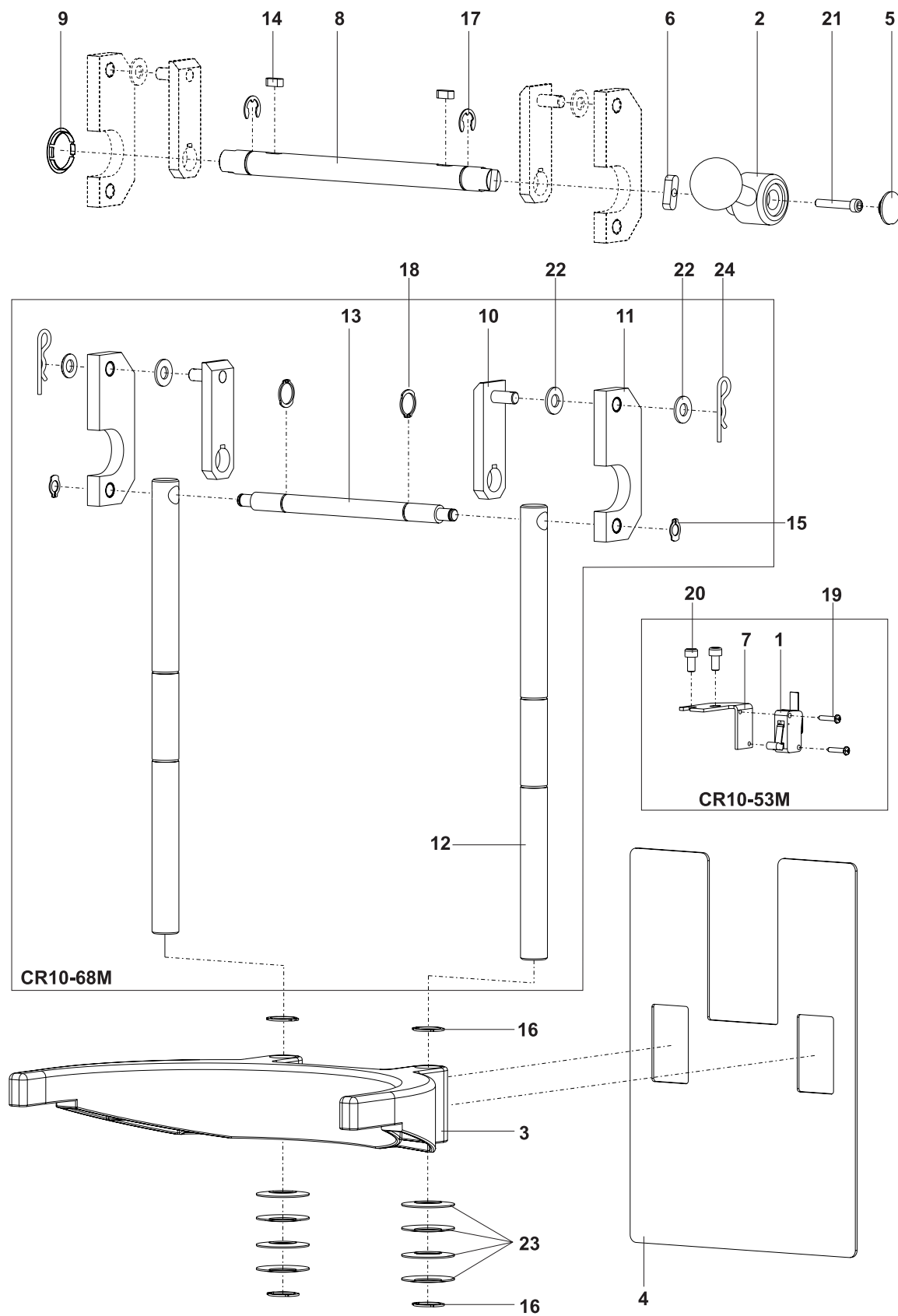
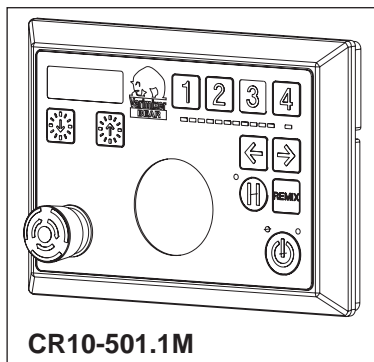
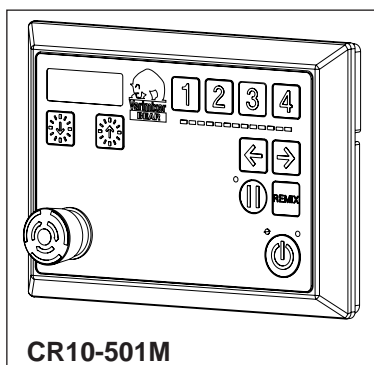
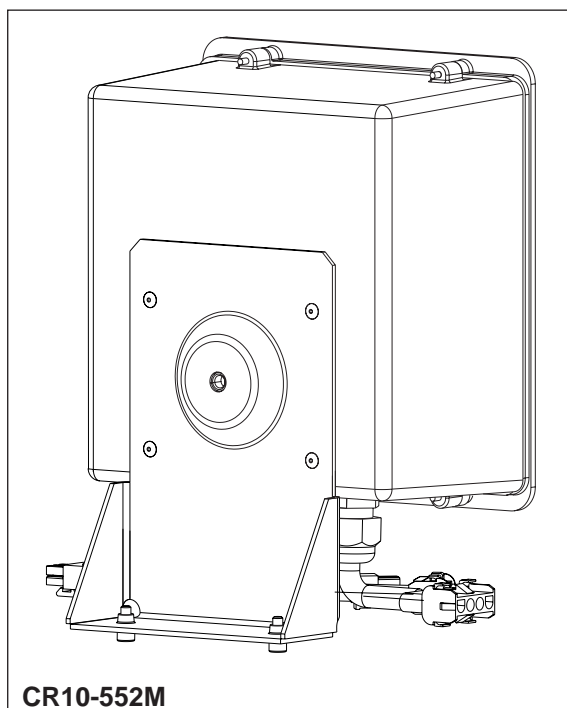

Fig no.	Order no.	Beskrivelse	Description	Beschreibung
1.	* CR10-149.5	Frontfolie	Front foil	Frontfolie
2.	* CR10-149.7	Frontfolie, hjælpetræk	Front foil, attachment drive	Frontfolie, Anschlussgetriebe
3.	CR10-174.11	Nødstop	emergency stop compl.	notstopp kompl.
4.	** CR10-430/430.1	Trafo CR10 380-440 V / 110-120V	Trafo CR10 380-440 V / 110-120V	Trafo CR10 380-440 V / 110-120V
5.	* CR10-501	Display print VL2 CR10	Display print VL2 CR10	Leiterplatte Darstellung VL2 CR10
6.	* CR10-553	Dækkasse, display print VL2	cover box, display print VL2	Deckkasten, Leiterplatte Darstellung VL2
7.	CR10-558M	Dækkasse monteret med beslag	cover box with fitting	Deckkasten mit Halter
8.	CR10-601	Frekvensomformer CR10	frequency converter	Frequenzumformer
9.	* CR10-650.20	Frontpanel	front panel	Fronttafel
10.	CR10-650.21	Bredt mont.beslag til frontpanel	Broad mounting fittings, front panel	Breiter Mont.beschlag, Fronttafel
11.	CR10-650.22	Smallt mont.beslag til frontpanel	Narros mounting fittings, front panel	Schmaler Mont.beschlag, Fronttafel
12.	RN20-551	Pakning for dækkasse	Gasket for cover box	Dictung für Deckkasten
13.	STA5232	Skruer M4x8	Screw M4x8	Schraube M4x8
14.	STA5253	Selvkærende skrue M3,5x25	Screw M3,5x25	Schraube M3,5x25
15.	STA5726	Cylinderskrue, M4X10	screw, M4X10	Schraube, M4X10
16.	STA5713	Skruer M4x25	Screw M4x25	Schraube M4x25
17.	STA5714	Skruer M4x30	Screw M4x30	Schraube M4x30
18.	STA5717	Skruer M4x45	Screw M4x45	Schraube M4x45
19.	STA5805	Kontramøtrik M4	Nut M4	Mutter M4
	CR10-556.2	Køleprofil	cooling profile	Wärmeableiter

CR10-552.2M ..Frekvensomformer monteret..... frequency converter mounted Frequenzumformer montiert

* Sælges kun som CR10-501M / CR10-501.1M Frontpanel, ikke hjælpetræk / Frontpanel, hjælpetræk
 Sold only as CR10-501M / CR10-501.1M..... Front panel, no attachment drive / Front panel, attachment drive
 Nur verkauft wie CR10-501M / CR10-501.1M..... Fronttafel, kein Anschlussgetriebe / Fronttafel, Anschlussgetriebe

** Kun ved 380-440 V / 110-120V.....only for 380-440 V / 110-120VNur für 380-440 V / 110-120V



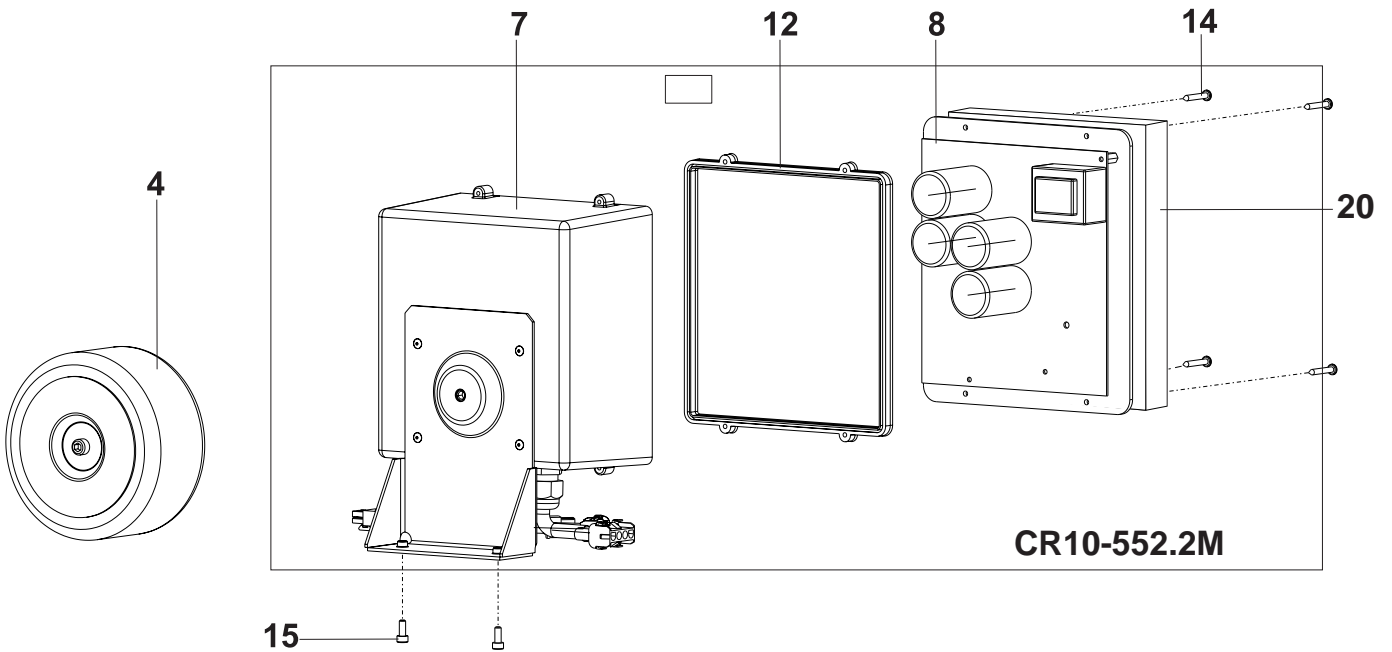
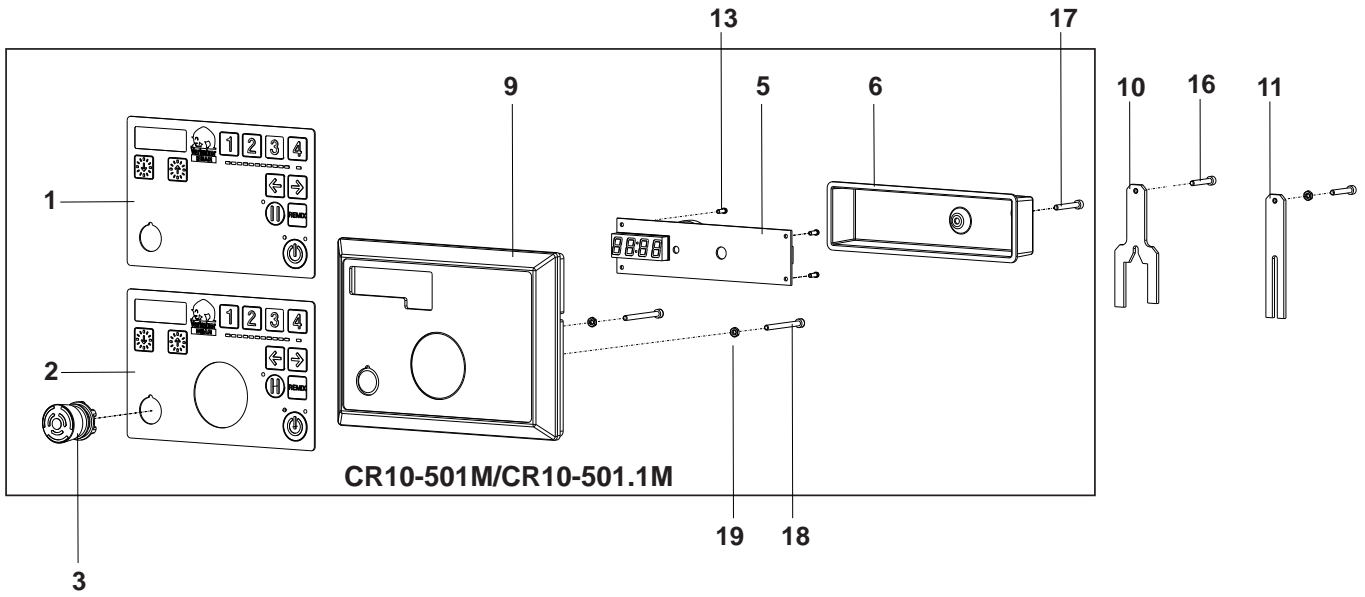
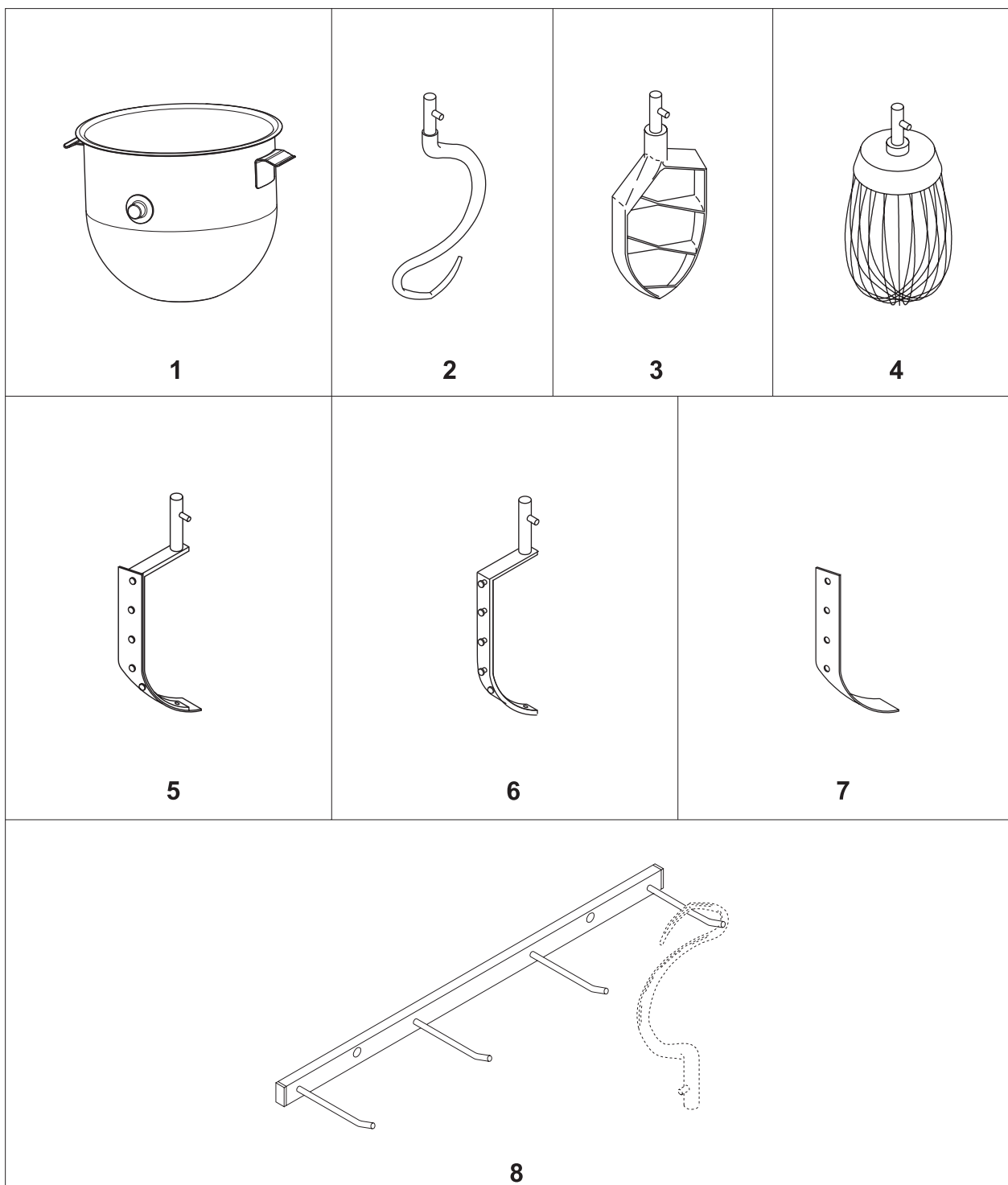
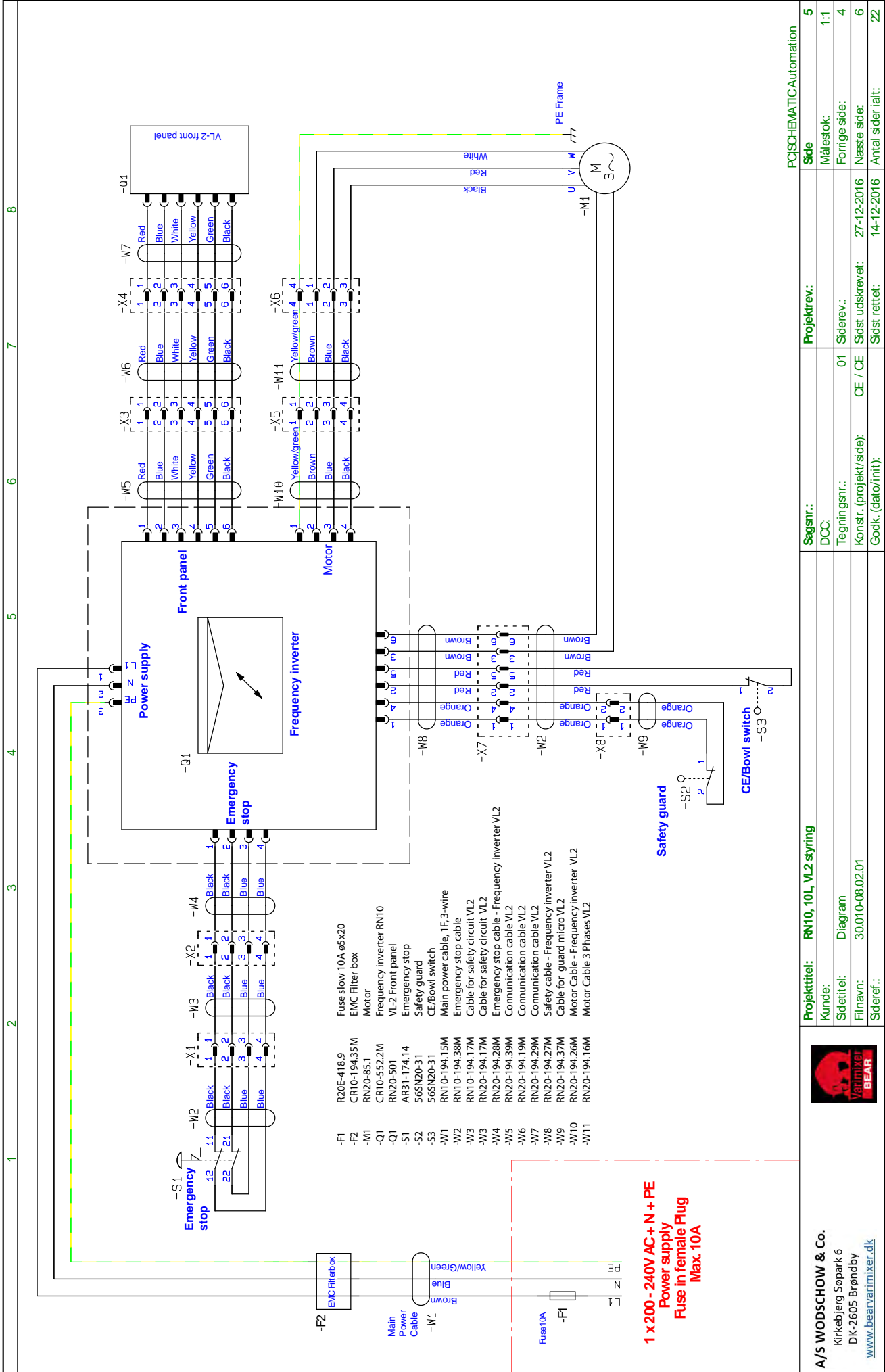

Fig no.	Order no.	Beskrivelse	Description	Beschreibung
1.	01078-.....	10L Kedel rustfri.....	10L bowl stainless steel	10L Kessel, rostfrei Stahl
2.	CR10-78M.....	10L Krog rustfri	10L hook, stainless steel	10L Knetter, rostfrei Stahl
3.	CR10-27M.....	10L Spatel rustfri	10L flat beater stainless steel	10L Rührer, rostfrei Stahl
4.	CR10-28M.....	10L ris Standard rustfri	10L whip stainless steel	10L Besen, rostfrei Stahl
5.	42CR10-202.....	10L Skraber rustfri med nylonblad.....	10L scraper s.s. with nylon blade.....	10L Abstreifer rostfr. St. mit Nylonschiene
6.	CR10-200.....	10L skraber rustfri.....	10L scraper , stainless steel	10L Abstreifer, rostfrei Stahl
7.	42CR10-204.....	10L skraberblad nylon	10L scraper blade, nylon.....	10L Abstreiferschiene, Nylon
8.	48R20Z	Ophæng for røreværktøj.....	Rack for mixing tools	Leiste für Rührwerkzeuge





Projekttitel:	RN10, 10L, VL2 styring
Kunde:	
Sidettitel:	Diagram
Filnavn:	30.010-08.02.01
Sideref.:	



A/S WODSCHOW & Co.
Kirkebjerg Søpark 6
DK-2605 Brøndby
www.beatvarimixer.dk

Sagsnr.:	
DOC:	
Tegningsnr.:	01
Konstr. (projekt/side):	CE / CE
Godk. (dato/init):	

Projektrev.:	
Sideretv.:	
Såst udskevet:	27-12-2016
Såst rettet:	14-12-2016
Antal sider ialt:	22

Sagsnr.:	
Projekttitel:	PCSCH-EMATICAutomation
Side:	
Målestok:	1:1
Førrige side:	
Næste side:	